

Registry of Ex Military Land Rovers

Copyright of this document is retained by the original authors. Some parts may have been superseded or changed since that time.

This document has been download from the Registry of Ex Military Land Rovers at <http://www.remlr.com> . All files available from this site are free of charge.

If you have paid for this document please report where you purchased it from to the Registry of Ex Military Land Rovers Inc at webmaster@remlr.com



7610-66-128-4353



AUSTRALIAN ARMY

TECHNICAL MANUAL

USER HANDBOOK

TRUCK, CARGO, LIGHT, MC2

2320-66-128-4226
(LIABILITY CODE No. 74800/01)
Specification Army (Aust) 6432
Headquarters Logistic Command
1989

(D.M.M. Francis)
Major General
Assistant Chief of the
General Staff
Materiel — Army

Issued by Command
of the Chief of the
General Staff

AMENDMENT RECORD

Amendment No.	Actioned by: Signature and Date

SYNOPSIS

The Truck, Cargo, Light, MC2 is a six wheeled Army vehicle designed specifically for military use. The vehicle is based on the Land Rover 110 Series commercial, but with an extended chassis and an additional axle. The truck, cargo is a constant four wheel drive, with selective six wheel drive for negotiating difficult terrain. Vehicle slinging, tie-down and recovery points are incorporated in the chassis.

The cab can accommodate up to three persons while the rear tray can accommodate up to twelve persons or 2 tonne of cargo.

The vehicle has a range of approximately 600 km on first class roads. The rated gross vehicle mass (GVM) and gross combined mass (GCM) for both highway and cross country conditions is 5.6 tonne and 7.1 tonne respectively.

WARNING

Page No.

WARNING

55

Should the engine become overheated, park the vehicle in a safe working area and allow the engine to cool before attempting repairs to, or refilling of, the cooling system.

WARNING

57

Because of the excellent rough terrain characteristics of this vehicle, drivers are cautioned to maintain a safe speed for the conditions encountered **especially when towing a trailer or utilizing tyre chains.**

WARNING

58

The parking brake acts on the transmission, not the rear wheels. The differential lock must be engaged and the wheels chocked to enable the vehicle to be raised safely.

WARNING

66

Ensure that the bonnet support stay is properly locked before releasing the bonnet.

WARNING

—

This vehicle is painted in polyurethane paint. Precautions should be taken prior to carrying out repairs which include painting, sanding, scraping or welding. For safety precautions refer to Introduction Into Service Instruction, Materiel management Policy Statement, Painting Policy for Vehicles and Equipment or relevant EMEI.

LIST OF CONTENTS

Preliminary Pages			Page No.
Synopsis			iii
Warnings.....			iv
List of contents.....			v
List of illustrations			vi
List of tables			viii
Associated publications			ix
Frontispiece.....			x
Maintenance Supply Item (MSI) identification.....			xi
Chapter	Section	Heading	Page No.
1		General description.....	1
	1	Data summary.....	2
	2	Shipping and transportation data.....	11
	3	Equipment description	14
2		Operating instructions.....	37
	1	Warranty and repair.....	38
	2	Vehicle operation	53
3		Operator servicing.....	63
	1	Servicing.....	64
	2	Lubrication	78
Complete Equipment Schedule (CES).....			88
Index			95

LIST OF ILLUSTRATIONS

Fig. No.	Title	Page No.
1-1	Truck, Cargo, Light, MC2 — front view	x
1-2	Truck, Cargo, Light, MC2 — rear view	x
1-3	Slings and tie-down points	13
1-4	Air temperature and distribution controls	17
1-5	Combination switch operation	19
1-6	Warning lights	21
1-7	Windscreen washer and wiper control	22
1-8	Hazard warning and cab dome light switches	23
1-9	Bonnet safety catch	24
1-10	Main lighting switch	24
1-11	Gear change pattern	25
1-12	Transfer case shift pattern	26
1-13	Fuses	26
1-14	Seat adjustment	27
1-15	Rear window	28
1-16	Roof hatch	28
1-17	Rear side window	29
1-18	Spare wheel lowering	30
1-19	Vehicle nomenclature plate	31
1-20	Servicing data and tyre pressure plate	31
1-21	Shipping data plate	32
1-22	Towing and dyno test data plate	32
1-23	Jacking procedure plate	33
1-24	Instruments, electrical accessories and controls	35
2-1	Starter switch positions	54
2-2	Flywheel housing drain	56
2-3	Jack position — front wheels	59
2-4	Jack position — rear wheels	59
2-5	Canopy bow dummy socket	61
2-6	Canopy retaining straps	61
2-7	Rear seat stowage	62
3-1	Thermostat housing	67
3-2	Bleeding the fuel system	68
3-3	Lubrication and oil drain/refill points	79
3-4	Engine right hand side	79
3-5	Oil filter removal	80
3-6	Transmission drain and fill plugs	81
3-7	Transfer case drain and fill plugs	81
3-8	Intermediate axle drain and fill plugs	82
3-9	Rear axle drain and fill plugs	82

Fig. No.	Title	Page No.
3-10	Swivel pin housing drain and fill plugs	83
3-11	Fuel filter	84
3-12	Fuel sedimenter.....	84
3-13	Air cleaner removal	85
3-14	Air cleaner elements	85
3-15	Brake reservoir	86
3-16	Clutch reservoir	87

LIST OF TABLES

Table No.	Title	Page No.
1-1	Location of identification numbers on MSI's	xi
2-1	Pro-rata warranty	38
2-2	JRA State offices	41
2-3	Land Rover dealers	41
3-1	Daily tasks	69
3-2	Fortnightly tasks.....	70
3-3	Initial servicing.....	71
3-4	Minor servicing.....	72
3-5	Major servicing.....	74
3-6	List of lubricants.....	78

ASSOCIATED PUBLICATIONS

1. Standing Orders for Vehicle Operation and Servicing
2. Australian Army Books:
TGM 120 Record Book for Service Equipment — Army
3. Complete Equipment Schedules (CES):
(a) SCES 12044 } Truck, Cargo, Light, MC2
(b) Equipment Kit SCES 12045 }
4. Block Scale 2406/31 Issue 1 — Special Tools for RAEME – B Vehicles – Truck, Cargo, Light, MC2 (Land Rover Model 110)
5. EMEI VEH A029 — Servicing of B Vehicles
6. EMEI VEH A119-22 — Repair of Vehicles Under Warranty Agreement — Policy Instruction
7. EMEI VEH G 200 — Data Summary (Truck, Cargo, Light)
8. EMEI VEH G 202 — Technical Description (Truck, Cargo, Light)
9. EMEI VEH G 203 — Unit Repair (Truck, Cargo, Light)
10. EMEI VEH G 204 — Field Repair (Truck, Cargo, Light)
11. EMEI VEH G 204-1 — Base Repair (Truck, Cargo, Light)
12. EMEI VEH G 209 — Servicing Instruction
13. Australian Change in War Materiel 31178
14. Repair Parts Scale 02185

FRONTISPIECE

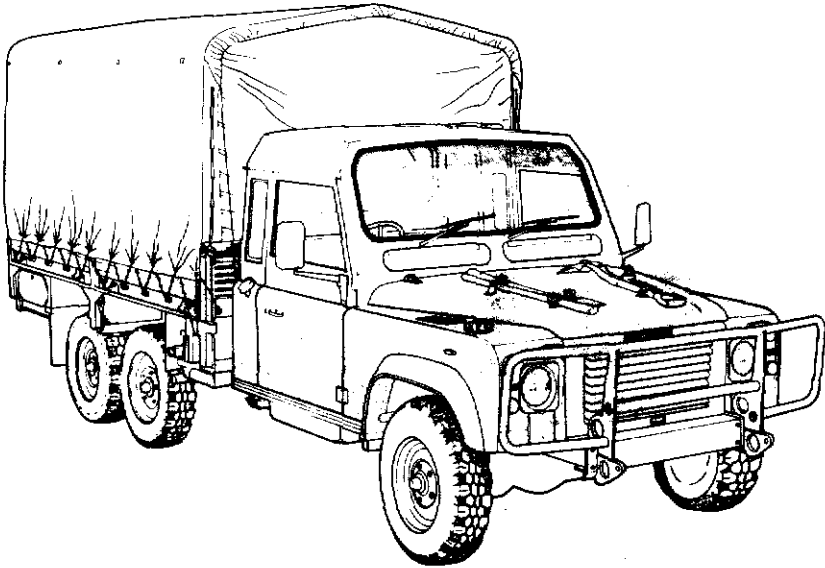

Figure 1-1 Truck, Cargo, Light, MC2 — front view

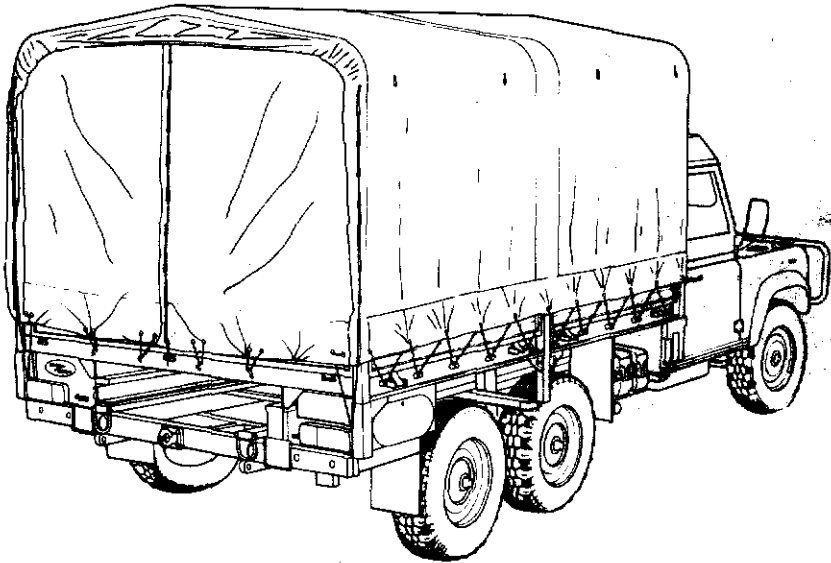

Figure 1-2 Truck, Cargo, Light, MC2 — rear view

MAINTENANCE SUPPLY ITEM (MSI) IDENTIFICATION

Table 1-1 Location of identification numbers on MSI's

Chassis No. — Right hand side of the chassis, forward of the spring mounting turret

Chassis nameplate — Left hand seat box, in the cab

Engine No. — Left hand side of the engine block

Injection pump identification — Side of the pump

Transmission and transfer case — Rear of the transfer case



CHAPTER 1

GENERAL DESCRIPTION

SECTION 1 — DATA SUMMARY

**SECTION 2 — SHIPPING AND
TRANSPORTATION
DATA**

**SECTION 3 — EQUIPMENT
DESCRIPTION**

SECTION 1

DATA SUMMARY

NOTE

Throughout this manual all references to left hand (LH) and right hand (RH) are as viewed from the rear of the vehicle looking forward.

Truck Model No.	Truck Light 6 x 6 MC2
1. Engine	
Manufacturer	Isuzu
Type	4BD1 TRB-G series, turbocharged, four cylinder in line, overhead valve four cycle direct injection diesel engine
Displacement	3.856 litres
Bore	102 mm
Stroke	118 mm
Compression ratio	17:1
Firing order	1 - 3 - 4 - 2
Power	90 kW @ 3000 rpm and 314 Nm @ 2200 rpm
No load maximum	3600 ± 100
Engine idle speed	650 ± 20 rpm
Oil capacity	8.5 litre including filters
Oil filters	External, full flow, spin on
Oil pressure	390-581 kPa @ 2400 rpm
Oil cooler	Water cooled, plate and tube type

Engine dry weight	
— With 24 volt alternator	350 kg
— Without 24 volt system	322.5 kg
Turbocharger	Water cooled, Garret, model ATD-T25

2. Cooling system

Type	Pressurised spill return system with thermostat control, pump and fan assisted
Capacity	12.8 litres
Thermostat	Downward opening wax element type incorporating a by-pass shut off valve. Opening temperature 82°C
Coolant	Water with 5% Alfloc 2001 inhibitor

3. Engine accessory drive

Type	Single V-belt
Tension	Approximately 10-15 mm deflection, midway along the longest span using moderate thumb force

4. Fuel system

Fuel pump	Diesel Kiki (Bosch) in-line Type A model 550k with automatic timer
Governor	RLD-K mechanical
Transfer pump	KE mechanical with gauze intake filter
Injectors	Four-hole spray type
Main filter	Inlet manifold mounted, spin-on type
Sedimenter	Two chassis mounted CAV SS type sedimenters are connected in series with fuel systems that are in parallel
Fuel tanks	Two, 62 litre tanks connected in parallel and independent of each other, tank selection by dash mounted switch

5. Engine starter

Manufacturer Mitsubishi
Type Waterproof, gear reduction

6. Clutch

Manufacturer Repco/Isuzu
Type Hydraulically operated single dry plate and diaphragm spring
Free travel (pedal) 6 mm minimum

7. Transmission

Manufacturer Land Rover
Type Model LT95A, four forward, one reverse, synchromesh on all forward gears. Incorporates an integral transfer case
Ratios
First gear 4.069:1
Second gear 2.448:1
Third gear 1.505:1
Fourth gear 1.000:1
Reverse gear 3.664:1

8. Transfer case

Manufacturer Land Rover
Type High and low gear ratios operating on the main transmission output. The front and intermediate axles are permanently engaged via a differential in the transfer case. The rear axle is automatically engaged when the transfer case differential is locked — for traversing difficult terrain
Ratios
High range 0.996:1
Low-range 3.321:1

9. Front axle

Manufacturer	Land Rover
Type	Fully floating spiral bevel steerable drive axle with enclosed outboard constant velocity joints and four pinion differential
Ratio	4.7:1
Track	1698 mm
Load rating	1650 kg

10. Rear axles

Manufacturer	GKN
Type	Salisbury fully floating hypoid bevel drive, four pinion differential
Ratio	4.7:1
Track	1698 mm
Load rating	2050 kg

11. Propeller shafts

Type	
—Front	An open shaft, incorporating a Hookes type universal joint at either end. Variations in the length of the shaft is achieved by employing a splined sliding joint between the two universal joints
—Intermediate	An open shaft, incorporating a Hookes type universal joint at either end. Variations in the length of the shaft is achieved by employing a splined sliding joint between the two universal joints
—Rear	A two piece open shaft incorporating a Hookes type universal joint at either

end. The centre section of the shaft is mounted via a bearing to the chassis frame and the articulation of the rear section of the shaft is achieved through the use of a double Hookes joint, and a splined sliding joint

12. Front suspension

Type	Radius arms with Panhard rod located live axle with vertically mounted double acting telescopic shock absorbers mounted inside single rate coil springs
Load rating	1650 kg

13. Rear suspension

Type	Consists of two live axles located by four semi-elliptic springs. These springs are so mounted that the ends, between the axles overlap each other and are articulated by a load sharing rocker beam connected to the chassis. Axle bump and rebound travel is controlled by chassis mounted pads and cables. Suspension dampening is by four hydraulic shock absorbers
Load rating	4100 kg

14. Steering

Manufacturer	Adwest
Type	Power assisted variable ratio worm and roller type utilizing a gear driven pump, mounted on the engine and a remote hydraulic reservoir
Turning circle	
Between kerbs	16.8 metres (nominal)
Between walls	17.2 metres (nominal)

15. Brakes

Type	Hydraulic split system with front disc and rear drum brakes, foot pedal actuated
Parking brake	Cable operated, transmission mounted drum brake
Warning devices	Dash mounted globes indicating front brake pad depth (actuated at 3 mm thickness), a failed hydraulic circuit, and parking brake applied

16. Chassis

Type	Hot dipped galvanized welded box section steel with welded box section crossmembers
Wheelbase	
Front to intermediate axle	3040 mm
Front to rear axle	3940 mm

17. Wheels and tyres

Rim type and size	Ventilated disc, 6F x 16
Tyre size	750-R-16LT 10 ply Olympic Steeltrek with 105 pattern
Tyre pressure (cold)	Highway: front 250 kPa (36 psi) intermediate 350 kPa (50 psi) rear 350 kPa (50 psi) Cross-country: front 200 kPa (29 psi) intermediate 275 kPa (40 psi) rear 275 kPa (40 psi) Sand: front 150 kPa (22 psi) intermediate 225 kPa (33 psi) rear: 225 kPa (33 psi)

Range of operation	600 km (first class roads) approx. 480 km (second class roads) approx.
Fuel consumption	22 litres per 100 km (highway laden) 27 litres per 100 km (second class laden) Fuel tank capacity 62 litres each

24. Troop carrying capacity

Fully kitted	15 including driver
--------------	---------------------

25. Tray body load area

Width — Floor level	2060 mm
— Between seats	1055 mm
Length — Floor level	3180 mm

SECTION 2

SHIPPING AND TRANSPORTATION DATA

26. Dimensions

Overall length	6001 mm
Wheelbase	3040 mm
Overall width — Over mirrors	2430 mm
— Reduced	2072 mm
Overall height — Laden	2480 mm
Canopy (Fitted) — Unladen	2550 mm
Cut down height — Laden	2050 mm
— Unladen	2080 mm
Track — Front	1698 mm
— Rear	1698 mm
Cargo tray	
Length — Internal (above seats)	3085 mm
Width — Internal	2082 mm
Height of body sides (from tray)	330 mm
Height of cargo tray from ground	
— Laden	960 mm
— Unladen	1030 mm
Rear axle to rear of vehicle overhang	1183 mm
Towing pintle height — Laden	640 mm
— Unladen	710 mm
Mass (Unladen)	
— Front	1600 kg
— Intermediate	975 kg
— Rear	975 kg
— Total	3550 kg

27. Capacities

Equipment	DEF (AUST) 206	METRIC (litres)
Engine system (including filters)	OMD-115	8.5
Cooling system (including inhibitor)		12.8
Transmission	OMD-115	2.7
Transfer case	Castrol FMX	3.2
Front axle	OEP-220	1.7
Intermediate axle	OEP-220	2.3
Rear axle	OEP-220	2.6
Swivel pin housing (each)	OEP-220	0.35
Steering box (including reservoir)	OX 46	1.25
Fuel tank — Right hand		62
— Left hand		62

NOTE

See EMEI G 209 for list of approved lubricants.

28. Fording depth

Unprepared vehicle	500 mm
Limiting features (over 500 mm)	Cooling fan
Prepared vehicle	No facility available, as for unprepared vehicle

29. Bridge classification

Solo unladen 6

30. Ground clearance

Unladen	215 mm
Limiting feature	Rear differential housings

31. Transportability

Railway loading gauges (Local authorities must be consulted)

Rail authority	Gauge	Maximum rolling stock height
Commonwealth	1435 mm	2532 mm
Commonwealth	1067 mm	2532 mm
New South Wales	1435 mm	2182 mm
Queensland	1067 mm	1806 mm
South Australia	1600 mm	2075 mm
South Australia	1435 mm	2075 mm
South Australia	1067 mm	1761 mm
Tasmania	1067 mm	1992 mm
Victoria	1600 mm	2182 mm
Victoria	1435 mm	2182 mm
Western Australia	1435 mm	2532 mm
Western Australia	1067 mm	1973 mm

32. Slinging and tie-down points are illustrated in Fig 1-3.

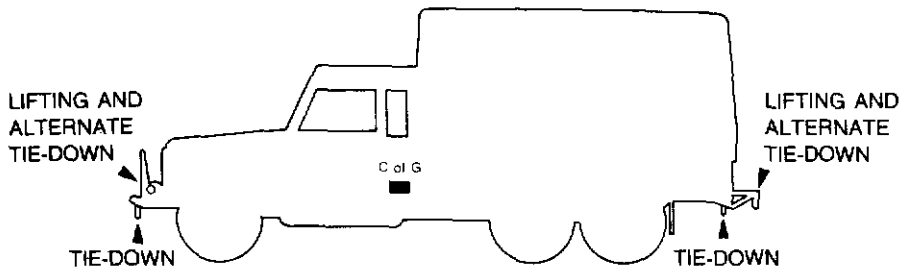

Figure 1-3 Slinging and tie-down points

33. Approach and departure angles

Approach angle	— Unladen	45 degrees
	— Laden	41 degrees
	— Limiting feature	Tie down points
Departure angle	— Unladen	33 degrees
	— Laden	30 degrees
	— Limiting feature	Tie down points
Ramp breakover angle	— Unladen	148 degrees
	— Laden	152 degrees
	— Limiting feature	Chassis rail

SECTION 3 EQUIPMENT DESCRIPTION

Introduction

34. The truck, cargo, light, MC2 has been designed specifically for military use and to meet operational requirements. To meet this requirement, the vehicle has been fitted with permanent four wheel drive, and, selective six wheel drive for negotiating difficult terrain. The transmission has eight forward gear ratios and two reverses which is coupled through a disc clutch to a 3.9 litre, turbo-charged, diesel engine.

Operational and logistic concept

35. This vehicle provides general wheeled support for first line tasks. The vehicle is fitted with a removable canopy and can be utilized to transport up to two tonne of stores or fifteen fully-kitted troops, including the driver.

Engine

36. The vehicle is fitted with an Isuzu 3.9 litre 4BD1TRB-G turbo-charged, four cylinder diesel engine which produces 90 kW at 3000 rpm and 314 Nm of torque at 2200 rpm.

Transmission

37. The transmission is a heavy duty four-speed all-synchromesh transmission with an integral two-speed transfer case. Clutch and gear operations are manual, without power assistance.

Transfer case

38. The transfer case, which is cast as part of the main transmission, provides high and low gear ratios, and four or six wheel drive capabilities. It has an integral differential fitted to prevent wind up in the drive lines during normal on road conditions and which can be locked to provide a positive drive between the front and rear axles. During off road use, the locking of this differential, by operating a dash mounted switch, automatically engages the vehicle in six wheel drive. It is imperative that this differential is locked, when crossing difficult terrain, or when conditions may lead to a loss of traction. A

high speed range and a low speed range in the transfer case can be selected by operating a floor mounted lever. The selection of a speed range will not influence the four or six wheel drive mode.

Steerable front drive axle

39. The vehicle is fitted with a steerable front drive axle, comprising of a differential carrier assembly and axles, driving through constant velocity joints to steerable drive ends fitted with hydraulically operated disc brakes.

Front suspension

40. The front suspension utilizes radius arms, a Panhard rod, vertically mounted double acting telescopic shock absorbers and single rate coil springs. Bump stops are provided to limit the upward travel of the suspension, while the shock absorbers limit the downward travel of the axle.

Rear axles

41. The rear axles are Salisbury type, fully floating hypoid bevel drive axles with offset four pinion differentials.

Rear suspension

42. Dual rate semi-elliptic leaf springs linked via shackles to a rubber bushed load sharing rocker beam. Axle movement is controlled by four long travel telescopic shock absorbers and steel cable rebound straps.

Service brakes

43. The vehicle is fitted with a dual circuit hydraulic brake system consisting of two completely separate circuits. The primary circuit supplies the rear drum brakes and the secondary circuit supplies the front disc brakes.

44. Brake pad wear indicators are fitted to the front left hand caliper and will actuate a brake circuit warning light on the dashboard when brake pad thickness is reduced to approximately 3 mm. In addition, the warning light will illuminate if fluid loss occurs from either the primary or secondary brake circuit.

Parking brake

45. A single drum brake is mounted on the intermediate axle output shaft of the transfer case. This brake, which is mechanically operated by the parking brake lever in the cab. Is completely independent of the foot operated hydraulic brake system.

Instruments, electrical accessories and controls (see Fig. 1-24)

46. Ventilator control (Fig. 1-24 items 1 and 12)

Two ventilators are provided in the windscreen frame, which may be opened independently by pushing the appropriate control lever downward.

47. Normal, blackout and reduced lighting switch (Fig. 1-24 item 2).

This three position switch, located on the fascia panel, controls the vehicle lighting as follows:

- a. In the NORMAL or left position, all vehicle lighting operates via the usual controls.
- b. In the BLACKOUT or mid position, all of the NORMAL lighting, with the exception of dash instrument, warning and map reading lights, is switched off. In this mode, the blackout stop lights will function when the brakes are applied, and the blackout marker lights at the front and rear of the vehicle are illuminated. The convoy light also operates in this mode.
- c. In the REDUCED or right position, the reduced head lights are utilized in addition to the blackout lighting. The dash instrument lights and map reading light can also be used.

48. Auxiliary power socket (Fig. 1-24 item 3)

A two pin socket is fitted in the dash as a power supply for the vehicle trouble light lead.

49. Panel light dimmer control (Fig. 1-24 item 4)

The instrument panel light intensity can be adjusted by the dimmer control, which functions irrespective of which of the three modes of lighting is selected. The switch also has an ON-OFF control.

50. Heater fan control switch (Fig. 1-24 item 5)

A three position rocker switch controls the heater fan as follows:

- a. With the switch in the off position the heating and ventilation system is inoperative.

- b. Low speed or high speed fan operation is provided when the switch is moved down to the first or second stop respectively. Air will be forced into the vehicle then ducted and heated as determined by the air distribution and heat control levers. The fan motor will only operate with the engine running or with the ignition on.

51. Air temperature control (Fig. 1-24 item 6)

The temperature control lever controls the temperature of the air from the heater unit. Moving the lever up in the direction of the blue arrow will cut off the heat, while moving the lever down toward the red arrow will increase the heat (see Fig. 1-4). Action is progressive between the two settings.

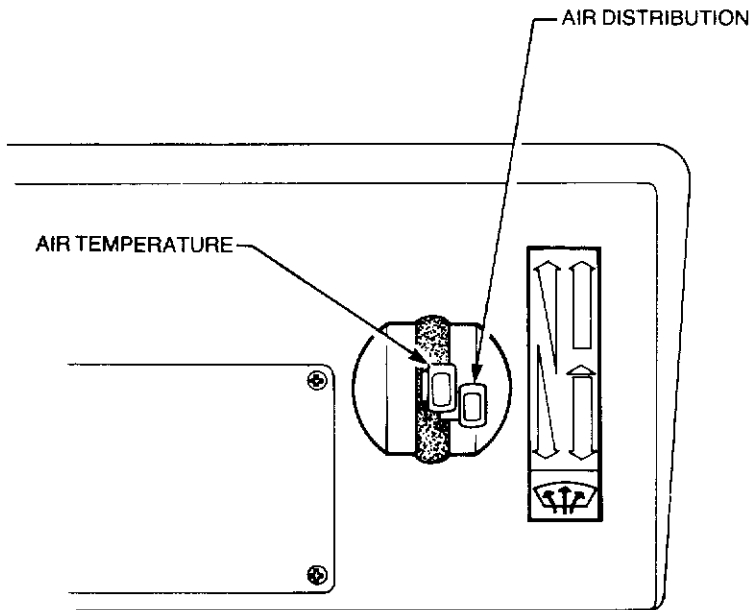

Figure 1-4 Air temperature and distribution controls

52. Air distribution control (Fig. 1-24 item 7)

The air distribution control lever controls the direction of air flow as follows (see Fig. 1-4).

- a. With the lever in the lower position, all air is directed to the windscreen via the demister vents.

- b. With the lever in the mid position, air is directed to the foot level vents as well as the windscreen.
- c. With the lever in the upper position, the air is directed to the foot level vents although a certain amount of air will continue to pass through the demister vents to the windscreen.

53. Fuel switch (Fig. 1-24 item 8)

A two position toggle switch is located on the dash, which when operated determines which fuel tank, fuel will be drawn from.

54. Transfer case control switch (Fig. 1-24 item 9)

The transfer case is fitted with a differential which allows the vehicle to be operated on road without transmission wind-up. The differential is lockable, to provide positive drive to the axles when necessary, and is controlled by a dash mounted two position switch. The switch should be pushed in for on road use and pulled out when traction is difficult, thereby providing positive six wheel drive.

55. Combination switch (Fig. 1-24 item 10)

The combination switch has six positions and provides control over the headlights, turn indicators and the horn. The switch operates as follows (see Fig. 1-5):

- a. With the switch in the central position (A), the headlights will be dipped.
- b. With the switch pushed away from the driver (B), the headlights will be on high beam.
- c. Pulling the switch toward the driver (C), will flash the headlights. This operation can be achieved at any time, irrespective of other switch positions.
- d. Pushing the switch knob inward (D), will operate the horn.
- e. With the switch in the upper position (E), the right hand turn indicators will flash.
- f. With the switch in the lower position (F), the left hand indicators will flash.

The combination switch functions are not available during blackout conditions.

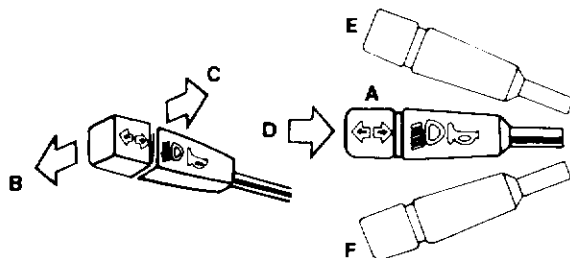

Figure 1-5 Combination switch operation

56. Speedometer and odometer (Fig. 1-24 item 11)

The speedometer indicates the road speed in kilometres per hour and the total distance travelled. A trip meter is incorporated in the speedometer together with its associated reset button.

57. Fuel gauge (Fig. 1-24 item 13)

One fuel gauge services both the left and right hand mounted fuel tanks. The approximate contents of each tank can be assessed by operating a dual purpose dash mounted switch — fuel will only be drawn from the tank indicated.

58. Warning light cluster (Fig. 1-24 item 14)

The warning lights provide a visual indication that a fault has occurred in one or more of the systems represented by the warning lights.

- a. The oil pressure warning light (Fig. 1-6 item 2) indicates when the oil pressure is insufficient for safe engine operation. The light should illuminate when the ignition is turned on and extinguish once normal engine oil pressure is established. If this light illuminates during normal running, the vehicle should be stopped immediately and the cause determined.
- b. The ignition warning light (Fig. 1-6 item 3) indicates a malfunction in the battery charging circuit. The light should illuminate when the ignition is turned on and extinguish once the engine is running.
- c. The brake circuit warning light (Fig. 1-6 item 4) indicates that leakage has occurred from either the front or rear brake circuit. In this case, the light will illuminate when the foot brake is applied. In addition, a brake pad wear indicator is fitted to the front left hand caliper and will actuate the light when the pad thickness is reduced to approximately 3 mm. Normally, the light will illuminate momentarily

when the ignition is turned on, then extinguish. If the light illuminates during normal running, the vehicle should be stopped immediately and the cause determined.

- d. The turn indicator warning light (Fig 1-6 item 5) flashes when the turn indicator lights are functioning. Both arrows will flash as the turn indicator is operated by the switch on the steering column. If the light does not flash, there may be a blown globe in the warning light or one of the turn indicators.
- e. The high beam warning light (Fig 1-6 item 6) illuminates when the headlight high beam has been selected. The light also illuminates when the head light flasher is used.
- f. The low fuel warning light (Fig. 1-6 item 7) illuminates when there is approximately nine litres of fuel left in either fuel tank and will remain illuminated until the fuel supply is replenished. When cornering, the light may flash intermittently before the fuel reaches the nine litre level.
- g. Both the differential lock warning light (Fig. 1-6 item 8) and the six wheel drive light (Fig. 1-6 item 1) will illuminate when the transfer case differential lock is engaged. This is necessary when traction to one or more wheels is likely to be lost.
- h. The parking brake warning light (Fig. 1-6 item 12) will illuminate if the parking brake is applied while the ignition is on.
- i. The trailer warning light (Fig. 1-6 item 13) provides an indication that the turn indicators on a towed trailer are functioning correctly. The light will flash simultaneously with the vehicle turn indicator warning light when a trailer is connected to the vehicle's NATO socket. When no trailer is used, the light will flash momentarily each time the combination switch is moved up or down. In addition, the trailer warning light will flash when the hazard warning switch is activated.
- j. The park light warning light (fig. 1-6 item 15) indicates when the park lights have been switched on.
- k. The cold start warning light (Fig. 1-6 item 17) illuminates when the starter switch is in the glow plugs on position.

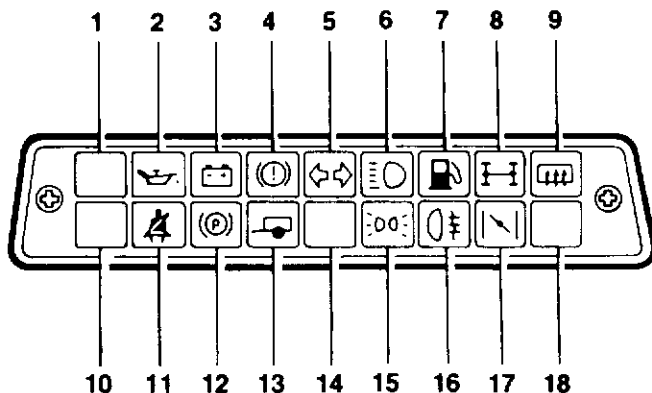

- | | | |
|-----|-------------------------|-------|
| 1. | 6 wheel drive | Red |
| 2. | Oil pressure | Red |
| 3. | Ignition | Red |
| 4. | Brake circuit | Red |
| 5. | Turn indicators | Green |
| 6. | High beam | Blue |
| 7. | Low fuel | Amber |
| 8. | Differential lock | Amber |
| 9. | Not used | Amber |
| 10. | Not used | Red |
| 11. | Not used | Red |
| 12. | Parking brake | Red |
| 13. | Trailer | Green |
| 14. | Not used | Green |
| 15. | Park lights on | Green |
| 16. | Not used | Amber |
| 17. | Cold start (glow plugs) | Amber |
| 18. | Not used | Amber |

Figure 1-6 Warning lights

59. Coolant temperature gauge (Fig. 1-24 item 15)

Under normal running conditions, the temperature gauge needle should be within the green band. When operating in high ambient temperatures, with heavy loads or on steep grades at high altitudes, the operating temperature could rise. However, if the needle rises into the red band, the vehicle should be stopped and the cause determined.

60. Voltmeter (Fig. 1-24 item 16)

The voltmeter measures the vehicle system voltage. With the engine running above idle speed, the needle should be within the green band (12-14 volts). A reading above this in the high red band, which contin-

ues after approximately ten minutes, is too high and should be investigated. Similarly, a reading in the low red band which continues after approximately ten minutes, with no electrical load switched on, is too low and should also be investigated.

61. Windscreen washer and wiper switch (Fig. 1-24 item 17)

The windscreen washer and wiper switch is a five position switch, which only operates when the ignition is on. Switch operation is as follows (Fig. 1-7).

- a. With the switch in the upper position (A), fast wiper action is achieved.
- b. With the switch in the second position (B), slow wiper action is achieved.
- c. With the switch in the third position (C), the wipers are off.
- d. With the switch in the lower position (D), the wipers will operate at the slow speed until the switch is released.
- e. Pushing the switch knob inward (E) will activate the windscreen washer, which will spray water on the windscreen until the knob is released. This can be achieved with the switch on or off.

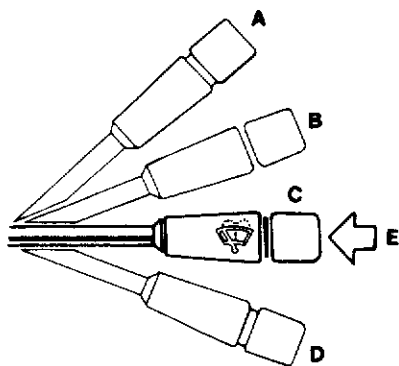

Figure 1-7 Windscreen washer and wiper control

62. Cab dome light switch (Fig. 1-24 item 18)

The cab dome light switch is a two position rocker action switch. Pressing the lower section of the switch turns the dome light on and pressing the upper section of the switch turns the dome light off (see Fig. 1-8). The dome light will not function during blackout conditions.

63. Hazard warning switch (Fig. 1-24 item 19)

The hazard warning switch is a two position rocker action switch. By pressing the lower section of the switch, both the left and right hand turn indicators, together with the side repeaters, flash simultaneously. A globe in the switch also illuminates to indicate that the switch is on. In addition, the trailer warning light will flash when the hazard warning switch is activated. Pressing the upper section of the switch turns the hazard warning lights (see Fig. 1-8). Hazard warning lights will not function during blackout conditions.

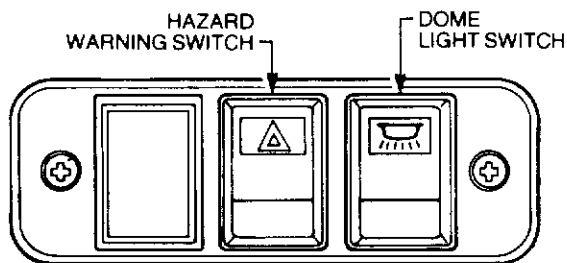

Figure 1-8 Hazard warning and cab dome light switches

64. Hand throttle (Fig. 1-24 item 20)

The hand throttle control can be used to over-ride the accelerator pedal to set engine speed. To utilize the hand throttle, first set the engine speed with the accelerator then pull out the hand throttle and turn the control to lock it in position. The accelerator will over-ride the hand throttle setting when increasing the engine speed. However, when the accelerator is released, the engine will return to the speed set by the hand throttle. To release the hand throttle, turn the knob and push the control fully down to the closed position.

65. Bonnet release (Fig. 1-24 item 21)

The bonnet release handle is located to the right of the steering column, and by pulling the handle, the bonnet catch will release. From the front of the vehicle, lift the safety catch lever and raise the bonnet. Pull the support stay forward to secure the bonnet in the open position. The bonnet safety catch is illustrated in Fig. 1-9.

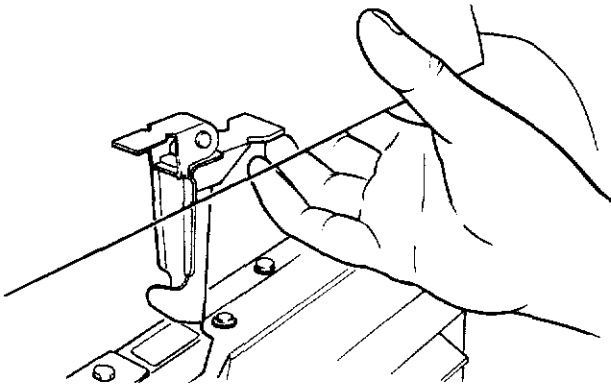

Figure 1-9 Bonnet safety catch

66. Accelerator pedal (Fig. 1-24 Item 22)

The accelerator pedal controls the engine speed via the accelerator cable. Depress the pedal to increase engine speed.

67. Foot brake pedal (Fig. 1-24 Item 23)

The foot brake pedal controls the application of the service brakes to all four wheels. Depress the pedal progressively to apply increased braking pressure.

68. Starter switch (Fig 1-24 Item 24)

The starter switch is a four position switch, providing control over the ignition, glow plugs and starter motor. The switch is turned clockwise to activate the vehicle electrical system.

69. Main lighting switch (Fig. 1-24 Item 25)

The main lighting switch is a three position switch, providing control over the lighting as follows (see Fig. 1-10).

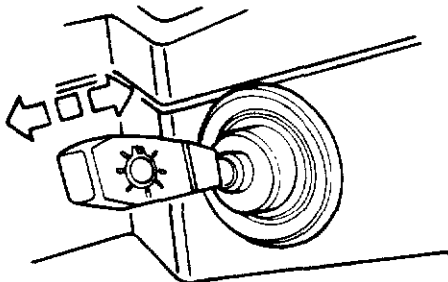

Figure 1-10 Main lighting switch

- a. With the switch pulled toward the driver, all lights will be off.
- b. With the switch in the centre position, the park lights will be illuminated.
- c. With the switch pushed away from the driver, both the main and park lights will be illuminated.

70. The main lighting switch will not function during blackout conditions.

71. Clutch pedal (Fig. 1-24 item 26)

Depress the clutch pedal to disengage the clutch.

72. Cigar lighter (Fig. 1-24 item 27)

Push the lighter in to operate. The lighter will automatically return to the normal position when ready for use.

73. Parking brake lever (Fig. 1-24 item 28)

The parking brake is applied by pulling the lever up. To release the brake, pull the lever slightly up, depress the release button and push the lever down. Application of the parking brake will illuminate a warning light on the instrument panel.

74. Gear lever (Fig. 1-24 item 29)

The gear lever is used to manually change the gear ratios in the transmission. The gear change pattern is illustrated in Fig. 1-11.

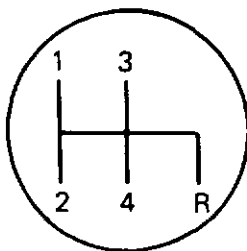

Figure 1-11 Gear change pattern

75. Transfer case shift lever (Fig. 1-24 item 30)

The transfer case shift lever provides the manual selection of high or low gear ratios as required. The ratio shift pattern is illustrated in Fig. 1-12.

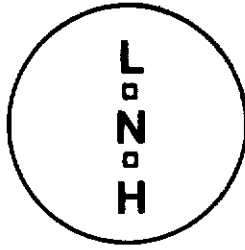

Figure 1-12 Transfer case shift pattern

76. Fuse Box (Fig. 1-24 Item 31)

Removing the fuse box cover allows access to the fuses. The location of each fuse is provided by the decals as shown in Fig. 1-13.

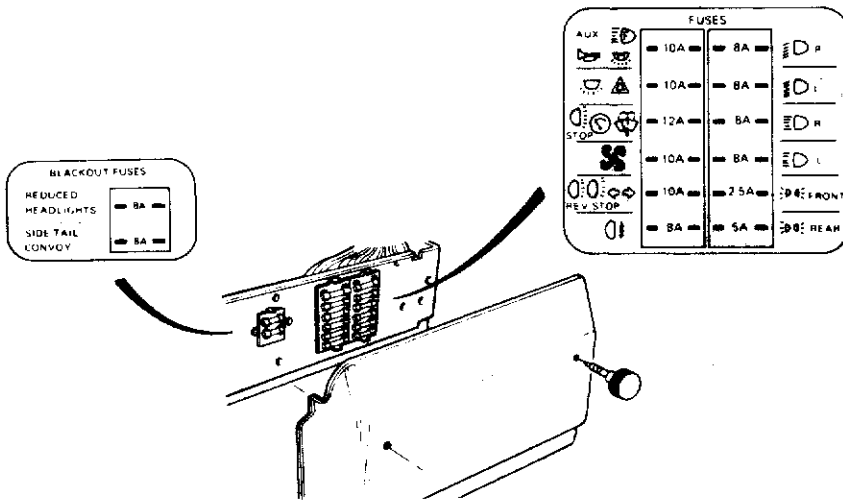

Figure 1-13 Fuses

77. The stop/start control motor is protected by a 10 amp fuse located under the bonnet to the side of the brake master cylinder.

78. Map reading light (Fig. 1-24 item 32)

The map reading light switch is located on the end of the light unit. The light can only be utilized when the ignition is on.

79. Cabin seating (Fig. 1-14)

The central cabin seat back can be tilted forward and utilized as a platform by the observer using the roof hatch, and the fore and aft movement can be adjusted as illustrated in Fig. 1-14.

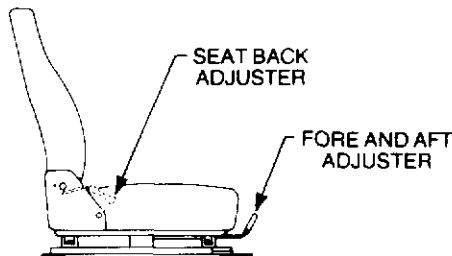

Figure 1-14 Seat adjustment

Body and Chassis Fittings

80. Vehicle body construction

The chassis frame is an all welded construction type, consisting of box section steel runners and crossmembers. The frame is hot dipped galvanized to prevent the formation of rust. One crossmember is detachable to simplify servicing. The body consists of pressed aluminium and fibreglass panels that form the engine compartment bolted to a galvanized steel cabin.

81. The cargo tray is fabricated from aluminium extrusions and is fitted with removable dropsides and a canvas canopy. Longitudinal bench seating is provided in the cargo area for twelve fully-kitted troops.

NOTE

The body, chassis and engine have certain common features with other variants to allow for variant transfer throughout the life of the fleet. It is not intended that this occur regularly but allow flexibility in fleet management should circumstances dictate.

82. Stowage

A stowage bin is provided in each side of the rear body section, behind the rear wheels. These bins are lockable and the key is located in a canvas pocket secured to the driver's door.

83. Rear window (Fig. 1-15)

A sliding window is fitted to the rear of the cab to allow communication with the front and rear passengers.

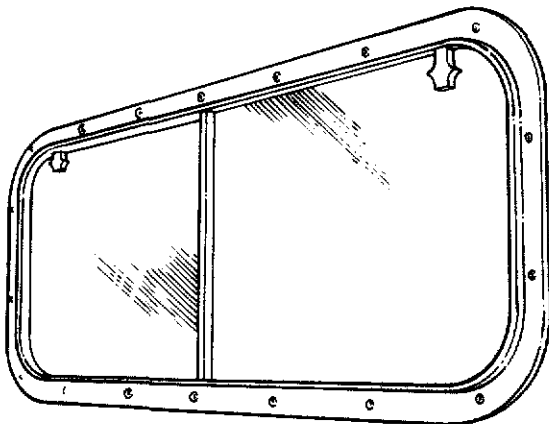

Figure 1-15 Rear Window

84. Roof Hatch (Fig. 1-16)

A roof hatch is fitted to the roof panel to provide an observation hatch.

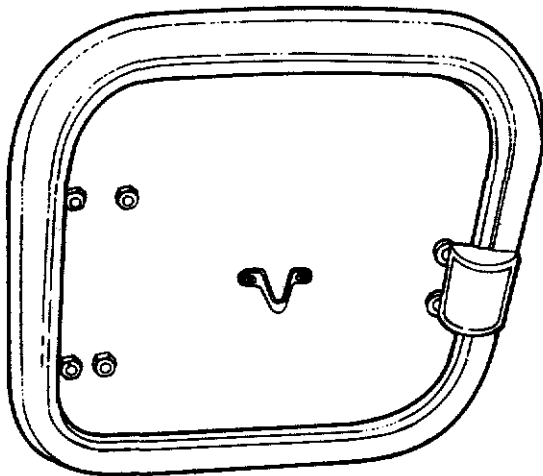

Figure 1-16 Roof Hatch

85. Rear side windows (Fig. 1-17)

Rear side windows are fitted to the cabin to provide ventilation. They may be locked in either the open or closed position by an over-centre catch.

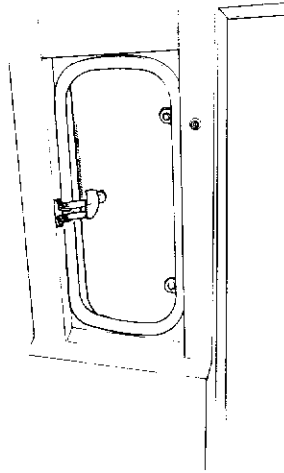

Figure 1-17 Rear Side Window

86. Jerrican stowage

Two jerricans can be stowed, in carriers, on the right hand side of the vehicle behind the cab.

87. Rifle clips and butt boxes

There are facilities to mount two rifles between the seats in the cabin.

88. Fire extinguisher

A 1.5 kg BCF Fire Extinguisher is fitted on the rear bulkhead, behind the cabin seats.

89. De-ditching tools

The de-ditching tools are mounted in brackets fitted to the bonnet. The tools comprise one axe, one shovel and one pick with handle.

90. Spare wheel stowage and lowering assembly

The spare wheel is stowed under the vehicle behind the rear axle and is secured by a chain. The wheel is lowered from the stowed position by using the wheel brace to operate a winch drive (see Fig. 1-18) situated behind the left hand rear mudguard. The spare wheel is positively locked in the travelling position by a brake in the winch mechanism. When raising the spare wheel an additional resistance to movement of the wheelbrace, indicates the spare is correctly stowed. The spare

wheel can be lowered by rotating the wheel brace in a counter clockwise direction.

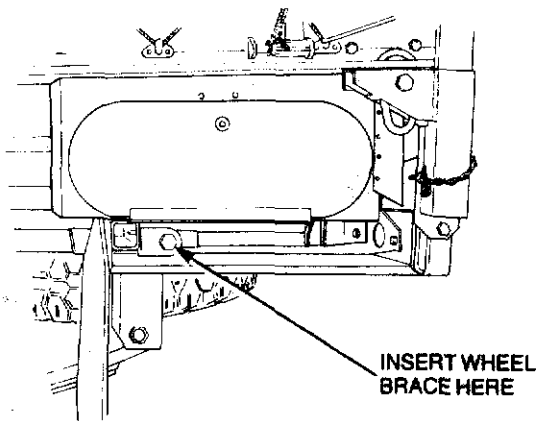

Figure 1-18 Spare wheel lowering

91. Electrical trailer connection sockets

A 12 pin NATO trailer connection socket is fitted to the rear of the left hand chassis rail. Also an additional 7 pin plug is fitted to the rear of the left hand chassis rail. This plug is not to be used as a trailer connection.

92. Towing pintle

An approved towing pintle is fitted to the rear of the vehicle.

93. Seat belts

Inertia reel lap/sash seat belts are fitted to the outer cabin seats. The centre seat has a lap belt only fitted.

94. Rear vision mirrors

The external rear vision mirrors are hinged to fold back (inward) when knocked or bumped, thus reducing damage during cross country operations.

95. Vehicle nomenclature plate (Fig. 1-19)

The vehicle manufacturer's identification number is stamped on a plate that is riveted to the passenger's seat box. The identification number is also stamped on the right hand side of the chassis, forward of the spring mounting turret.

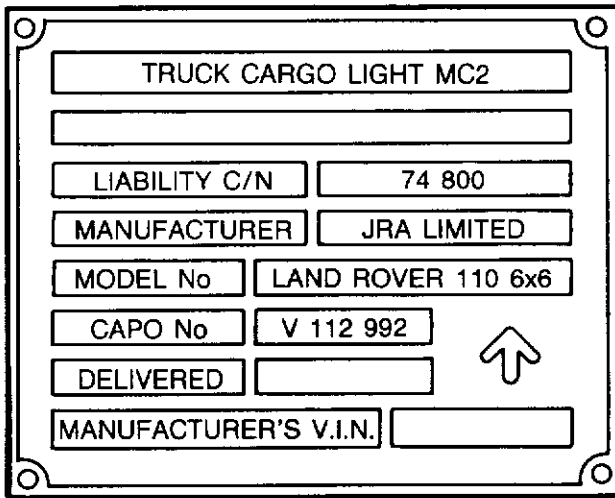

Figure 1-19 Vehicle nomenclature plate

96. Servicing data plate (Fig. 1-20)

The vehicle servicing data plate is riveted to the passenger's seat box, adjacent to the vehicle nomenclature plate.

SERVICING DATA				
				HYG3002
COLD TYRE PRESSURES (kPa)		HIGHWAY	CROSS COUNTRY	SAND
	FRONT	250	200	150
	REAR	350	275	225
LUBRICATION — NORMAL OR TROPICAL TEMPERATURES				
ENGINE	OMD 115	MASTER CYLS	OX (AUST.) 8	
GEARBOX	OMD 115	MANUAL STG. BOX	OEP 220	
TRANSFER BOX	CASTROL FMX	POWER STG. BOX	OX46 or OX47	
POWER TAKE-OFF	CASTROL FMX	LUBE. NIPPLES	XG274	
AXLES	OEP 220	WINCH	OEP 220	
SWIVEL PIN H'SING	OEP 220			
ELECTRICAL — 12 VOLT NEGATIVE TO EARTH SYSTEM				

Figure 1-20 Servicing data and tyre pressure plate

97. Shipping data plate (Fig. 1-21)

A shipping data plate is riveted to the passenger's seat base just below the servicing date plate.

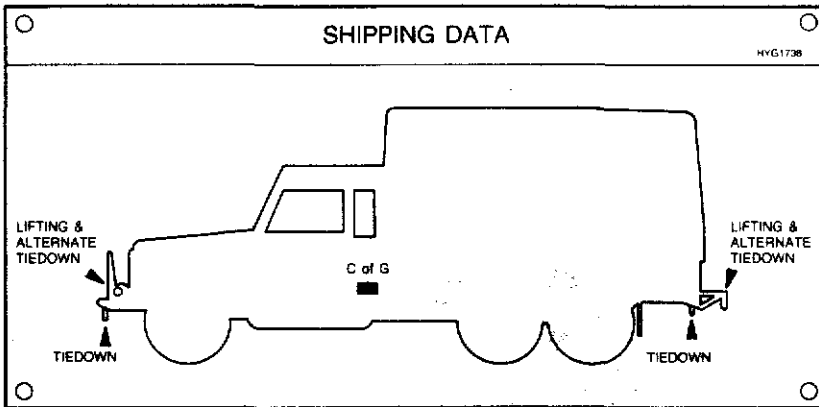

Figure 1-21 Shipping data plate

98. Towing and dyno test data plate (Fig. 1-22)

The towing and dyno test plate is riveted to the driver's seat box. See para 233 for propeller shaft removal precautions.

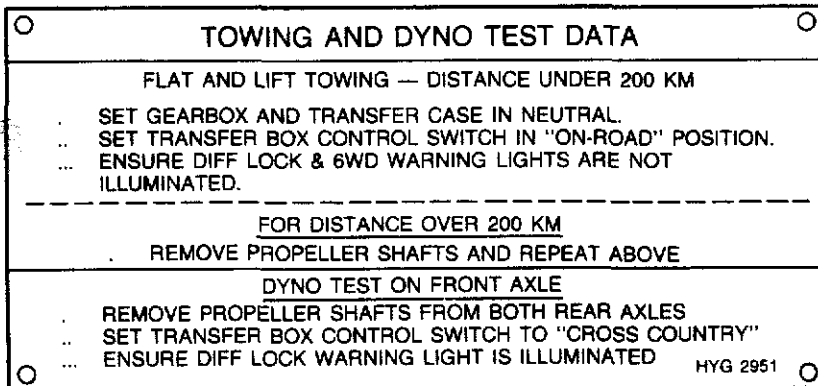

Figure 1-22 Towing and dyno test data plate

99. Jacking plate (Fig. 1-23)

A jacking plate is fitted to the stowage lid as well as to the jack itself.

JACKING PROCEDURE

HYG 1764

DUE TO THE FITMENT OF A TRANSMISSION HANDBRAKE TO THIS VEHICLE, THE JACKING PROCEDURE MUST BE FOLLOWED BEFORE JACKING ANY WHEEL CLEAR OF THE GROUND.

1. APPLY HANDBRAKE.
2. ENGAGE DIFFERENTIAL LOCK (WARNING LIGHT WILL ILLUMINATE).
3. SELECT 1ST GEAR — LOW RANGE.
4. CHOCK BOTH SIDES OF WHEEL FURTHEST FROM WHEEL BEING RAISED.
5. SLACKEN WHEEL NUTS (5).
6. FRONT WHEELS: POSITION JACK UNDER AXLE CASING IMMEDIATELY BELOW ROAD SPRING BETWEEN END FLANGE AND SUSPENSION BRACKET.
REAR WHEELS: POSITION JACK UNDER AXLE CASING IMMEDIATELY BELOW ROAD SPRING NEAR DAMPER.
7. REPLACE WHEEL AND TIGHTEN NUTS.
8. LOWER VEHICLE.
9. TORQUE NUTS: 100-115 Nm (75-85 lb. ft.).
10. DISENGAGE DIFFERENTIAL LOCK BEFORE MOVING OFF.

Figure 1-23 Jacking procedure plate

100. Centre of gravity (C of G) designation plate

A "C of G" plate designating the longitudinal point of balance of the unladen vehicle is fitted to the left hand sill panel. See Fig. 1-3.

101. Unit/formation signs

Four unit/formation sign holders are fitted to the vehicle. Two are riveted just below the head lights and the other two are attached to the rear crossmember.

102. Bridge classification sign

Due to the size and weight of this vehicle, no bridge classification sign is fitted.

103. Camouflage net lashing points

Lashing points are provided on each side of the vehicle for securing camouflage equipment.



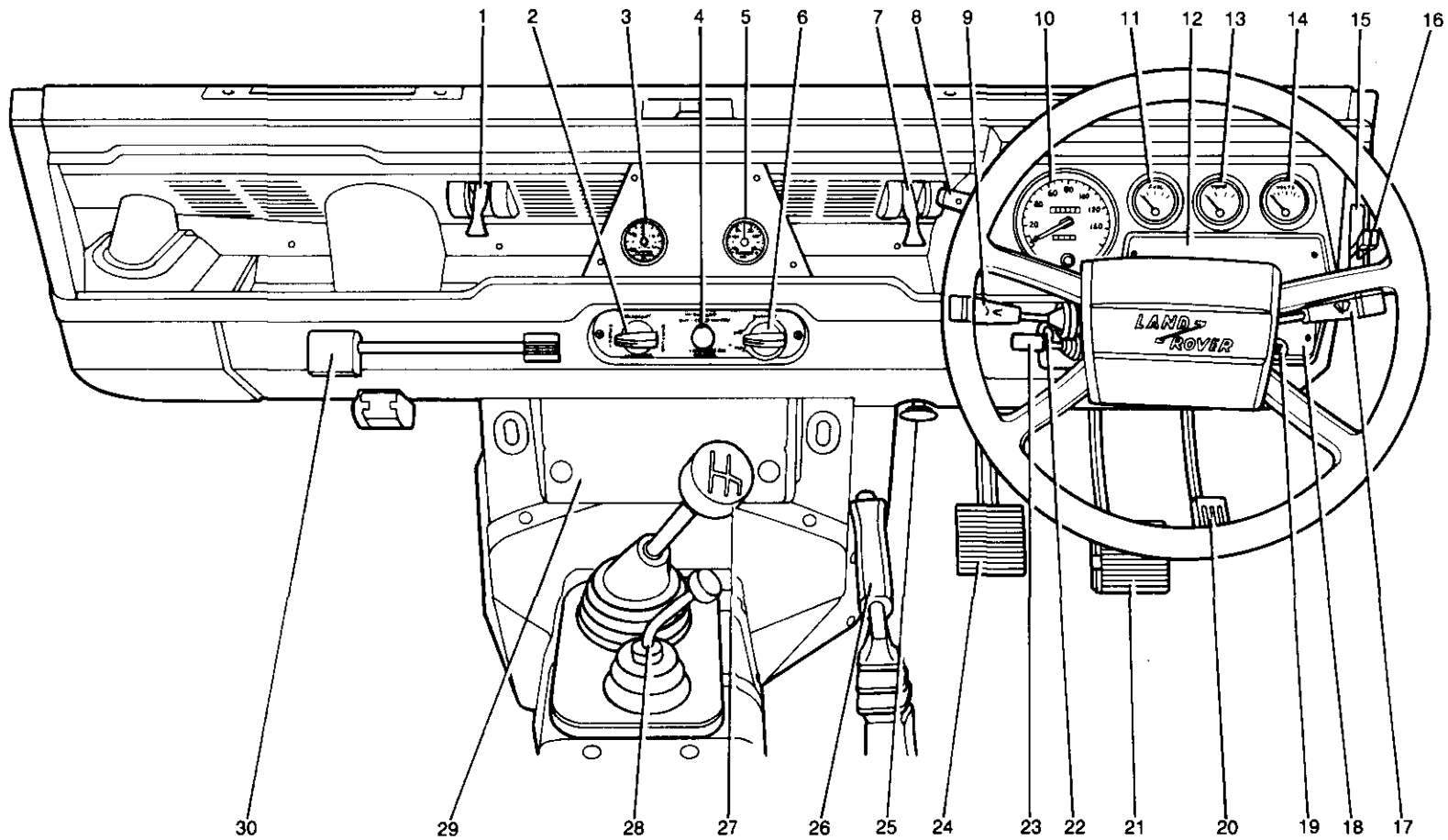

- 1. Ventilator control
- 2. Lighting control
- 3. Hourmeter
- 4. Transfer case control
- 5. Ammeter
- 6. Panel light dimmer control
- 7. Ventilator control
- 8. Heater fan control
- 9. Combination switch
- 10. Speedometer

- 11. Fuel gauge
- 12. Warning light cluster
- 13. Coolant temperature gauge
- 14. Voltmeter
- 15. Air temperature control
- 16. Air distribution control
- 17. Windscreen washer and wiper switch
- 18. Hazard warning and interior lighting switches
- 19. Hand throttle
- 20. Accelerator pedal

- 21. Foot brake pedal
- 22. Starter switch
- 23. Main lighting switch
- 24. Clutch pedal
- 25. Bonnet release
- 26. Parking brake lever
- 27. Gear lever
- 28. Transfer case shift lever
- 29. Fuse box
- 30. Map reading light

Figure 1-28 Instruments, electrical accessories and controls



CHAPTER 2

OPERATING INSTRUCTIONS

SECTION 1 — WARRANTY AND REPAIR

SECTION 2 — VEHICLE OPERATION

SECTION 1

WARRANTY AND REPAIR

Warranty provisions

201. The Contractor (JRA Limited) accepts responsibility for warranty in respect to the whole vehicle (except GFE items other than the mounting of such items) for a period of 12 months or 20 000 km, whichever occurs first from the time of issue of vehicle to user unit. Where vehicles are delivered to supply depots for extended storage, the depot becomes the user unit.

202. Where a vehicle is delivered into storage, provision is made for the warranty to be suspended for up to two years. Should the vehicle enter service during the two year period, then a pro-rata warranty applies in accordance with Table 2-1.

Table 2-1 Pro-rata warranty

Time of Withdrawal from Storage (measured from day of delivery into storage)	Period of Warranty after Withdrawal from Storage	
	Distance (km)	Time (mths)
(whichever expires first)		
First day of 1st month — last day of 3rd month	20 000	11
First day of 4th month — last day of 6th month	18 000	10
First day of 7th month — last day of 9th month	16 000	9
First day of 10th month — last day of 12th month	14 000	8
First day of 13th month — last day of 15th month	12 000	7
First day of 16th month — last day of 18th month	10 000	6
First day of 19th month — last day of 21st month	8 000	5
First day of 22nd month — last day of 24th month	6 000	4*
First day of 25th month — last day of 27th month	3 000	3*

***NOTE:** The warranty finally expires after twenty-seven (27) months irrespective of any outstanding distance or time pro-rata warranty.

Special provisions

203. The warranty shall not apply where failure arises from:

- a. Vehicle not being maintained in accordance with User Handbook or EMEI manuals.
- b. EMEI storage procedures not being effectively applied.
- c. Misuse or neglect.
- d. The fitting of non-genuine parts and where it is mutually agreed as a contributing factor.

- e. The use of equipment not normally or reasonably associated with the operation of the supplies.
- f. Supplies that have been altered in form or function without consultation with and approval of the Contractor.
- g. Any part or parts of which the specification has been altered by the Commonwealth without the Contractor's approval.
- h. Any part or parts from which the identification marks or numbers have been altered or removed by the Commonwealth.
- i. Repairs which involved or resulted from either directly or indirectly the use of non-genuine parts.
- j. Incorrect tuning, adjustments or maintenance operations which are associated with periodic servicing requirements.
- k. Parts or equipment which have not been supplied by the Contractor or by a supplier approved by the Contractor and any problems which may arise, either directly or indirectly from the fitment of such equipment.
- l. The consequences of the supplies having been repaired by a non-approved repairer. For the purpose of this clause, approved repairer shall include Army vehicle maintenance personnel.

Application of warranty

204. The application of the warranty will be by repair or replacement of the defective component at no cost to the Commonwealth.

205. Provision is made for warranty repairs to be carried out by JRA Limited authorised Land Rover dealers and a list of such dealers is included in this publication.

206. However, if for reasons of distance, location etc., it is not practical to have the necessary repairs carried out by a JRA Limited authorised Land Rover dealer, then an Army tradesman is approved to carry out the repair. This procedure should be adopted in the case of emergency or essential repairs only (e.g. for safety, prevention of further damage or an operational requirement).

207. In such circumstances, JRA Limited will reimburse the Army for parts used at cost and labour at standard repair times and the prevailing Land Rover dealer warranty hourly labour rate.

208. The information required to be documented by the Army unit in such circumstances is:

- a. Identify the vehicle by chassis and or Army registration

number.

- b. Date vehicle entered service (if known).
- c. Current odometer reading.
- d. Nature of failure (brief explanation).
- e. Nature of repair necessary.
- f. Parts replaced by designation and part number.
- g. Time taken or Standard Repair Time (SRT) and operation number (refer to EMEI VEH A119-22).
- h. If parts were procured through a Land Rover dealer, then documentation identifying purchase and price paid.
- i. JRA Authority Number (if applicable).

209. The procedure for submitting a claim to JRA Limited to obtain reimbursement is defined in EMEI VEH A119-22.

Prior consultation

210. Where a vehicle is presented to an authorised JRA Limited land Rover dealer for warranty repairs, the Army need not be concerned as the dealer has adequate authority to deal with most situations and the necessary procedure to obtain authority in the case of major repairs.

211. In circumstances where the army are themselves undertaking a warranty repair, this may proceed without authority provided the estimated total material and labour cost is less than \$500. If the cost is estimated to be in excess of \$500, then the appropriate JRA Limited State Office listed in Table 2-2 should be contacted for authority and guidance.

212. The person making the contact should have the following information available:

- a. Vehicle chassis and Army registration number.
- b. Date in service (if known).
- c. Current odometer reading.
- d. Knowledge of the problem encountered.

Continuance of warranty following a warranty repair

213. Any supplies corrected or furnished by way of replacement under warranty claim, whether it be an initial equipment supply or replacement part, will enjoy the balance of any existing warranty.

Warranty on replacement parts and MSI's

214. Except when fitted in the execution of a warranty repair,

replacement parts and MSI's enjoy the same warranty as the vehicle and in general terms as applicable the same special provisions apply (see para. 203).

Table 2-2 JRA State Offices

JRA State Offices	Telephone	Telex	Facsimile
N.S.W. Cnr. Heathcote Rd. and Church St., LIVERPOOL NSW 2170	(02) 600 1333	25375	(02) 602 1759
VIC. (TAS.) Level 1, Southgate 10 Jamieson St., CHELTENHAM VIC 3192	(03) 581 5600	—	(03) 581 5660
QLD. Cnr St Pauls Terr. and Brunswick St., FORTITUDE VALLEY QLD 4006	(07) 854 1599	42311	(07) 52 3776
S.A. (N.T.) 164 Fullerton Rd., DULWICH S.A. 5065	(08) 332 7799	—	(08) 364 0456
W.A.. 6 Glassford Rd., KEWDALE W.A. 6105	(09) 353 1499	—	(09) 353 1498

List of agents

215. Table 2-3 details the Land Rover dealers throughout Australia and their repair level capability. This list was correct at the time of printing. A list of current Land Rover dealers is available from JRA State Offices.

Table 2-3 Land Rover dealers

Agent	Repair Level
Queensland (1 MD)	
Atherton Aldridge Motors Pty Ltd (070- 91 1468) 18 Mabel Street Atherton QLD 4883	Unit

Table 2-2 Land Rover dealers (cont'd)

Agent	Repair Level
Brisbane Westco Rover (07- 844 0221) 79 Melbourne Street South Brisbane QLD 4104	Base
Bundaberg Alan Powell Jaguar Rover (071- 72 9666) 26 Bourbong Street Bundaberg QLD 4670	Field
Burketown Nowland Engineering (011- 077- 45 5107) via exchange) Gregory Street Burketown QLD 4830	Field
Caloundra Pacific Jaguar Rover (071- 91 1344) 32 Bowman Road Caloundra QLD 4551	Base
Cairns John Broadley Jaguar Rover (070- 51 1188) 94 McLeod Street Cairns QLD 4870	Base
Cooktown Peninsula Auto Services (070- 69 5327) 10 Boundary Street Cooktown QLD 4871 Phil Witheridge (Prop.)	Field
Gympie Gympie Carworld (071- 82 2822) 69 Monkland Street Gympie QLD 4570	Field

Table 2-2 Land Rover dealers (cont'd)

Agent	Repair Level
Mackay Carlisle Motors Pty Ltd (079- 57 2971) 36 Gregory Street Mackay QLD 4740	Base
Maryborough Jack Casey Motorworld (071- 21 2545) 103 Lennox Street Maryborough QLD 4650	Base
Mount Isa Ian Brien Ford (077- 43 4622) 59 West Street Mount Isa QLD 4825	Base
Normanton Top Service Station (077- 45 1261 STD) (077- 40 7777 via exchange) Landsborough Street Normanton QLD 4890	Field
Southport Southport Motors (075- 32 0399) Cnr Minnie and Anne Streets Southport QLD 4215	Base
Toowoomba Alan Flohr Jaguar Rover (076- 34 3233) Cnr James and Anzac Avenues Toowoomba QLD 4350	Base
Townsville Tony Ireland Jaguar Rover (077- 71 6855) 87 Charters Towers Road Townsville QLD 4810	Base

Table 2-2 Land Rover dealers (cont'd)

Agent	Repair Level
Virginia Grand Prix Nominees Pty Ltd (07- 265 1000) Cnr Robinson Road and Hadley Street Virginia QLD 4014	Base
Weipa Weipa Servicentre (070- 69 7277) Boundary Road Weipa QLD 4874	Field
Yeppoon Citimotors (079-39 3811) 72 Tanby Road Yeppoon QLD 4703	Base
New South Wales (2 MD)	
Albury Albury Motors (060- 21 2188) 475 Olive Street Albury NSW 2640	Base
Arncliffe Purnell Motors (02- 59 0241) 139 Princes Highway Arncliffe NSW 2205	Base
Artarmon New Rowley Motors (02- 436 0857-0987) 393 Pacific Highway Artarmon NSW 2064	Base
Bega Tarra Rover (0649- 2 1666) 151 Auckland Street Bega NSW 2550	Field

Table 2-2 Land Rover dealers (cont'd)

Agent	Repair Level
Bombala Lomas' Garage (0645- 8 3311) 80-86 Maybe Street Bombala NSW 2553	Field
Broken Hill Commonwealth Motors (080 2624) 405 Crystal Street Broken Hill NSW 2880	Field
Carlton Lindsay Johnstone (02- 546 3211) 57 Planthurst Road Carlton NSW 2218	Base
Casino Capitol Car Sales (066- 62 1477) Centre Street Casino NSW 2470	Unit
Coffs Harbour Autocare (066- 52 1422) 115 High Street Coffs Harbour NSW 2450	Field
Dubbo Sainsbury Toyota (068-82 1511) Bourke Street Dubbo NSW 2830	Unit
Dungog Modern Motors (049- 92 1486) 282 Dowling Street Dungog NSW 2420	Field
Gosford/Wyoming Regal Motors (043- 28 2888) Frances Parke Drive Wyoming NSW 2250	Base

Table 2-2 Land Rover dealers (cont'd)

Agent	Repair Level
Hamilton Regal Motors (049- 62 1011) 67 Tudor Street Hamilton NSW 2303	Base
Homebush Asquith and Johnstone Pty Ltd (02- 764 1777) 145 Parramatta Road Homebush NSW 2140	Base
Hurstville Arthur Garthon Motors (02-588 5000) 71 Forest Road Hurstville NSW 2220	Base
Lismore John Chant Motors Pty Ltd (066- 21 2601) Cnr Ballina and Brewster Streets Lismore NSW 2480	Unit
Moorebank Wrendco Automotive Repairs (02- 600 6537) 8 Seton Road Moorebank NSW 2170	Base
Murwillumbah Youngblutt Car Sales Pty Ltd (066- 72 1963) 389 Pacific Highway Murwillumbah NSW 2480	Field
Nowra Tory Classic Cars (044- 210 922) Kinghorn Street Nowra NSW 2540	Field
Singleton R. and E. Teasdale Pty Ltd (065- 72 1655) 64 George Street Singleton NSW 2330	Field

Table 2-2 Land Rover dealers (cont'd)

Agent	Repair Level
Sydney (City) City Automobiles (02- 33 0678) 123 William Street Sydney NSW 2000	Base
Tamworth Clifton's Pty Ltd (067- 65 3000) Cnr In and Hercules Streets Tamworth NSW 2340	Base
Toronto Triggs Motors (049- 59 2122) 36 Victory Parade Toronto NSW 2283	Base
Wagga Wagga Jupiter Motors Pty Ltd (069- 21 6555) 20 Edward Strteet Wagga Wagga NSW 2650	Field
Wauchope Wauchope Motors (065- 85 3766) High Street Wauchope NSW 2446	Field
Victoria (3 MD)	
Ballarat Gordon Motors Pty Ltd (053- 39 5022) 1041-1043 Howitt Street Wendouree VIC 3355	Base
Bendigo Provincial Motors Div. of Ansett Transport — Operations (054- 48 4433) Midland Highway, Epsom Bendigo VIC 3551	Field

Table 2-2 Land Rover dealers (cont'd)

Agent	Repair Level
Brighton Lane Jaguar Rover Pty Ltd (03- 557 2875) 771 Nepean Highway Brighton VIC 3187	Base
Corryong Mildren and Coysh Pty Ltd (060- 76 1151) Cnr Anzac and Towong Roads Corryong VIC 3707	Field
Frankston Steward Webster (03- 781 2022) 130 Dandenong Road Frankston VIC 3199	Base
Geelong Peck and Stokes Motors (052- 21 2111) 31-37 Gordon Avenue Geelong VIC 3218	Unit
Malvern ULR Sales and Service (03- 822 0211) 1339 High Street Malvern VIC 3144	Base
Mansfield Berry and O'Halloran (057- 75 2375) 121-123 High Street Mansfield VIC 3722	Field
Melbourne Manton Rover (03-266 2501) 666 Elizabeth Street Melbourne VIC 3051	Base
Mildura Syd Mills Motors Pty Ltd (050- 23 0261) 19-29 Orange Avenue Mildura VIC 3500	Field

Table 2-2 Land Rover dealers (cont'd)

Agent	Repair Level
Morwell Massaro Motors Pty Ltd (051- 34 1422) 497 Princes Highway Morwell VIC 3840	Field
Nunawading Whitehorse Motors (03- 878 6677) 296 Whitehorse Road Nunawading VIC 3131	Base
South Australia (4 MD)	
Bordertown Inglis Motors (087- 52 1577) South Terrace Bordertown SA 5268	Field
Hawthorn Solitaire Motors (08-272 8155) 26 Belair Road Hawthorn SA 5062	Base
Millicent Alex Bohner Motors Pty Ltd (087- 33 2022) 44 Mount Gambier Road Millicent SA 5280	Base
Walkerville Prestige Cars (08-269 2922) 130-134 North East Road Walkerville SA 5081	Base
Western Australia (5 MD)	
Broome Shinju Motors (091-92 1250) Walcott Street Broome WA 6725	Field

Table 2-2 Land Rover dealers (cont'd)

Agent	Repair Level
Bunbury Wallace Motors Pty Ltd (097- 21 4588) 72 Spencer Street Bunbury WA 6230	Base
Carnarvon Dellbar Motors (099- 41 1397) 60 Robinson Street Carnarvon WA 6701	Field
Derby Kimwest Motors (091- 91 1647) 44 Clarendon Street Derby WA 6728	Field
Esperance Ratten and Slater (090- 71 0133) Cnr Norseman and Sheldon Road Esperance WA 6450	Field
Katanning P. L. Bolto and Co. (098- 21 1566) 71 Clive Street Katanning WA 6317	Field
Kununurra Norwest Diesel Service (091- 68 1195) Bloodwood Drive Kununurra WA 6743	Field
Manjimup Manjimup All Wheel Drive (097- 71 1535) Franklin Street Manjimup WA 6258	Field
Perth Winterfaulls Pty Ltd (09- 328 9333) 252 Aberdeen Street Perth WA 6000	Base

Table 2-2 Land Rover dealers (cont'd)

Agent	Repair Level
South Hedland N and L Mechanical (091-72 2623) Lot 3780 Carlindie Way Wedgefield South Hedland WA 6722	Field
Wyndham Branco BP Motors (091- 61 1305) Great Northern Highway Wyndham WA 6740	Unit
Tasmania (6 MD)	
Hobart Terry Hickey Autos Pty Ltd (002- 34 91220) 167-171 Murray Street Hobart TAS 7000	Base
Launceston Davies Car Centre (003- 31 9422) Cnr. Wellington and Frederick Streets Launceston TAS 7250	Base
Northern Territory (7 MD)	
Alice Springs Sutton Motors (089- 52 1334) 13 Smith Street Alice Springs NT 5750	Field
Darwin Port Darwin Motors Pty Ltd (089- 81 9444) 15 Stuart Highway Darwin NT 5790	Base

Table 2-2 Land Rover dealers (cont'd)

Agent	Repair Level
Katherine Agserv industries (089- 72 1788) 441 Victoria Highway Katherine NT 5780	Unit
Australian Capital Territory	
National Capital Motors (062-51 2600) Josephson Street Belconnen ACT 2617	Base

SECTION 2

VEHICLE OPERATION

216. General

Proper operation determines the service life and operating economy of the vehicle. This includes, careful driving, normal road speeds, reasonable rates of acceleration and braking and changing gears in a manner to avoid shock loading and labouring.

217. Before starting

Carry out a first parade service as detailed in Chapter 3 Section 1.

218. Before starting the engine

Ensure that the parking brake is applied. Depress the clutch pedal fully to disengage the clutch then move the gear lever to neutral.

219. Starting the engine

CAUTION

Do not accelerate the engine immediately after starting, otherwise damage to the turbocharger will result through lack of lubrication.

NOTE

The glow plugs need only be used to start the engine when the vehicle is operating continually in low ambient temperatures (below 5°C), and then for no longer than five seconds.

Depress the accelerator pedal approximately half way and hold the pedal in this position while turning the ignition switch clockwise to start the engine. As the switch is turned to the first position (see Fig. 2-1), the oil pressure, battery charge and parking brake warning lights will illuminate. In the next switch position the glow plug light illuminates, but do not hold the switch in this position unless cold operating conditions are experienced. Turn the switch fully to engage the starter motor, then release the switch and return the accelerator pedal to the idle position once the engine has started. All warning lights except the parking brake light should now be extinguished.

NOTE

Do not operate the starter motor continuously for longer than ten seconds without a pause.

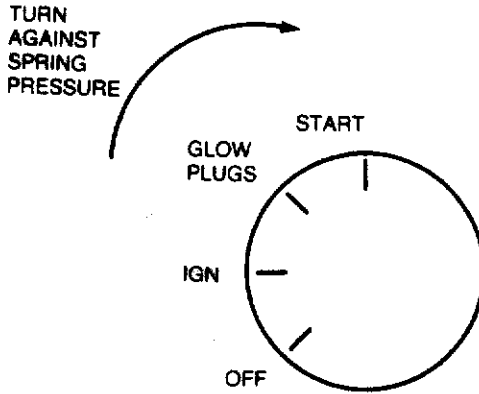

Figure 2-1 Starter switch positions

220. Moving the vehicle

- a. With the engine operating, disengage the clutch by pushing the pedal to the floor. Select high ratio or low ratio on the transfer case shift lever, depending on the vehicle load and terrain.

NOTE

Changing from high to low or low to high ratio should only be attempted when the vehicle is stationary. Should difficulty be encountered when engaging high or low ratio, do not force the lever. With the engine running, engage a gear with the main gear lever and release the clutch momentarily, then return the main gear lever to neutral and try the transfer case shift lever again.

- b. Select first gear on the gear lever then release the parking brake. If the parking brake warning light does not extinguish, do not attempt to move the vehicle.

- c. Engage the clutch smoothly by releasing the clutch pedal and simultaneously depressing the accelerator pedal the amount necessary for the engine to move the load.

NOTE

Never allow the foot to RIDE the clutch pedal with the clutch engaged. This causes premature clutch wear.

- d. As the vehicle gains speed, continue changing gear until cruising speed is achieved and the transmission is in the highest gear possible without labouring the engine.

Good driving habits

221. Engine temperature

Allow the engine to reach normal operating temperature before engaging in high speeds or hauling heavy loads.

WARNING

Should the engine become overheated, park the vehicle in a safe working area and allow the engine to cool before attempting repairs to, or refilling of, the cooling system.

222. Instruments

Glance at the instruments frequently. If a fault is indicated, assess the corrective action required and stop the vehicle as necessary.

223. Clutch

To avoid damage, engage the clutch with a smooth action. Do not RIDE the clutch.

224. Gear changing

Ensure that the correct gear is selected for the terrain, vehicle load and speed.

225. Braking

Avoid sudden stops. When stopping on slippery surfaces, smoothly apply and release the brakes alternately, to prevent skidding. When slowing to a halt, leave the clutch engaged as long as possible to utilize the engine braking effect. Before descending steep slopes, select first gear, low ratio with the differential locked to provide maximum engine braking.

226. Stopping the engine

CAUTION

Before shutting down the engine, allow the engine to idle for several minutes to allow the turbocharger temperature to stabilize and the rotational speed of the turbine to slow down, otherwise damage to the turbocharger will result through lack of lubrication.

Allow the engine to return to the normal idle speed before turning the ignition off.

227. Parking

Use the parking brake when parking the vehicle. Check frequently to ensure that the brake is adjusted to lock and hold the vehicle when parked. Do not use the parking brake when the vehicle is in motion, except in an emergency. When parking on an incline, leave the vehicle in gear.

228. Fording

The maximum advisable fording depth is 500 mm. When fording is to be undertaken, ensure that the flywheel housing drain plug is securely fitted (see Fig. 2-2). If deep water is anticipated, loosen the fanbelt to prevent damage to the fan or radiator, and saturation of the electrical system. Avoid excessive speed.

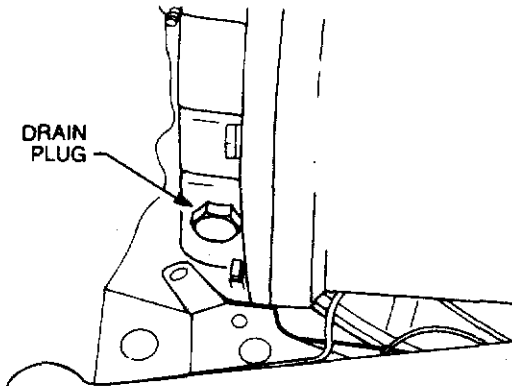

Figure 2-2 Flywheel housing drain

229. Once the crossing has been accomplished, drain the flywheel housing and tighten the fanbelt. Ensure that the brakes are dry and fully effective before proceeding.

NOTE

After fording, check the oil in the engine, transmission, transfer case and swivel pin housing for signs of water contamination. Change contaminated oils as soon as possible.

230. Cross-country driving

WARNING

Because of the excellent rough terrain characteristics of this vehicle, drivers are cautioned to maintain a safe speed for the conditions encountered, **especially when towing a trailer or utilizing tyre chains.**

NOTE

The mobility of this vehicle is greatly enhanced if correct tyre pressures are maintained, and in extreme conditions, tyre chains are used.

The transfer case differential lock should be utilized for cross-country driving, ie. off formed roads and tracks. When activated, the differential lock warning light will illuminate indicating that the dog clutch in the transfer case is fully engaged. Although the differential lock can be engaged while the vehicle is moving, no power should be applied to the transmission during this operation.

NOTE

Under some conditions, a slight delay may be experienced before the warning light illuminates. This is due to the time required for the dog clutch to align with its mating splines and become fully engaged.

231. On reaching normal road conditions, the differential lock must be disengaged.

NOTE

Under some conditions, a slight delay may be experienced before the warning light extinguishes after the switch is pushed in. If the warning light does not extinguish, this indicates that the dog clutch is not fully disengaged. This is usually due to transmission wind-up which jams the dog clutch. If the warning light does not extinguish within 100 metres of the switch being pushed in, the vehicle should be stopped and reversed a few metres to unwind the transmission. The warning light should now extinguish. If not, do not continue as serious damage may occur.

Changing a wheel

232. To replace a flat tyre with the spare wheel, proceed as follows:
- a. Remove the hydraulic jack, handle and jack base plate, from the stowage bin.
 - b. Engage the differential lock and check that the differential lock warning light illuminates.

NOTE

If the vehicle has been stationary prior to changing the wheel, the differential lock may not engage when selected. In this case, it will be necessary to start the engine, engage a gear and release the clutch sufficiently to allow slight movement of the gears, until the warning light is illuminated. Switch off the engine.

- c. Ensure that the parking brake is applied and that the wheels are chocked.

WARNING

The parking brake acts on the transmission, not the rear wheels. The differential lock must be engaged and the wheels chocked to enable the vehicle to be raised safely.

- d. Engage first gear in the transmission and low range in the transfer case.
- e. Position the jack under the vehicle as follows:
 - (1) Front wheel. Position the jack so that when raised, it will engage with the front axle casing immediately below the coil spring, where it will locate between the flange at the end of the axle casing and the large bracket to which the front suspension members are mounted (see Fig. 2-3).

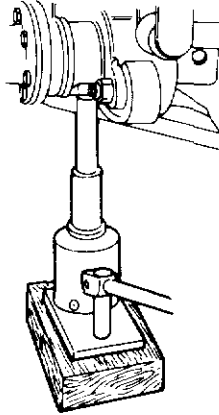

Figure 2-3 Jack position — front wheels

- (2) Rear wheel. Position the jack so that when raised, it will contact the axle tube between the spring and the shock absorber bracket (see Fig. 2-4).

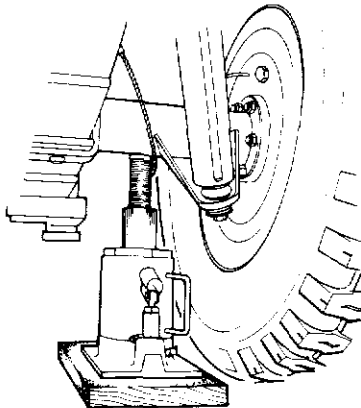

Figure 2-4 Jack position — rear wheels

- f. Before raising the vehicle, lower the spare wheel to the ground and remove it from under the vehicle, then using the wheel brace, initially slacken the nuts on the wheel to be removed.
- g. Jack up the appropriate corner of the vehicle. When the wheel is clear of the ground, remove the wheel nuts and lift off the wheel.
- h. Ensure that the wheel nuts and studs are clean then fit the spare wheel and secure with the wheel nuts. Tighten the wheel nuts.
- i. Lower the vehicle to the ground and torque the wheel nuts to 100-115 Nm (75-85 lb.ft) in the correct sequence (diagonally opposite). Use hand pressure only. Do not use foot pressure or extension tubes as this could overstress the wheel studs.
- j. Remove the jack and the wheel chocks then disengage the differential lock.

Towing

233. The following precautions must be taken before towing:

- a. Set the transmission and transfer case to neutral.
- b. Set the transfer case control switch to the on-road position.
- c. Ensure that the differential lock warning light is extinguished. If the warning light fails to extinguish, both the front and rear propeller shafts are to be removed.
- d. When the front propeller shaft is to be removed, the flange mounting bolts must be secured with nuts or wire to prevent damage to the transmission casing.

Canopy bow stowage

234. To stow the canopy bow, proceed as follows:

- a. Remove the nuts, washers and bolts that retain the bow support to the canopy bows, then remove the support. Using the same procedure, remove the opposite bow support and central walkway.
- b. Remove the R-clips and pins securing the rear canopy bow to the cargo tray then, remove the canopy bow.
- c. Dummy sockets have been provided for stowing the rear canopy bow forward of the front canopy bow (see Fig. 2-5).

- d. Ensure that the canopy bow is secured by the pins provided when in the stowed position.

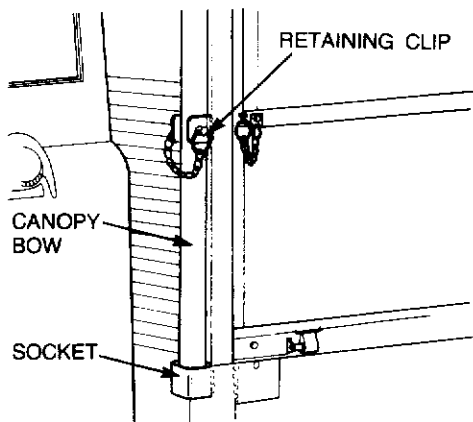

Figure 2-5 Canopy bow dummy socket

Canopy

235. To fit a canopy to the vehicle, proceed as follows:

- a. Roll the canopy back over the frame and align the canopy with the cargo tray.
- b. Starting at the front, tighten all the straps securing the canopy to the bow support frames (see Fig. 2-6).

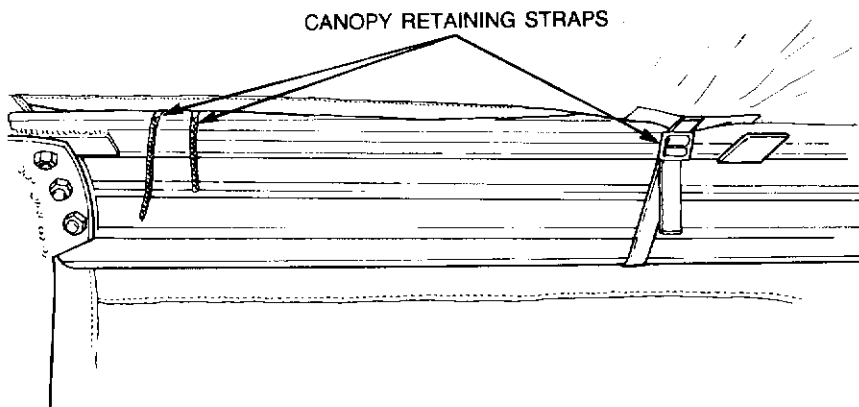

Figure 2-6 Canopy retaining straps

- c. Secure the lower edge of the canopy to the body sides then, pull the canopy around the rear canopy bow and tie the ropes to the rear cargo tray tie hooks.

Rear seat stowage

- 236. To stow the rear seat, proceed as follows:
 - a. Raise the seat to the side and engage the spring loaded index pin in the centre support leg (see Fig. 2-7).
 - b. Release the three R-clips and pins securing the seat frame assembly to the body sides, then remove the seat frame assembly from the cargo tray.

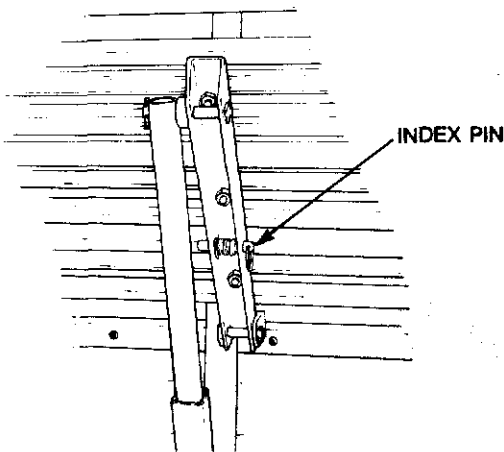

Figure 2-7 Rear seat stowage



CHAPTER 3

OPERATOR SERVICING

SECTION 1 — SERVICING

SECTION 2 — LUBRICATION

SECTION 1

SERVICING

First parade servicing

301. Before moving off with a loaded or unloaded vehicle, carry out the inspections, checks and tests as laid down in this section. Inspect for damage, security and serviceability.

302. Check the wheels and tyres for the following:

- a. Loose wheel nuts.
- b. Correct tyre pressure (see page 77).
- c. Cuts, weak spots, uneven wear, exposed cords, or clogged tyres.

303. Check the following fittings:

- a. All cabin and body fittings.
- b. Spare wheel.
- c. Stowage space, doors and lids.
- d. Windscreen, driving mirrors, door windows, hinges, catches and latches for security.
- e. Check light lenses, driving mirrors and windscreens and clean.
- f. Tow hook, coupling and security.

304. Check the stowed items as follows:

- a. Completeness of equipment and correct stowage.
- b. For loose items in cabin or tray.
- c. De-ditching tools.
- d. Fire extinguisher, fully charged and correctly stowed.

305. Check the fuel, lubricants and coolant as follows:

- a. Fuel level in tank. Replenish as necessary.
- b. Check jerrican and refill if necessary.
- c. Engine oil level using dipstick. Top-up as necessary.
- d. Coolant level in radiator expansion tank. Top-up if necessary.
- e. Water can in stowage. Top-up if necessary.
- f. For fuel, lubricant and coolant leaks. Examine major assemblies and the ground below the vehicle for evidence.

Start the vehicle

306. Start the vehicle as detailed in Chapter 2 Section 2 and check the following:

- | | | |
|----|---------------------------|--|
| a. | Voltmeter | Any irregular readings indicates battery or charging system requires checking. |
| b. | Horn | Check operation of the horn. |
| c. | Lights | Check operation of all lights. |
| d. | Windshield wipers/washers | Check operation. Add water, if needed. |
| e. | Parking brake | Check release, holding ability and application. |
| f. | Clutch pedal | Check for free travel. |
| g. | Seat adjustment | Ensure that seat is correctly adjusted. |

Electrical

307. Check the following:

- | | | |
|----|---------|---|
| a. | Battery | Check electrolyte level — fill to 10 mm above plates. Check that the terminals are clean and tight. |
| b. | Lights | Switch off all lights not required. |

Moving off and running

308. Check the following:

- Load — make a final check of the security of load and lashings, if applicable.
- Moving off — Release the parking brake. DO NOT move off if the parking brake warning light remains illuminated. Check correct operation of steering and brakes.
- Keep a running check on all instruments.
- Check the fuel level, coolant temperature, warning lights, charging rate and speedometer at intervals.

Halts on the march

309. At halts on the march check that:

- The cargo and lashings are secure.
- No tyre is soft, punctured or overheated.
- Wheel hubs or brake drums are not overheated.
- There are no oil, fuel or coolant leaks.

310. At halts or after approximately four hours running:

- a. Check tyre pressures. If low, inflate. (If high, check later when tyres are cold, before deflating).
- b. Ensure that all wheel nuts are secure.
- c. Test all lights (especially if there is a possibility that they will be required).
- d. Check generally for loose bolts or fittings. Tighten as necessary.
- e. Ensure security of stowed items.
- f. Inspect for security and correct operation any parts on which recent repairs or adjustments have been carried out.

Last parade servicing

311. Carry out the following:

- a. Clean the vehicle.
- b. Carry out "halt on the march" servicing.
- c. Draw fuel and lubricants, as required and top-up fuel tank, engine oil and radiator expansion tank coolant. If operating under very dusty conditions, the air cleaner should be removed and cleaned.
- d. If vehicle has been subjected to deep water crossings during daily exercise, the oil in the swivel pin housings, front, intermediate and rear axles, transmission and transfer case, should be checked for signs of water contamination. If any traces of water are found, the oil should be drained and replenished with correct type as soon as possible.
- e. Check radiator core for insects, mud, etc., clean as required with compressed air or water.
- f. Complete documentation.
- g. Close the doors and windows and lace up canopy flaps.

Opening bonnet for servicing access

312. To open the bonnet, proceed as follows:

- a. Pull the bonnet release handle.
- b. Release the safety catch at the front of the bonnet.
- c. Lift the bonnet up and pull the support stay forward.

WARNING

Ensure that the bonnet support stay is properly locked before releasing the bonnet.

313. To close the bonnet, proceed as follows:

- a. Hold the bonnet open and push the support stay back.
- b. Gently lower the bonnet then push the bonnet down firmly to lock in position. Do not allow the bonnet to drop from the open position.

Radiator coolant

314. Normal cooling system replenishment is via the expansion tank. However, in the event of excessive coolant loss or drainage, the following radiator filling procedure is to be adopted.

- a. Remove the expansion tank pressure cap and move the heater controls to the highest temperature position.
- b. Remove the brass filler plug from the thermostat housing (see Fig. 3-1).
- c. Using coolant with a mixture concentration of 5% Alfloc 2001, top-up the system through the filler hole, then replace the plug.
- d. With the pressure cap removed, run the engine for a minimum of two minutes.
- e. Stop the engine and remove the plug from the thermostat housing. Top-up as required, then install and tighten the plug securely.
- f. Fill the expansion tank to the correct level and install the cap.
- g. Run the engine and check for leaks.

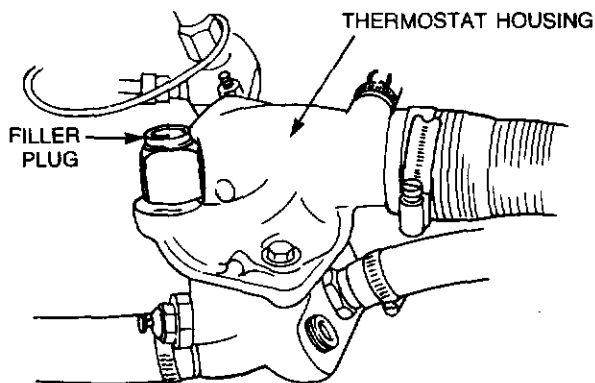

Figure 3-1 Thermostat housing

Bleeding the fuel system

315. To bleed the fuel system, proceed as follows:
- Loosen the screw cap on the transfer pump and operate the primer.
 - Loosen the overflow valve on the fuel filter adapter (see Fig 3-2) and continue operating the primer until a solid stream of fuel flows from the valve.
 - Tighten the overflow valve and continue operating the primer. Loosen the air bleed screw on the fuel injection pump and continue operating the primer until a solid stream of fuel flows from the air bleed screw. Tighten the air bleed screw.
 - Secure the primer screw cap and start the engine. Ensure that the engine runs smoothly.

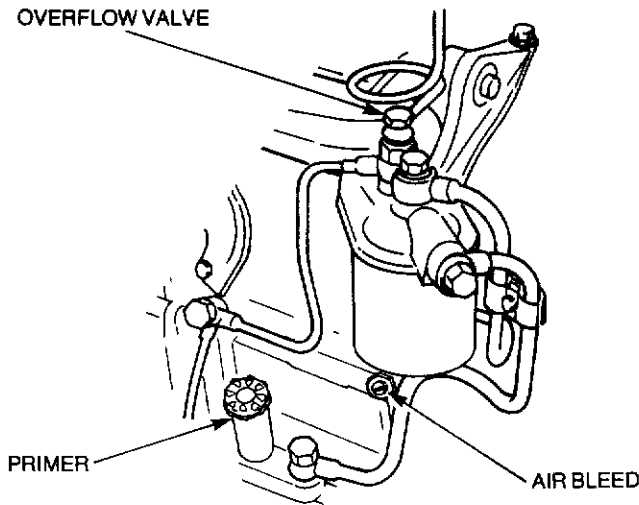

Figure 3-2 Bleeding the fuel system

316. Periodical maintenance

- To ensure that the vehicle is correctly maintained and prepared for operational tasks, it is necessary to carry out regular maintenance.
- Daily and Fortnightly Servicing in accordance with Tables 3-1 and 3-2 is to be carried out by operators and is the responsibility of owner units.
- Initial service should be carried out after the vehicle has

been in service for a period of three months, or having travelled 1600 km, whichever occurs first. The service is the responsibility of JRA Limited and will be carried out by arrangement with any Land Rover franchised Dealer at no charge to the Army, except for the cost of replacement lubricants and filters. Alternatively this service can be carried out by an Army tradesman in accordance with Table 3-3, should it not be convenient for the vehicle to be returned to the authorised Land Rover Dealer at that time.

- d. Minor and major Servicing is to be carried out by RAEME with assistance from operators working under RAEME supervision in accordance with Tables 3-4 and 3-5. The unit is responsible for ensuring that the vehicle is serviced at the following intervals.
- (1) **Minor Service.** This is to be carried out every six months or 10 000 km of operation, whichever occurs first.
 - (2) **Major Service.** This is to be carried out every twelve months or 20 000 km of operation, whichever occurs first.

Special requirements

317. During the early life of a vehicle the working parts settle down, with the result that various clearances and adjustments need to be corrected. Operators should report problems for rectification at the earliest opportunity.

318. The Initial Service includes a warranty inspection which must be reported to Land Rover Australia in accordance with EMEI VEHICLE A 119-22.

Table 3-1 Daily tasks

The following operations are to be performed by the driver:

1. Check engine oil level (top-up if necessary).
2. Check coolant level (top-up if necessary).
3. Check power steering reservoir (top-up if necessary).
4. Check tyres and wheels. Inflate tyres if necessary, inspect wheel nuts for evidence of looseness.
5. Check for fuel, oil and coolant leaks.

Table 3-1 Daily tasks (cont'd)

6. Check fuel supply and operation of fuel gauge.
7. Check voltmeter reading. With switch on and engine off, indicates battery condition. With engine running, reading indicates condition of charging system.
8. Check operation of horn.
9. Check all lights for correct operation and report any defects.
10. Check operation of footbrake, parking brake and clutch.
11. Check coolant temperature gauge reading.
12. Check operation of windscreen wipers and washers, top-up washer reservoir if required.
13. Check air cleaner restriction gauge reading. If locked in "red" position, the air cleaner elements must be changed. Under dusty conditions, remove and clean elements.
14. Check seats and seat belts for operation and security.
15. Check driving mirrors, door windows, catches and latches.

Table 3-2 Fortnightly tasks

The following operations are to be performed by the driver:

1. Check condition and tension of fanbelt. Approx. 10-15 mm deflection on longest span using moderate thumb pressure.
2. Battery. Check level of electrolyte, top-up if necessary, examine terminals for cleanliness and security. Check for leaks and security, clean outside of battery if required.
3. Check radiator external condition for restriction, clean if required.
4. If operating in dusty conditions, remove air cleaner elements and clean.
5. Check operation of hand throttle and stop control.
6. Check operation of differential lock control.
7. Check operation of transfer case control.
8. Check condition of wheel rims, tyres and valve stems.
9. Check wheel nuts are torqued correctly.

Table 3-2 Fortnightly tasks (cont'd)

10. Check operation and security of spare wheel carrier.
11. Check security of fuel tanks and lines.
12. Check fuel, oil and coolant systems for leaks.
13. Drain water from sedimenters.

Table 3-3 Initial servicing

The following operations are to be performed by the driver under supervision:

1. Start and warm up the engine.
2. Stop the engine, drain engine oil and refill.
3. Remove and replace oil filters.
4. Drain and refill transmission.
5. Drain and refill transfer case.
6. Drain and refill front axle.
7. Drain and refill intermediate axle.
8. Drain and refill rear axle.
9. Drain and refill swivel pin housings.
10. Lubricate propeller shafts.
11. Lubricate pintle hook.
12. Check battery electrolyte level (10 mm above plates) and security of terminals.
13. Check all fuel and oil lines and unions for leaks.
14. Retorque all wheel nuts to correct specifications.
15. Check tyres and wheels, inflate if necessary. Inspect rims for damage.
16. Check operation of all lights and gauges.
17. Check for loose electrical connections.
18. Check operation of foot brake, parking brake and clutch.
19. Check exhaust systems for leaks, damage and security.

Table 3-3 Initial servicing (cont'd)

The following operations are to be performed by a Qualified Vehicle Mechanic:

20. Retorque inlet and exhaust manifolds.
21. Check and adjust fanbelt tension. Retorque alternator mounting bolts.
22. Check torque of radiator mounting bolts, tighten as required.
23. Tighten all propeller shaft coupling drive bolts.
24. Replace primary fuel filter and bleed system.
25. Road Test. Carry out a road test on steering and brake system. Note all faults and rectify as necessary.

Table 3-4 Minor servicing

The following operations are to be performed by the driver under supervision:

1. Start and warm up engine.
2. Stop engine, drain engine oil and refill.
3. Remove and replace oil filters.
4. Check condition of engine mountings.
5. Check engine hand throttle and stop control for connections and operation.
6. Check all lights and gauges for correct operation, report defects.
7. Check condition of radiator shroud and fins. Clean fins as necessary.
8. Retorque radiator hose connections.
9. Check operation of footbrake, parking brake and clutch.
10. Check operation of windscreen wipers and washers.
11. Check condition of windscreen wiper blades.
12. Check battery electrolyte level (10 mm above plates) and security of terminals. Check battery for cleanliness and security.
13. Check for oil, fuel and coolant leaks. Report any defects.

Table 3-4 Minor servicing (cont'd)

14. Check tyres and wheels, inflate if necessary. Inspect rims for damage.
15. Drain fuel sedimenters.
16. Drain flywheel housing.
17. Check air cleaner, remove, clean and install. If indicator shows "red" replace elements.
18. Check exhaust system for leaks, damage and security.
19. Check front shock absorbers for leaks, damage and security.
20. Inspect front and rear springs for damage.
21. Check oil level in front axle, top-up if necessary.
22. Check oil level in intermediate axle, top-up if necessary.
23. Check oil level in rear axle, top-up if necessary.
24. Check oil level in transmission, top-up if necessary.
25. Check oil level in transfer case, Top-up if necessary.
26. Check oil level in swivel pin housings, top-up if necessary.
27. Check brake, fuel and clutch pipes for chafing, leaks or corrosion.
28. Check condition of fanbelt.
29. Check radiator coolant, top-up if necessary.
30. Check brake servo hose for security and condition.
31. Check steering damper for leaks.
32. Check brake fluid reservoir, top-up if necessary.
33. Check clutch fluid reservoir, top-up if necessary.
34. Lubricate pintle hook.
35. Lubricate parking brake mechanical linkage.
36. Lubricate accelerator control linkage and pedal pivot.
37. Lubricate water pump.
38. Lubricate all hinges and mirror arms.
39. Lubricate propeller shafts.
40. Check operation of spare wheel carrier.

Table 3-4 Minor servicing (cont'd)

41. Check security of additional equipment.
42. Check driving mirrors, door windows, hinges, catches and latches.

The following operations are to be performed by a Qualified Vehicle Mechanic:

43. Inspect front brake pads for wear, calipers for leaks and the condition of the discs.
44. Inspect the rear brake linings and drums for wear.
45. Inspect wheel cylinders for fluid leaks.
46. Adjust rear brakes.
47. Adjust parking brake.
48. Check condition and security of steering unit, joints and boots.
49. Clean fuel pump strainer.
50. Check and adjust fanbelt if necessary.
51. Check and adjust engine idle.
52. Check and adjust steering box.
53. Check and adjust headlights.
54. Check front wheel alignment.
- *55. Drain and refill cooling system.

* Coolant to be changed at 10 000 km, then every two years.

Table 3-5 Major servicing

The following operations are to be performed by the driver under supervision:

1. Start and warm up engine.
2. Stop engine, drain engine oil and refill.
3. Remove and replace oil filters.
4. Check condition of engine mountings.
5. Check engine hand throttle and stop control for connections and operation.

Table 3-5 Major servicing (cont'd)

6. Check all lights and gauges for correct operation, report defects.
7. Check condition of radiator shroud and fins. Clean fins as necessary.
8. Retorque radiator hose connections.
9. Check operation of foot brake, hand brake and clutch.
10. Check operation of windscreen wipers and washers.
11. Check condition of windscreen wiper blades.
12. Check battery electrolyte level (10 mm above plates) and security of terminals. Check for cleanliness and security.
13. Check for oil, fuel and coolant leaks. Report any defects.
14. Check tyres and wheels, inflate if necessary. Inspect rims for damage.
15. Drain fuel sedimenters.
16. Check air cleaners, remove, clean, and install. Fit new elements if indicators show "red".
17. Check exhaust system for leaks, damage and security.
18. Check front shock absorbers for leaks, damage and security.
19. Check front and rear springs for damage.
- *20. Drain and refill front axle.
- *21. Drain and refill intermediate axle.
- *22. Drain and refill rear axle.
- *23. Drain and refill swivel pin housings.
- *24. Drain and refill transmission.
- *25. Drain and refill transfer case.
26. Check brake, fuel and clutch pipes for chafing, leaks or corrosion.
27. Check condition of fanbelt.
28. Check radiator coolant, top-up if necessary.
29. Check brake servo hose for security and condition.
30. Check steering damper for leaks.

Table 3-5 Major servicing (cont'd)

31. Check steering reservoir level, top-up if necessary.
32. Check brake fluid reservoir, top-up if necessary.
- *33. Renew brake servo filter.
34. Check clutch fluid reservoir, top-up if necessary.
35. Lubricate pintle hook.
36. Lubricate parking brake mechanical linkage.
37. Lubricate accelerator control linkage and pedal pivot.
38. Lubricate water pump.
39. Lubricate all hinges.
40. Lubricate propeller shafts.
41. Check propeller shaft coupling bolts.
42. Check operation of spare wheel carrier.
43. Check security of additional equipment.
44. Check driving mirrors, door windows, hinges, catches and latches.
* Every second major service (40 000 km).

The following operations are to be performed by a Qualified Vehicle Mechanic:

45. Inspect front brake pads for wear, calipers for leaks and the condition of the discs.
46. Inspect the rear brake linings and drums for wear.
47. Inspect wheel cylinders for fluid leaks.
48. Adjust rear brakes.
49. Adjust parking brake.
50. Check condition and security of steering unit, joints and boots.
51. Clean fuel pump strainer.
52. Check and adjust fanbelts, if necessary.
53. Clean and spray test fuel injectors.
54. Clean and test glow plugs.

Table 3-5 Major servicing (cont'd)

55. Check engine compression.
56. Clean engine breather filter.
57. Check and adjust engine idle.
58. Check and adjust steering box.
59. Check front wheel alignment.

Tyre pressure (cold)

Highway:

front	250 kPa (36 psi)
intermediate	350 kPa (50 psi)
rear	350 kPa (50 psi)

Cross-country:

front	200 kPa (29 psi)
intermediate	275 kPa (40 psi)
rear	275 kPa (40 psi)

Sand:

front	150 kPa (22 psi)
intermediate	225 kPa (33 psi)
rear	225 kPa (33 psi)

SECTION 2

LUBRICATION

319. Table 3-6 details the lubricants required for vehicle servicing. However, refer to EMEI VEH G 209 for the approved list of lubricants and servicing instructions.

Table 3-6 List of Lubricants

Equipment	Lubricant	Capacity (litres)
Engine (including filters)	OMD-115	8.5
Transmission	OMD-115	2.7
Transfer Case	Castrol FMX	3.2
Front Differential	OEP-220	1.7
Intermediate Differential	OEP-220	2.3
Rear Differential	OEP-220	2.7
Swivel Pin Housings	OEP-220	0.35 (each)
Brake Master Cylinder	OX (Aust) 8	Fill to level
Clutch Master Cylinder	OX (Aust) 8	Fill to level
Power Steering Reservoir	OX 46	1.25
Chassis Lubrication	XG-274	As required
Wheel Bearings	XG-274	As required

320. Fig. 3-3 illustrates the location of various lubrication and oil drainage/refill points around the vehicle.

NOTE

Run the engine or drive the vehicle as appropriate to warm oils before draining.

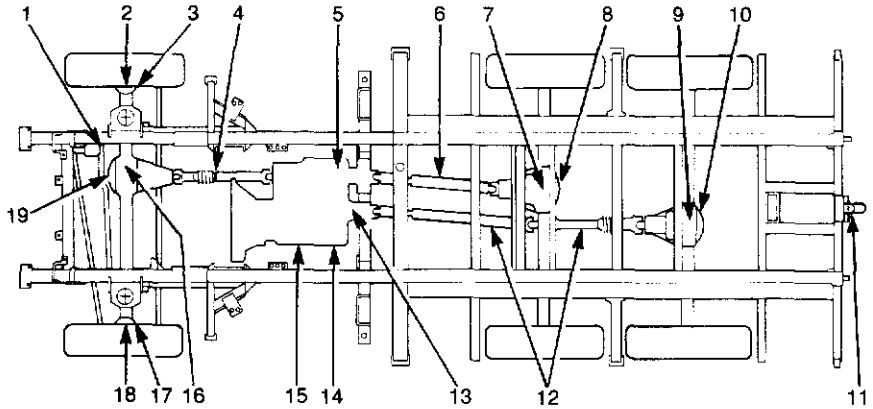

- | | |
|--|---|
| 1. Power steering reservoir | 11. Pintle |
| 2. Right hand swivel pin housing drain plug | 12. Rear propeller shaft |
| 3. Right hand swivel pin housing fill plug | 13. Transfer case fill plug |
| 4. Front propeller shaft grease nipples | 14. Transmission fill plug |
| 5. Transfer case drain plug | 15. Transmission drain plug |
| 6. Intermediate propeller shaft grease nipples | 16. Front axle drain plug |
| 7. Intermediate axle drain plug | 17. Left hand swivel pin housing fill plug |
| 8. Intermediate axle fill plug | 18. Left hand swivel pin housing drain plug |
| 9. Rear axle drain plug | 19. Front axle fill plug |
| 10. Rear axle fill plug | |

Figure 3-3 Lubrication and oil drain/refill points

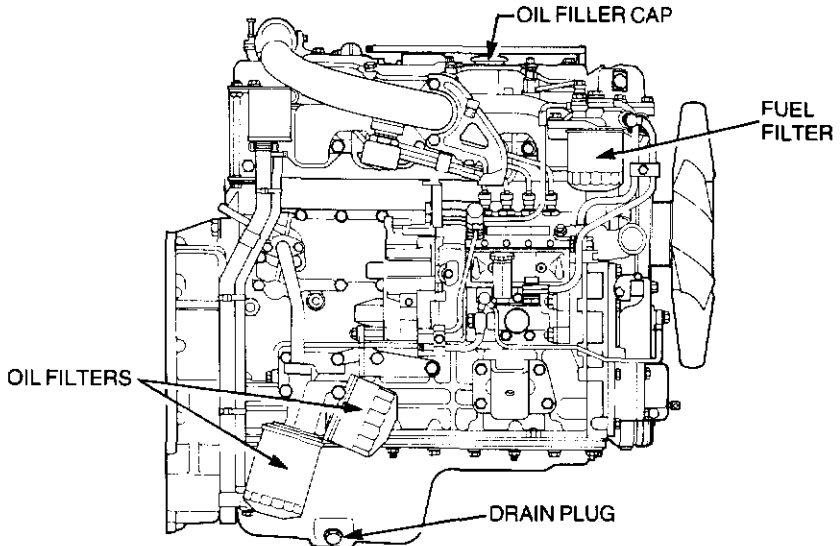

Figure 3-4 Engine — right hand side

Engine oil and oil filter change procedure

321. Run the engine until the engine coolant reaches normal operating temperature then shut down the engine. Remove the engine oil pan drain plug (see Fig. 3-4) and drain the oil into a suitable receptacle before the engine cools. Fit a new sealing washer on the drain plug and install the drain plug.

322. Unscrew each oil filter cartridge counter-clockwise, using a suitable oil filter removing tool if necessary (see Fig. 3-5). Apply a film of clean engine oil on the rubber seal of each new filter cartridge and install each filter. After the filter seal contacts the adapter, tighten the filter a further half a turn by hand only.

323. Fill the engine with the correct quantity of the recommended lubricant. Do not overfill. Check the level on the dipstick, then run the engine for about five minutes. Stop the engine and check the oil level on the dipstick. Add additional oil as required and check for leaks at the filters.

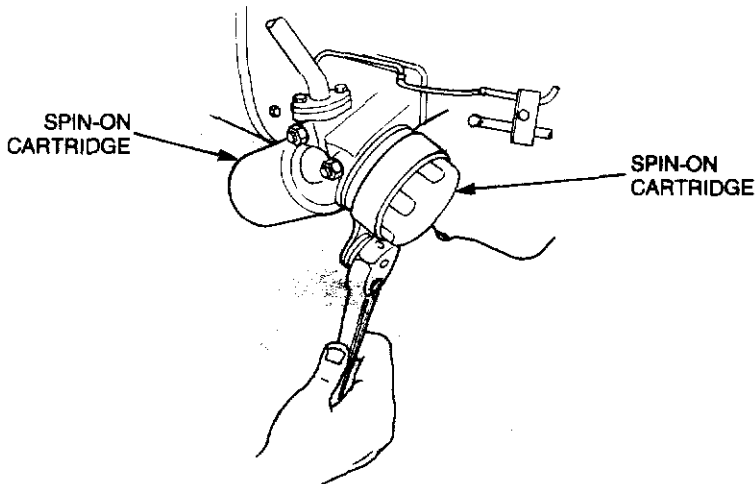

Figure 3-5 Oil filter removal

Transmission

324. The transmission drain plug is located on the left hand side of the transmission. Behind the drain plug is a filter which should be washed in clean fuel each time the transmission oil is drained. Allow the filter to dry completely before installing. Remove and wash the magnetic plug and remove all metallic particles. Install the plug.

325. The transmission fill plug is adjacent to the drain plug (see Fig. 3-6). Fill the transmission with the recommended lubricant to the bottom of the fill hole.

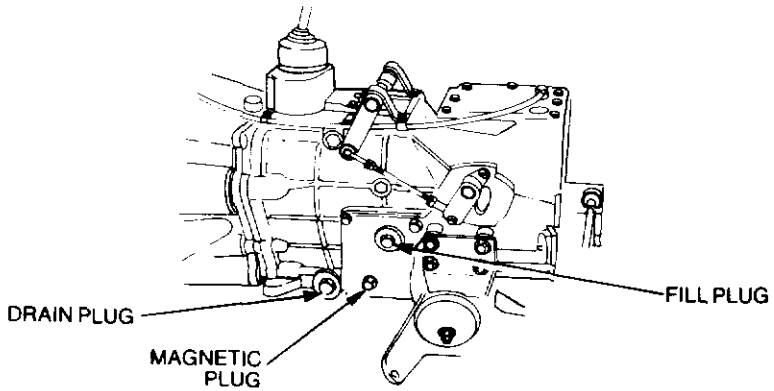

Figure 3-6 Transmission drain and fill plugs

Transfer case

326. The transfer case drain plug is located in the bottom of the transfer case (see Fig. 3-7). The plug should be cleaned each time the transfer case oil is drained. Use a new sealing washer on installation.

327. The transfer case fill plug is located on the rear of the housing (see Fig. 3-7). Fill the transfer case with the recommended lubricant to the bottom of the fill hole.

328. Ensure that the transfer case breather is not restricted.

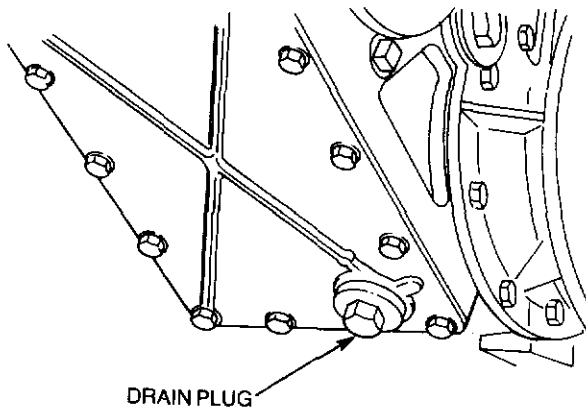

Figure 3-7 Transfer case drain and fill plugs

Intermediate axle

329. The drain plug is located on the bottom of the housing, while the fill plug is located on the rear cover (see Fig. 3-8). Fill the differential with the recommended lubricant to the bottom of the fill hole.

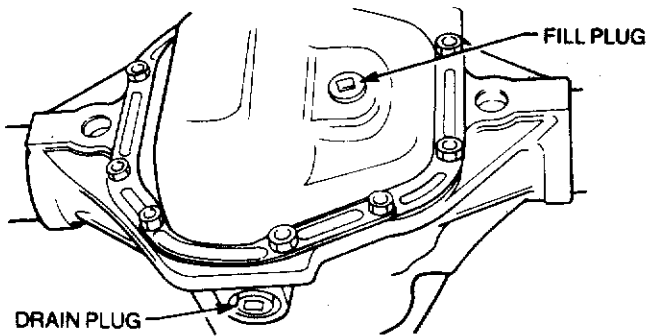

Figure 3-8 Intermediate axle drain and fill plugs

Rear axle

330. The drain plug is located on the bottom of the housing, while the fill plug is located on the rear cover (see Fig. 3-9). Fill the differential with the recommended lubricant to the bottom of the fill hole.

331. Ensure that the rear axle breather is not restricted.

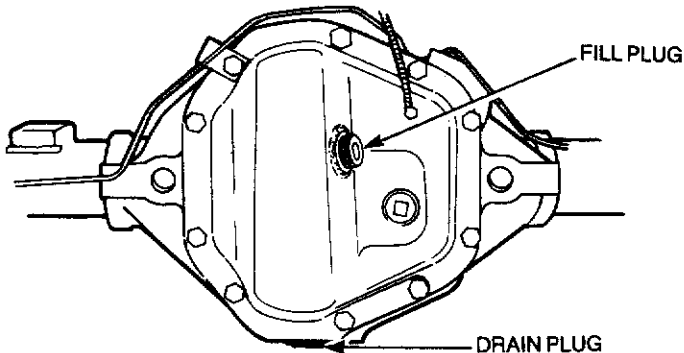

Figure 3-9 Rear axle drain and fill plugs

Front axle

332. The drain plug is located on the bottom of the housing, while the fill plug is located on the front of the housing. Fill the differential with the recommended lubricant to the bottom of the fill hole.

333. Ensure that the front axle breather is not restricted.

Steering reservoir/box

334. The steering reservoir/box are filled by removing the cap on top of the reservoir and filling the reservoir to the prescribed mark on the dipstick. No drain plug is fitted.

Swivel pin housings

335. The location of the drain plug and the fill plug is shown in Fig 3-10. To drain the swivel pin housing, remove both the fill and drain plugs and drain the oil into a suitable receptacle. Fill the swivel pin housing with the recommended lubricant to the bottom of the fill plug.

Propeller shafts

336. The propeller shafts are each fitted with a grease nipple (see Fig. 3-3 items 4 and 6) and lubrication is required each service.

Towing pintle

337. The towing pintle is fitted with one grease nipple and lubrication is required each service.

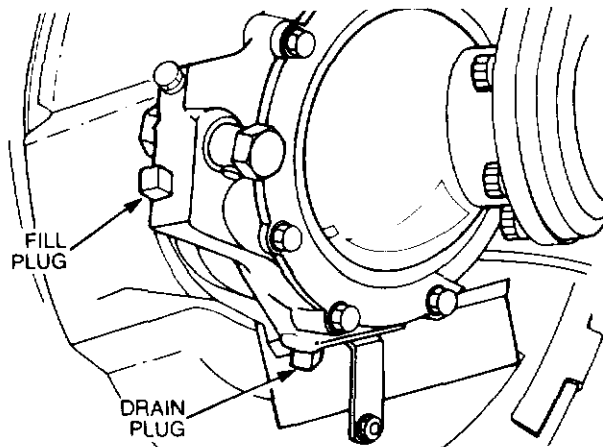

Figure 3-10 Swivel pin housing drain and fill plugs

Fuel filter

338. Place a suitable container beneath the fuel filter, then, using a suitable filter-removing tool, remove the filter (see Fig. 3-11). Remove the filter rubber seal from the cover. Smear clean fuel on the rubber seal of a new filter and install the new filter on the cover. Tighten the filter by hand until the rubber seal touches the cover face, then tighten a further half a turn. Bleed the fuel system as detailed in Chapter 3 Section 1.

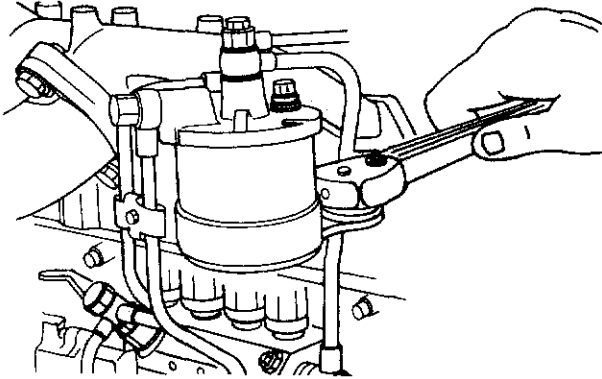

Figure 3-11 Fuel filter

Fuel sedimenters

339. Two fuel sedimenters, are located on the cabin rear crossmember forward of the rear spring mounting. A drain plug is fitted to allow the contents to be drained (see Fig. 3-12). Bleed the fuel system as detailed in Chapter 3 Section 1.

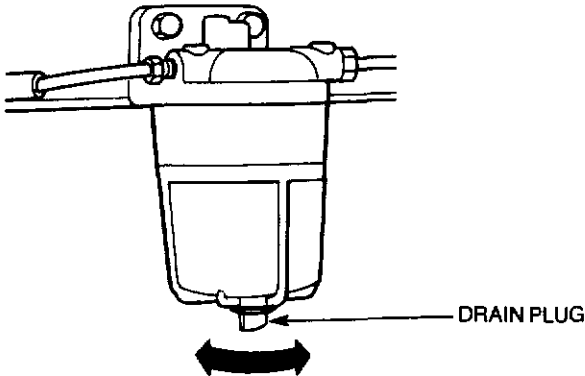

Figure 3-12 Fuel sedimenter

Air cleaner

340. The air cleaner elements will require cleaning or replacement when the signal indicator shows red. To clean or replace the air cleaner elements, proceed as follows:

- a. Remove the hose clamps securing the air inlet and outlet hoses to the air cleaner housing (see Fig. 3-13) then remove the two wing nuts from the clamp bolts. Carefully lift the air cleaner out of the mounting brackets.

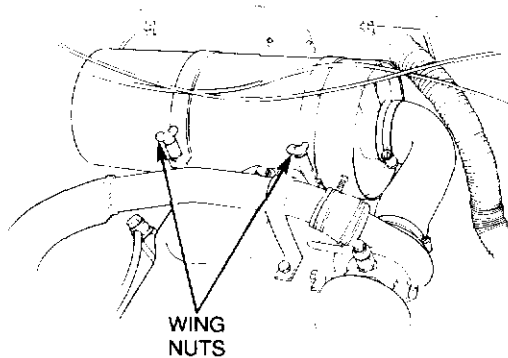

Figure 3-13 Air cleaner removal

- b. Remove the wing nuts securing the end cover and elements.
- c. Wipe out the air cleaner housing with a clean damp cloth. Remove and clean the dust valve (see Fig. 3-14).

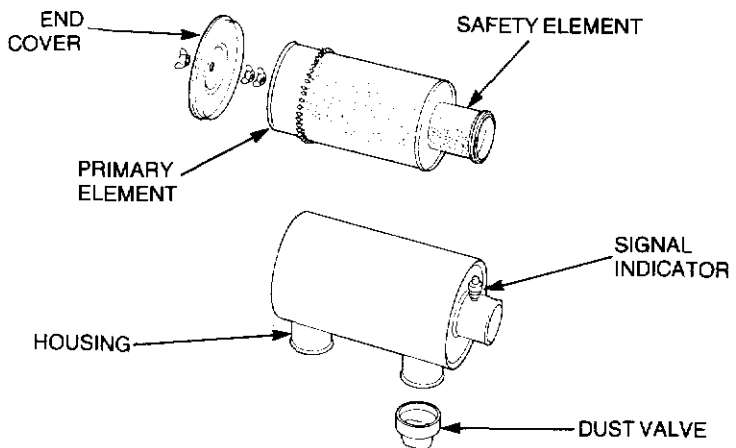

Figure 3-14 Air cleaner elements

- d. Clean or discard the primary element. If the element is to be cleaned, this can be achieved with compressed air or washing with a non-sudsing general purpose detergent (see EMEI VEH A 591-1). If washing, ensure that the element is dry before installing. Do not clean the safety element.
- e. Install and secure the new or cleaned element, then secure the end cover.
- f. Install the air cleaner assembly and connect the air inlet and outlet hoses. Secure the hose clamps and tighten the wing nuts.
- g. Depress the reset button on the signal indicator to enable the red signal to be released.

Brake reservoir

341. Check the fluid level in the brake reservoir against the level marked on the reservoir. If necessary, remove the reservoir top and top-up with clean brake fluid OX (Aust) 8. See Fig 3-15 for reservoir location.

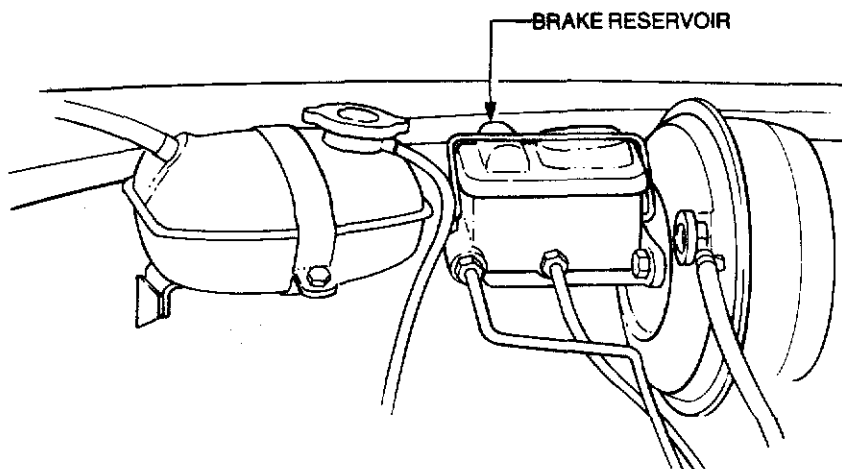

Figure 3-15 Brake reservoir

Clutch reservoir

342. Remove the reservoir cap and check that the fluid level in the clutch reservoir is up to the bottom of the filler neck. If necessary, top-up with clean brake fluid OX (Aust) 8. See Fig. 3-16) for reservoir location.

CLUTCH RESERVOIR

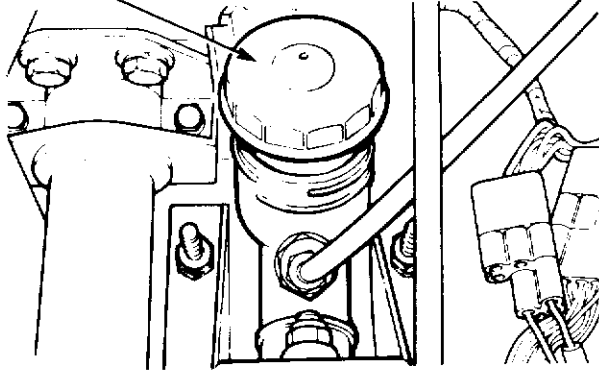

Figure 3-16 Clutch reservoir

**SIMPLEX COMPLETE EQUIPMENT SCHEDULE 12044
TRUCK, CARGO, LIGHT, MC2 — LANDROVER 110
LIABILITY CODE 74800/01**

ITEMS SUPPLIED/ISSUED WITH TRUCK

**PART 1— Principal Items
NIL**

PART 2A — Items Essential to Operation of Equipment

Item No.	NATO Stock No.	Designation	Unit of Issue	Quantity per sub-assembly	Quantity per equipment	Expendability classification	Foot-note
1	5120-66-48-8548	Baseplate, Jack, Wooden, 12 in x 12 in. x 2 in.		1	1	X	
2	6140-66-065-0681	Battery, Storage, 12V, 11 Plate, 80 Amp/hr, 305 mm 305 mm Lg x 175 mm x 225 mm H		1	1	N	
3	NIC	Battery, Storage, 15 Plate, 93 Amp/hr, 343 mm Lg x 173 mm W x 245 mm H (Exide Cycle X Plus, C X 4)		4	4	N	
4	8115-66-022-0114	Box, Small Parts, Plastics, 4-1/2 in. Lg x 2-1/2 in. W x 2-3/4 in. H, W/Lid		1	1	N	
5	7530-66-107-1001	Book, Record, TGM 120, Record Book for Service Equipment		1	1	X	A
6	NIC	Cover, Fitted, Vehicular Body		1	1	N	

Item No.	NATO Stock No.	Designation	Unit of issue	Quantity per sub-assembly	Quantity per equipment	Expendability classification	Foot-note
7	4210-66-089-8751	Extinguisher, Fire, Vaporizing Liquid, Bromochlorodifluoromethane, 1.50 kg Capacity, Stored Pressure, Regulated Discharge type			1	N	
8	4910-66-05 4679	Gauge, Tyre pressure, Self Contained, Portable Bar Type, 20 to 140 PSI Range, 2 PSI Calibrations, 165 mm O/A Lg W/Pocket Clip			1	X	
9	2610-66-010-7864	Inner Tube, Pneumatic Tyre, Light Truck, 7.50-16, TR15 Valve			1	N	B
10	5120-66-012-6101	Jack, Hydraulic, Hand, Double Lift, 7-1/2 in. Closed H, 17 in. Extended, 5 Ton W/Handle			1	N	
11	5120-66-014-0251	Pliers, Combination Side Cutting, W/Pipe Grip and Serrated Jaws, Insulated, 6 in. Nom. Lg			1	N	
12	4320-00-852-9036	Pump, Inflating, Manual, Hand Operated, Single Action, W/30 in. Lg Hose and Adaptor			1	X	
13	NIC	Bow, Vehicular, Canopy			2	N	
14	5140-66-067-5483	Roll, Tools and Accessories, Cloth Coated Nylon, 2 Pockets, 14 Loops, 690 MH mm x 350 mm W, W/2 Flaps			1	X	
15	5120-66-024-7832	Screwdriver, Crosstip, Cellulose Acetate Handle Phillips No. 3 x 150 mm Lg Blade 3-6			1	X	
16	5120-66--026-0206	Screwdriver, Flat Tip, Cellulose Acetate Handle, 8 mm W Tip x 150 mm Lg Blade			1	N	

Item No.	NATO Stock No.	Designation	Unit of Issue	Quantity per sub-assembly	Quantity per equipment	Expendability classification	Foot-note
17	NIC	Support, Canopy, Bow, Top Centre		1	1	N	
18	NIC	Support, Canopy, Bow, Side		2	2	N	
19	NIC	Tyre, Pneumatic, Light Truck, Tubed 7.50 R016 Lt, 10 ply Olympic Steel Trek		1	1	N	B
20	NIC	Wheel Chocks		2	2	N	
21	NIC	Wheel, Pneumatic Tyre 6.00 x 16		1	1	N	B
22	5120-66-016-1257	Wrench, Open End, Fixed, Double Ended, 15 Degree Offset, 1/2 in. and 9/16 in. A/F		1	1	N	
23	5120-66-013-6747	Wrench, Open End, Adjustable, 250 mm Nom. Size		1	1	X	
24	5120-66-016-1255	Wrench, Open End, Fixed, Double Ended, 15 Degree Offset, 5/8 in. and 11/16 in. A/F		1	1	N	
25	5120-66-016-0098	Wrench, Ring, Bi-Hexagon, Double Offset, Double Ended, 1/2 in. and 9/16 in. A/F		1	1	X	
26	5120-66-016-1851	Wrench, Ring, Bi-Hexagon, Double Offset, Double Ended, 5/8 in. and 11/16 in. A/F		1	1	X	
27	NIC	Wrench, Socket, Wheelnut, 4 Way Type 15/16 in. and 1-1/16 in. x 16. in. Nom. Lg O/A		1	1	N	



Part 2B — Optional Equipment — To Be Demanded Separately

NIC	Equipment Kit, Vehicular Light, MC2, 6x6, 4 Cylinder Diesel Engine, Manual Transmission, Shelter Installation, Small 12V Electrical System, Land Rover Model 110 Series (PSCES) 004/86)	1	N
-----	--	---	---

Footnotes

- A. Individual pages to be demanded as per User Catalogue for Stationary Supplies (Forms).
- B. Spare.

SIMPLEX COMPLETE EQUIPMENT SCHEDULE 12045 EQUIPMENT KIT

ITEMS REQUIRED TO MAKE UP THE EQUIPMENT KIT

PART 1— Principal Items NIL

PART 2A — Items Essential to Operation of Equipment

Item No.	NATO Stock No.	Designation	Unit of Issue	Quantity per sub-assembly	Quantity per equipment	Expendability classification	Foot-note
1	5110-66-011-0377	Axe, Single Bit, 2 kg, 820 mm Lg			1	X	
2	7240-66-021-5710	Can, Dispensing, Funnel Top, Tin Plate, 1 pint Capacity, W/O Handle			1	X	
3	7240-99-802-2405	Can, Gasoline, Military, Steel, 22 Litre			1	X	
4	8110-66-016-0717	Can, Screw Cap, Oil Rect Shape, 5 Litre			1	N	
5	7240-66-054-8602	Can, Water, Military, Plastics, 22 Litre			1	X	
6	2640-00-060-3550	Cap, Pneumatic Valve, Brass			7	X	
7	4010-66-086-8464	Chain Assembly, Single Leg, Alloy Steel, 4 m Lg, 0.500 in. Dia, SWL 10 080 lb Hook Other End 4 m Lg, 10 080 lb SWL			1	N	
8	5120-66-012-6821	Handle, Mattock-Pick, 5 lb. Pick			1	X	
9	5340-66-025-0498	Holder Key, Steel, 3/4 in. ID			1	X	
10	5970-66-018-8475	Insulation Tape, Electrical, Black, 18 mm W x 33 m Lg			1	X	

Item No.	NATO Stock No.	Designation	Unit of issue	Quantity per sub-assembly	Quantity per equipment	Expendability classification	Foot-note
11	6240-00-155-7900	Lamp, Incandescent, 12V, 6 to 21 CP, Double Contact Bayonet Base, 'B' Shape, Clear			2	X	
12	6240-66-026-0478	Lamp, Incandescent, 12V, 40/50 W, Double Contact Prefocus Base, 'T' Shape, Clear			2	X	
13	6240-66-010-7460	Lamp, Incandescent, 12V, 5 W, Single Contact Bayonet, Candelabra Base, 'G' Shape, Clear			3	X	A
14	6240-66-010-8161	Lamp, Incandescent, 12V, 21 W, Single Contact Bayonet, Candelabra Base, 'S' Shape, Clear			2	X	
15	6240-66-022-6561	Lamp, Incandescent, 12V, 3 W, Single Contact Bayonet (BA 15S) Base, G-6 Shape, Clear			2	X	
16	6230-99-942-7876	Light, Extension, C/W Cable and Plug, W/O Globe			1	N	
17	5340-66-020-2790	Padlock, Brass, Solid Case, Steel Shackle, 45 mm in. W, 19 mm Shackle Clearance			3	X	
18	5120-66-012-6893	Pick, Digging, W/O Handle, 5 lb.			1	X	
19	4030-66-123-1450	Shackle, Dee, Alloy Steel, Quality Grade S, 19 mm Nom Size, C/W Metric Thd Collared Eye			2	X	
20	5120-66-093-8563	Pin, 4.7 Tonne WLL, Zinc Coated			1	X	
21	9905-66-018-3897	Shovel, Hand, GS, Rd Point Blade, Plastic D-Handle, Black or Dark Green, 35-1/2 in. LG O/A			3	X	
22	9905-66-048-0206	Sign, Warning, Portable, Motor Vehicle			2	X	
23	2640-00-050-1229	Tag, Marker, Brass, Rd, 1-1/4 Dia. Valve Core, Pneumatic Tyre			7	X	

Item No.	NATO Stock No.	Designation	Unit of issue	Quantity per sub-assembly	Quantity per equipment	Expendability classification	Foot-note
----------	----------------	-------------	---------------	---------------------------	------------------------	------------------------------	-----------

24	6145-66-014-2971	Wire, Electrical, No. 20 SWG	RL	1		X	
----	------------------	------------------------------	----	---	--	---	--

Part 2B — Optional Equipment — To Be Demanded Separately

Footnotes

A. One is for the light, the remainder are spares.



INDEX

A

	Para.
Accelerator pedal.....	66
Accessories, electrical	46-78
Air cleaner	340
Air distribution control.....	52
Air temperature control	51
Angles, approach and departure	33
Auxiliary power socket.....	48
Axle, front	9, 39, 332
Axle, rear	10, 41, 330

B

Blackout lighting.....	47
Bleeding the fuel system.....	315
Body and chassis fittings.....	80-103
Bonnet, opening.....	65, 312
Brake, parking	45, 73, 227
Brake pedal	67
Brake reservoir.....	341
Brakes, service.....	43
Brakes, vehicle.....	15
Braking.....	225
Bridge classification.....	29, 102

C

Cabin dome light switch	62
Cabin heating	50
Cabin ventilation	46
Cabin seating	79
Camouflage net lashing points	103
Canopy.....	235
Canopy bow stowage	234
Capacities.....	27
Carrying capacity, troop	24
Changing a wheel	232
Chassis	16

	Para.
Chassis and body fittings.....	80-103
Cigar lighter.....	72
Classification bridge.....	29, 102
Cleaner, air.....	340
Clutch.....	6, 223
Clutch pedal.....	71
Clutch reservoir.....	342
C of G designation plate.....	100
Combination switch.....	55
Controls, air distribution.....	52
Cooling system.....	2
Coolant temperature gauge.....	59
Cross-country driving.....	230

D

Data servicing.....	96
Data summary.....	1-33
De-ditching tools.....	89
Dimensions.....	26
Driving habits.....	221-231

E

Electric windscreen washers.....	61
Electrical.....	307
Electrical, accessories.....	46-78
Electrical system.....	18
Electrical system ignition/start switch.....	68
Electrical trailer connection socket.....	91
Engine.....	1, 36
Engine accessory drive.....	3
Engine oil and oil filter change procedure.....	321-323
Engine starter.....	5
Engine, starting.....	219
Engine, stopping.....	226
Engine temperature.....	221
Engine warning lights.....	58
External lighting.....	19
Extinguisher, fire.....	88

F

Fan control	50
Filter, fuel	338
Filter, oil	321-323
Fire extinguisher	88
First parade servicing	301-305
Flywheel housing drain	228-229
Fording depth	28, 228
Front axle	9, 39, 332
Front suspension	12, 40
Fuel filter	339
Fuel gauge	57
Fuel sedimenters	339
Fuel switch	53
Fuel system	4
Fuel system, bleeding	315
Fuse box	76
Fuses	22

G

Gauge, coolant temperature	59
Gauge, fuel	57
Gear changing	224
Gear lever	74
Good driving habits	221-231
Ground clearance	30

H

Habits, driving	221-231
Halts on the march	309-310
Hand throttle	64
Hazard switch	63
Headlights/park lights	69
Heater controls	50-52
High/low beam dipper switch	55
Horn, electric	55

I

Ignition switch	68
Instruments	46-78
Instrument lights	49
Intermediate axle	329
Introduction	34

J

Jacking plate	99
Jerrican stowage	86

K**L**

Last parade servicing	311
Lights, warning	58
Lights, instrument	49
Light, map reading	78
Lighting, blackout	47
Lighting, external	19
Lighting, internal	20
Lighting, military	21
Lighting, reduced	47
List of agents	215

M

Maintenance, periodical	316
Map reading light	78
Military lighting	21
Mirrors, rear vision	94
Moving off and running	308
Moving the vehicle	220

N

Nomenclature plate	95
Normal, blackout and reduced lighting	47

O

Odometer	56
Opening bonnet for servicing access.....	312
Operational and logistic concepts.....	35
Operation, vehicle.....	216-236
Oil filter and engine oil change procedure.....	321-323

P

Panel lights.....	49
Parking.....	227
Parking brake.....	45, 73
Pedal, accelerator.....	66
Pedal, brake.....	67
Pedal, clutch.....	71
Performance.....	23
Periodical maintenance.....	316
Pintle, towing.....	92, 337
POL stowage.....	86
Plate, C of G designation.....	100
Plate, jacking procedure.....	99
Plate, main transmission shift diagram.....	74
Plate, nomenclature.....	95
Plate, servicing data.....	96
Plate, shipping data.....	97
Plate, towing and dyno test data.....	98
Propeller shafts.....	11, 336

Q

R

Radiator coolant, top-up.....	314
Rear axle.....	10, 41, 330
Rear seat stowage.....	236
Rear side windows.....	85
Rear suspension.....	13, 42
Rear vision mirrors.....	94
Rear window.....	83
Reduced lighting.....	47
Reservoir, brake.....	341
Reservoir, clutch.....	342





NOTES

NOTES





NOTES

NOTES





NOTES

NOTES

