

Registry of Ex Military Land Rovers

Copyright of this document is retained by the original authors. Some parts may have been superseded or changed since that time.

This document has been download from the Registry of Ex Military Land Rovers at <http://www.remlr.com> . All files available from this site are free of charge.

If you have paid for this document please report where you purchased it from to the Registry of Ex Military Land Rovers Inc at webmaster@remlr.com



7610-66-128-4346



AUSTRALIAN ARMY

TECHNICAL MANUAL

USER HANDBOOK

TRUCK, UTILITY, LIGHTWEIGHT, WINCH, MC2

2320-66-128-4219
(LIABILITY CODE No. 72510/10)
Specification Army (Aust) 6426
Headquarters Logistic Command
1988

Issued by Command
of the Chief of the
General Staff

A handwritten signature in black ink, appearing to read 'D. M. M. Francis'.

(D. M. M. Francis)
Major General
Chief of Materiel

AMENDMENT RECORD

Amendment No.	Actioned by: Signature and Date

SYNOPSIS

The Truck, Utility, Lightweight, Winch, MC2 is a 4 x 4 wheeled Army version of the Land Rover 110 Series commercial vehicle with constant four-wheel drive. Chassis modifications are incorporated for helicopter slinging, shipping tie-down and vehicle recovery points. The primary role of the vehicle is the movement of cargo and/or personnel on sealed or second class roads and under cross-country conditions. The vehicle's load carrying capacity is 900 kg.

The vehicle has a range of approximately 550 km on first class roads. When loaded, it is rated to tow a gross trailer mass of 900 kg. However, for emergency operations a similarly equipped vehicle (less trailer) could be towed.

WARNING

Page No.

WARNING

52

Should the engine become overheated, park the vehicle in a safe working area and allow the engine to cool before attempting repairs to, or refilling of, the cooling system.

WARNING

53

Because of the excellent rough terrain characteristics of this vehicle, drivers are cautioned to maintain a safe speed for the conditions encountered especially when towing a trailer or utilizing tyre chains.

WARNING

54

The parking brake acts on the transmission, not the rear wheels. The differential lock must be engaged and the wheels chocked to enable the vehicle to be raised safely.

WARNING

57

Always wear industrial gloves when handling steel wire rope. Do not use the hands to guide the rope on or off the drum when winching.

WARNING

64

Ensure that the bonnet support stay is properly locked before releasing the bonnet.

WARNING

This vehicle is painted in polyurethane paint. Precautions should be taken prior to carrying out repairs which include painting, sanding, scraping or welding. For safety precautions refer to Introduction Into Service Instruction, Materiel Management Policy Statement, Painting Policy for Vehicles and Equipment or relevant EMEI.

LIST OF CONTENTS

Preliminary Pages		Page No.
Synopsis		iii
Warnings		iv
List of contents		v
List of illustrations		vi
List of tables		viii
Associated publications		ix
Frontispiece		x
Maintenance Supply Item identification		xi

Chapter	Section	Heading	Page No.
1		General description	1
	1	Data summary	2
	2	Shipping and transportation data	11
	3	Equipment description	14
2		Operating instructions	35
	1	Warranty and repair	36
	2	Vehicle operation	50
3		Operator servicing	61
	1	Servicing	62
	2	Lubrication	76
		Complete Equipment Schedule (CES)	86
		Index	92

LIST OF ILLUSTRATIONS

Fig. No.		Page No.
1-1	Truck, Utility, Lightweight, Winch, MC2 — front view	x
1-2	Truck, Utility, Lightweight, Winch, MC2 — rear view	x
1-3	Slinging and tie-down points	13
1-4	Heater fan control	17
1-5	Combination switch operation	17
1-6	Warning lights	19
1-7	Air temperature and distribution controls	21
1-8	Windscreen washer and wiper control	21
1-9	Hazard warning and cab dome light switches	22
1-10	Main lighting switch	23
1-11	Bonnet safety catch	24
1-12	Gear change pattern	24
1-13	Transfer case shift pattern	25
1-14	Fuses	25
1-15	Seat adjustment	26
1-16	Spare wheel lowering	27
1-17	Seat belt anchorage	27
1-18	Vehicle nomenclature plate	28
1-19	Servicing data and tyre pressure plate	28
1-20	Shipping data plate	29
1-21	Towing and dyno test data plate	29
1-22	Jacking procedure plate	30
1-23	Winch operation decal	30
1-24	Instruments, electrical accessories and controls	33
2-1	Starter switch positions	50
2-2	Flywheel housing drain	53
2-3	Jack position — front wheels	55
2-4	Jack position — rear wheels	55
2-5	Canopy retaining latches	56
2-6	Winch dog-clutch operation	58
2-7	Winch/PTO control operation	59
3-1	Thermostat housing	65
3-2	Bleeding the fuel system	66
3-3	Lubrication and oil drain/refill points	76
3-4	Winch and winch drive line	77
3-5	Engine right hand side	78
3-6	Oil filter removal	78
3-7	Transmission drain and fill plugs	79
3-8	Transfer case drain and fill plugs	80
3-9	Rear axle drain and fill plugs	80
3-10	Swivel pin housing drain and fill plugs	81

LIST OF ILLUSTRATIONS

Fig. No.		Page No.
3-11	Fuel filter	82
3-12	Fuel sedimenter	82
3-13	Air cleaner removal	83
3-14	Air cleaner elements	83
3-15	Brake reservoir	84
3-16	Clutch reservoir	84
3-17	Winch fill plug	85

LIST OF TABLES

Table No.	Title	Page No.
1-1	Location of identification numbers on MSI's	xi
2-1	Pro-rata warranty	36
2-2	JRA State offices	39
2-3	Land Rover dealers	39
3-1	Daily tasks	67
3-2	Fortnightly tasks	68
3-3	Initial servicing	68
3-4	Minor servicing	70
3-5	Major servicing	72
3-6	List of lubricants	76

ASSOCIATED PUBLICATIONS

1. Standing Orders for Vehicle Operation and Servicing
2. Australian Army Books:
TGM 120 Record Book for Service Equipment — Army
3. Complete Equipment Schedules (CES):
(a) SCES 12037 } Truck, Utility, Lightweight,
(b) Equipment Kit SCES 12036 } Winch, MC2
4. Block Scale 2406/31 Issue 1 — Special Tools for RAEME –
B Vehicles – Truck Utility and Truck Light MC2 (Land Rover
Model 410)
5. EMEI VEH A029 — Servicing of B Vehicles
6. EMEI VEH A119-22 — Repair of Vehicles Under Warranty
Agreement — Policy Statement
7. EMEI VEH G100-1 — Data Summary
8. EMEI VEH G102 — Technical Description
9. EMEI VEH G103 — Unit Repair
10. EMEI VEH G104 — Field Repair
11. EMEI VEH G104-1 — Base Repair
12. EMEI VEH G109 — Servicing Instruction
13. Australian Change In War Materiel 31171
14. Repair Parts Scale 02189

FRONTISPIECE

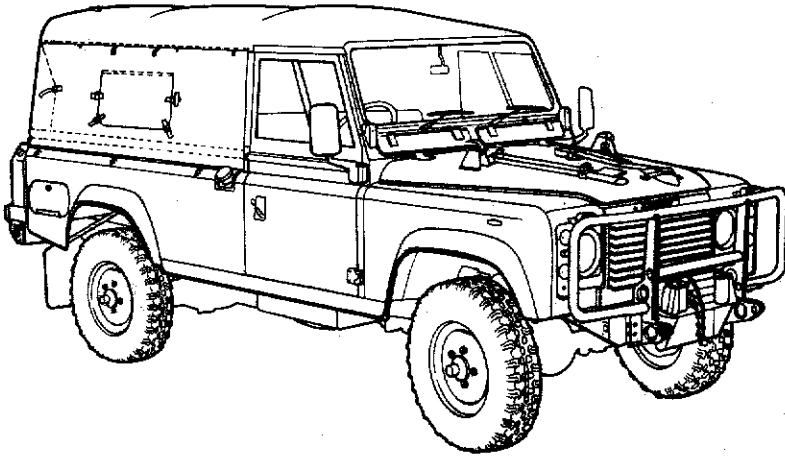

Figure 1-1 Truck, Utility, Lightweight, Winch, MC2 — front view

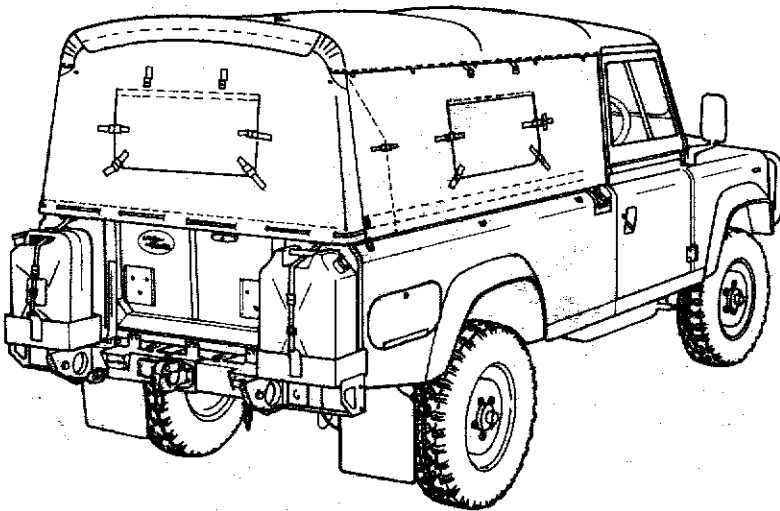

Figure 1-2 Truck, Utility, Lightweight, Winch, MC2 — rear view

MAINTENANCE SUPPLY ITEM IDENTIFICATION

Table 1-1 Location of identification numbers on MSI's

Chassis No. — Right hand side of the chassis, forward of
the spring mounting turret

Chassis nameplate — Left hand seat box in the cab

Engine No. — Left hand side of the engine block

Injection pump identification — Side of the pump

Transmission and transfer case — Rear of the transfer case

Front axle No. — Adjacent to the axle breather

Rear axle No. — Adjacent to the axle breather





CHAPTER 1

GENERAL DESCRIPTION

SECTION 1 — DATA SUMMARY

**SECTION 2 — SHIPPING AND
TRANSPORTATION
DATA**

**SECTION 3 — EQUIPMENT
DESCRIPTION**

SECTION 1 DATA SUMMARY

NOTE

Throughout this manual all references to left hand (LH) and right hand (RH) are as viewed from the rear of the vehicle looking forward.

Truck Model No.	Land Rover 110
1. Engine	
Manufacturer	Isuzu
Type	4BD1 series naturally aspirated water cooled, four-cylinder in-line, overhead valve four-cycle diesel with direct injection.
Displacement	3.856 litres
Bore	102 mm
Stroke	118 mm
Compression ratio	17:1
Firing Order	1-3-4-2
Power	66 kW at 3200 rpm
Maximum torque	245 Nm at 1900 rpm
Engine operating range (Ideal)	1000 to 3200 rpm
No load maximum	3200 rpm
Engine idle speed	580 ± 25 rpm
Oil capacity (Including filter)	8.5 litres
Oil filter	External full-flow spin-on
Oil Pressure	390-580 kPa at 2400 rpm

Oil cooler Water cooled, plate and tube type

Engine weight, dry 322.5 kg

2. Cooling system

Type Pressurised spill return system with thermostat control, pump and fan assisted.

Capacity 12.5 litres

Thermostat Downward opening wax element type incorporating by-pass shut-off valve. Opening temperature 82 °C.

Coolant Water with 5% ALFLOC 2001 inhibitor

3. Engine accessory drive

Type Single V-belt

Tension Approx. 10–15 mm deflection midway along the longest span using moderate thumb pressure.

4. Fuel system

Fuel Pump Diesel Kiki (Bosch) in-line A-type DH100 with automatic timer

Governor RLD-K Mechanical

Transfer pump KS Mechanical with gauze intake filter

Injectors Four-hole spray type nozzle

Main filter Inlet manifold mounted spin-on type

Sedimenter Chassis mounted CAV SS type sedimenter

Fuel tank Single tank of 65 litres

5. Engine starter

Manufacturer Mitsubishi

Type Waterproof, gear reduction

6. Clutch

Manufacturer Repco/Isuzu

Type Hydraulically operated single dry plate and diaphragm spring

Free travel (pedal) 6 mm minimum

7. Transmission

Manufacturer Land Rover

Type Model LT95A, four forward, one reverse, synchromesh on all forward gears. Incorporates integral transfer case

Ratios	First gear	4.069:1
	Second gear	2.448:1
	Third gear	1.505:1
	Fourth gear	1.000:1
	Reverse gear	3.664:1

8. Transfer case

Manufacturer Land Rover

Type High and low gear ratios operating on the main transmission output. Front and rear drive are permanently engaged via a differential. The differential is lockable for traversing difficult terrain.

Ratios	High range	0.996:1
	Low range	3.321:1

9. Power take-off (PTO)

Manufacturer Land Rover

Type Variable speed, chain-driven. Integral with transfer case and incorporates torque limiter.

10. Winch

Manufacturer	Winch Industries
Type	Thomas T8000M
Ratio of reduction gear	50:1
Maximum cable pull	
First layer on drum	3636 kg
Second layer on drum	3024 kg
Third layer on drum	2589 kg
Fourth layer on drum	2263 kg
Winch rope	
Type	Right hand ordinary lay with an independent wire rope core.
Diameter	10 mm
Length	45 metres
Minimum breaking force	63.1 kN
Oil capacity	1.3 litres

11. Front axle

Manufacturer	Land Rover
Type	Fully floating spiral bevel steerable drive axle with enclosed outboard constant velocity joints and two pinion differential
Ratio	3.54:1
Track	1498 mm
Load rating	1350 kg

12. Rear axle

Manufacturer	GKN/Salisbury
Type	Salisbury 8HA, fully floating hypoid bevel drive axle with offset four pinion differential
Ratio	3.54:1

Track 1498 mm

Load rating 1950 kg

13. Propeller shafts

Type Single Hookes universal needle roller joints. Repco 1310 sliding section on front gaitered, rear shaft open.

14. Front suspension

Type Radius arms and Panhard rod located live axle with vertically mounted double acting telescopic shock absorbers inside single rate coil springs

Load rating 1350 kg

15. Rear suspension

Type Trailing arms and an upper centrally mounted A-frame located axle, with vertically mounted single rate coil springs damped by double acting telescopic shock absorbers

Load rating 1950 kg

16. Steering

Manufacturer Gemmer

Type Worm and roller

Steering gear ratio 20.55:1

Lock to lock 4.4 turns

Turning circle

Between kerbs 13.0 metres (nominal)
Between walls 13.7 metres (nominal)

17. Brakes

Type	Hydraulic split system with front disc and rear drum brakes, foot pedal actuated
Parking brake	Cable operated, transmission drum brake
Warning devices	Dash mounted globes indicating front brake pad depth (actuated at 3 mm thickness), a failed hydraulic circuit, and parking brake applied

18. Chassis

Type	Hot dip galvanized welded box section steel with welded box section crossmembers
Wheelbase	2794 mm

19. Wheels and tyres

Rim, type and size	Ventilated disc, 6F x 16
Tyre size	750-R-16LT 10 ply Olympic Steeltrek with 105 pattern
Tyre pressure (cold)	Highway: front 250 kPa (36 psi) rear 350 kPa (50 psi)
	Cross-country: front 200 kPa (29 psi) rear 275 kPa (40 psi)
	Sand: front 150 kPa (22 psi) rear 225 kPa (33 psi)

20. Electrical system

System voltage	12 volt negative earth
Battery	12 volt, cold cranking performance of approximately 410 amps. Located under left hand front seat
Alternator	Hitachi 12 volt 70 amp

21. Lighting, external

Head lights, high/low

Park lights

Stop and tail lights

Turn indicator lights

Side indicator lights

Reverse lights

Number plate lights

Location, quantity and wattageFront of vehicle, 2 off, 60/55 watt
Halogen

Front of vehicle, 2 off, 5 watt

Rear of vehicle, 2 off, 21/6 watt

Each corner of vehicle, 4 off, 21 watt

Front mudguards, 2 off, 4 watt

Rear of vehicle, 2 off 10 watt

Rear of vehicle, 2 off, 4 watt

22. Lighting, internal

Dome light

Map light

Instrument lights — except
speedometer

Speedometer light

Warning lights — except low
fuel

Low fuel light

Hazard switch warning light

Location, quantity and wattage

Roof of cab, 1 off, 21 watt

Left hand side of instrument panel, 1 off,
5 watt Halogen

Instrument panel, 3 off, 2 watt

Instrument panel, 2 off, 3 watt

Instrument panel, 10 off, 1.2 watt

Instrument panel, 1 off, 3 watt

Dashboard, 1 off, 0.6 watt

23. Lighting, military

Blackout lights

Convoy light

Reduced head lights

Location, quantity and wattageFront and rear of vehicle, 4 off,
replaceable module

Rear of vehicle, 1 off, 2 watt

Front of vehicle, 2 off, 18 watt

24. Fuses

Rating (continuous)

Located inside the cab, centre console, behind protective panel

Head lights 4 off, 8 amp

Park lights 2.5 amp

Horn, dome light 10 amp

Hazard lights 10 amp

Reverse lights 10 amp

Windscreen wiper, washer 12 amp

Fan 10 amp

Spare 8 amp

Stop lights, instruments, turn indicators 10 amp

Blackout lights 8 amp

Reduced head lights 8 amp

Located under bonnet, near brake master cylinder/
booster

Stop/start control motor 10 amp

25. Performance

Gradeability (both directions) cross-country laden 60 per cent gradient (31 degree slope)

Range of operation 550 km (first class roads) approx.
430 km (second class roads) approx.

Fuel consumption 12 litres per 100 km (Highway laden).
15 litres per 100 km (second class laden.) Fuel tank capacity 65 litres

26. Troop carrying capacity

Fully kitted 8 (including driver)

27. Tray body load area

Width — Floor level	915 mm
— Between seats	660 mm
— Above seats	1440 mm
Length	1970 mm

SECTION 2 SHIPPING AND TRANSPORTATION DATA

28. Dimensions

Overall length	4830 mm
Wheelbase	2794 mm
Overall width — Over mirrors — Reduced	2058 mm 1800 mm
Overall height — Laden — Unladen	1953 mm 2040 mm
Cut down height — Laden — Unladen	1490 mm 1530 mm
Track — Front — Rear	1498 mm 1498 mm
Cargo tray	
Length — Internal	1835 mm
Width — Internal	1440 mm
Height of body sides (from tray)	265 mm
Height of cargo tray from ground	
— Laden	710 mm
— Unladen	825 mm
Rear axle to rear of vehicle/overhang	1200 mm
Towing pintle height — Laden — Unladen	520 mm 640 mm
Mass (Unladen)	
— Front	1300 kg
— Rear	1000 kg
— Total	2300 kg

29. Capacities

Equipment	DEF (AUST.) 206	METRIC (litres)
Engine system (including filters)	OMD-115	8.5
Cooling system (including inhibitor)		12.5
Transmission	OMD-115	2.7
Transfer case	Castrol FMX	5.8
Front axle	OEP-220	1.7
Rear axle	OEP-220	2.3
Swivel pin housings (each)	OEP-220	0.35
Winch	OEP-220	1.3
Fuel tank	Diesel fuel-distillate	65

NOTE

See EMEI VEH G 109 for list of approved lubricants.

30. Forging depth

Unprepared vehicle	500 mm
Limiting features (over 500 mm)	Cooling fan
Prepared vehicle	No facility available, as for unprepared vehicle

31. Bridge classification

Solo unladen 4

32. Ground clearance

Unladen 215 mm

Limiting feature Rear differential housing

33. Transportability

Railway loading gauges (Local authorities must be consulted)

Rail authority	Gauge	Maximum rolling stock height
Commonwealth	1435 mm	2532 mm
Commonwealth	1067 mm	2532 mm
New South Wales	1435 mm	2182 mm
Queensland	1067 mm	1806 mm
South Australia	1600 mm	2075 mm
South Australia	1435 mm	2075 mm
South Australia	1067 mm	1761 mm
Tasmania	1067 mm	1992 mm
Victoria	1600 mm	2182 mm
Victoria	1435 mm	2182 mm
Western Australia	1435 mm	2532 mm
Western Australia	1067 mm	1973 mm

34. Slinging and tie-down points are illustrated in Fig. 1-3.

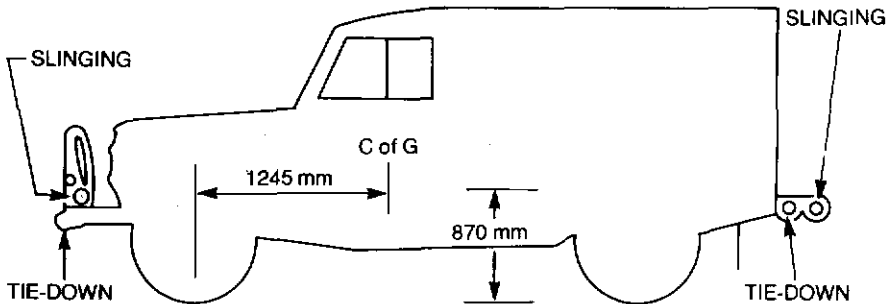

Figure 1-3 Slinging and tie-down points

35. Approach and departure angles

Approach angle — Unladen	45 degrees
— Laden	41 degrees
— Limiting feature	Emergency towing lugs

Departure angle — Unladen	33 degrees
— Laden	27 degrees
— Limiting feature	Helicopter lifting bracket

Ramp angle — Unladen	148 degrees
— Laden	154 degrees
— Limiting feature	Chassis

SECTION 3

EQUIPMENT DESCRIPTION

Introduction

36. The truck, utility, lightweight, winch, MC2 is based on the Land Rover 110 commercial vehicle with modifications to meet operational requirements. The vehicle incorporates a main transmission and integral transfer case, with gearing designed to enable the vehicle to negotiate any terrain or gradient that will allow wheel traction. In practice, this is limited to a 60 per cent gradient. The vehicle is fitted with a 3.9 litre Isuzu diesel engine and utilizes permanent four-wheel drive.

Operational and logistic concepts

37. This vehicle provides the general wheeled support for first line tasks. The vehicle is fitted with a removable canopy and can be utilized to transport up to one tonne of stores or eight fully-kitted troops, including the driver.

Engine

38. The vehicle is fitted with an Isuzu 4BD1 naturally aspirated four cylinder diesel engine, which produces 66 kW at 3200 rpm and 245 Nm torque at 1900 rpm.

Transmission

39. The main transmission is a heavy duty four-speed all-synchromesh transmission with an integral two-speed transfer case. Clutch and gear operations are manual, without power assistance.

Transfer case and power take-off (PTO)

40. The transfer case, which is cast as part of the main transmission, provides high and low gear ratios for on and off road driving. The low ratio is used for low speed operations, while the high ratio is used for driving at higher speeds. A differential within the transfer case prevents wind-up between the front and rear axles. However, for extreme driving conditions or where traction is difficult, the differential must be locked by means of the driver-operated switch, located on the dashboard, to give the vehicle positive all-wheel drive.

41. The parking brake operates a single drum brake which is mounted on the rear output shaft of the transfer case.

42. The transfer case also incorporates a chain-driven PTO with torque limiter, which provides the drive for the front mounted winch.

Winch

43. A Thomas T8000M winch is fitted to the front of the vehicle, between the chassis rails and below the grille. Drive for the winch comes from the PTO via the torque limiter and a three-piece propeller shaft. The winch has a reduction ratio of 50:1 and is fitted with 45 metres of 10 mm diameter wire rope.

44. There are two dog-clutches in the winch drive line, one in the PTO and the other at the winch. The PTO dog-clutch is cable actuated from within the cab while the winch dog-clutch, which allows free-spooling of the cable, is lever-operated at the winch.

Steerable front drive axle

45. The vehicle is fitted with a steerable front drive axle, comprising a differential carrier assembly and axles, driving through constant velocity joints to steerable drive ends fitted with hydraulically operated disc brakes.

Front suspension

46. The front suspension utilizes radius arms, a Panhard rod, vertically mounted double acting telescopic shock absorbers and single rate coil springs. Bump stops are provided to limit the upward travel of the suspension, while the shock absorbers limit the downward travel of the axle.

Rear axle

47. The rear axle is a Salisbury type fully floating hypoid bevel drive axle with an offset four pinion differential.

Rear suspension

48. The rear suspension utilizes long travel coil springs, radius arms and A-frame location arm with double acting telescopic shock absorbers. Bump stops are provided to limit the upward travel of the suspension, while the shock absorbers limit the downward travel of the axle.

Service brakes

49. The vehicle is fitted with a dual circuit hydraulic brake system consisting of two completely separate circuits. The primary circuit supplies the rear drum brakes and the secondary circuit supplies the front disc brakes.

50. Brake pad wear indicators are fitted to the front left hand caliper and will actuate a brake circuit warning light on the dashboard when brake pad thickness is reduced to approximately 3 mm. In addition, the warning light will illuminate if fluid loss occurs from either the primary or secondary brake circuit.

Parking brake

51. A single drum brake is mounted on the rear output shaft of the transfer case. This brake, which is mechanically operated by the parking brake lever in the cab, is completely independent of the foot operated hydraulic brake system.

Instruments, electrical accessories and controls (see Fig. 1-24)

52. Ventilator control (Fig. 1-24 items 1 and 5).

Two ventilators are provided in the windscreen frame, which may be opened independently by pushing the appropriate control lever downwards.

53. Normal, blackout and reduced lighting switch (Fig. 1-24 item 2)

This three-position switch, located on the fascia panel, controls the vehicle lighting as follows:

- a. In the NORMAL or left position, all vehicle lighting operates via the usual controls.
- b. In the BLACKOUT or mid position, all of the NORMAL lighting, with the exception of dash instrument, warning and map reading lights, is switched off. In this mode, the blackout stop lights will function when the brakes are applied, and the blackout marker lights at the front and rear of the vehicle are illuminated. The convoy light also operates in this mode.
- c. In the REDUCED or right position, the reduced head lights are utilized in addition to the blackout lighting. The dash instrument lights and map reading light can also be used.

54. Transfer case control switch (Fig. 1-24 item 3)

The transfer case is fitted with a differential which allows the vehicle to be operated on road without transmission wind-up. This differential is controlled by a dash mounted two-position switch. The switch should be pushed in for on road use and pulled out when traction is difficult, thereby providing positive all-wheel drive.

55. Panel light dimmer control (Fig. 1-24 item 4)

The instrument panel light intensity can be adjusted by the dimmer control, which functions irrespective of which of the three modes of lighting is selected. The switch also has an ON-OFF control.

56. Heater fan control (Fig. 1-24 item 6)

A three-position switch controls the heater fan as follows:

- a. When the lever is in the upper position (see Fig. 1-4) the heating and ventilation system is inoperative.
- b. When the lever is mid-way, air is forced into the vehicle by its

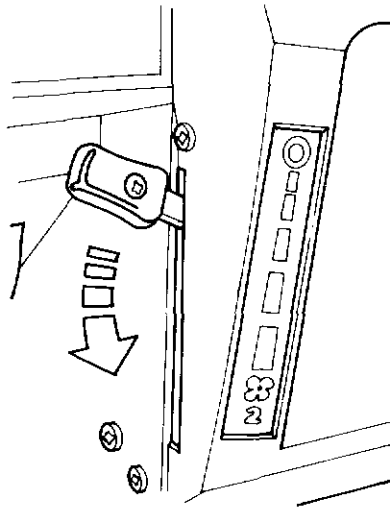

Figure 1-4 Heater fan control

forward movement and then ducted and heated as determined by the air distribution and heat control levers. As this is a forced air system, it is inoperative when the vehicle is stationary.

- c. Low speed or high speed fan operation is provided when the lever is moved down to the first or second stop respectively. Air will be forced into the vehicle then ducted and heated as determined by the air distribution and heat control levers. The fan motor will only operate with the engine running or the ignition on.

57. Combination switch (Fig. 1-24 item 7)

The combination switch has six positions and provides control over the head lights, turn indicators and the horn. The switch operates as follows (see Fig. 1-5):

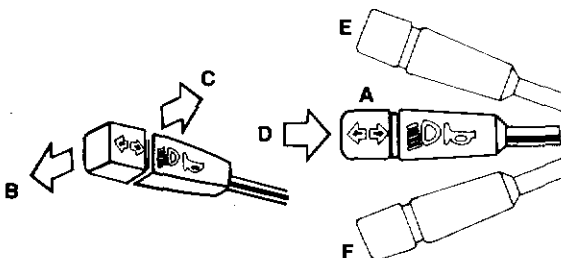

Figure 1-5 Combination switch operation

- a. With the switch in the central position (A), the head lights will be dipped.
- b. With the switch pushed away from the driver (B), the head lights will be on high beam.
- c. Pulling the switch toward the driver (C), will flash the head lights. This operation can be achieved at any time, irrespective of other switch positions.
- d. Pushing the switch knob inward (D), will operate the horn.
- e. With the switch in the upper position (E), the right hand turn indicators will flash.
- f. With the switch in the lower position (F), the left hand turn indicators will flash.

58. The combination switch functions are not available during blackout conditions.

59. Speedometer and odometer (Fig. 1-24 Item 8)

The speedometer indicates the road speed in kilometres per hour and the total distance travelled. A trip meter is incorporated in the speedometer together with its associated reset button.

60. Fuel gauge (Fig. 1-24 Item 9)

The fuel gauge indicates the approximate contents of the fuel tank.

61. Warning light cluster (Fig. 1-24 Item 10)

The warning lights provide a visual indication that a fault has occurred in one or more of the systems represented by the warning lights.

- a. The oil pressure warning light (Fig. 1-6 item 2) indicates when the oil pressure is insufficient for safe engine operation. The light should illuminate when the ignition is turned on and extinguish once normal engine oil pressure is established. If this light illuminates during normal running, the vehicle should be stopped immediately and the cause determined.
- b. The ignition warning light (Fig. 1-6 item 3) indicates a malfunction in the battery charging circuit. The light should illuminate when the ignition is turned on and extinguish once the engine is running.
- c. The brake circuit warning light (Fig. 1-6 item 4) indicates that leakage has occurred from either the front or rear brake circuit. In this case, the light will illuminate when the foot brake is applied. In addition, a brake pad wear indicator is fitted to the front left hand caliper and will actuate the light when the pad thickness is reduced to approximately 3 mm. Normally, the light will illuminate momentarily when the ignition is turned on, then extinguish. If the light illuminates during normal

running, the vehicle should be stopped immediately and the cause determined.

- d. The turn indicator warning light (Fig. 1-6 item 5) flashes when the turn indicator lights are functioning. Both arrows will flash as the turn indicator is operated by the switch on the steering column. If the light does not flash, there may be a blown globe in the warning light or one of the turn indicators.
- e. The high beam warning light (Fig. 1-6 item 6) illuminates when the head light high beam has been selected. The light also illuminates when the head light flasher is used.
- f. The low fuel warning light (Fig. 1-6 item 7) illuminates when there is approximately nine litres of fuel left in the fuel tank and will remain illuminated until the fuel supply is replenished. When cornering, the light may flash intermittently before the fuel reaches the nine litre level.

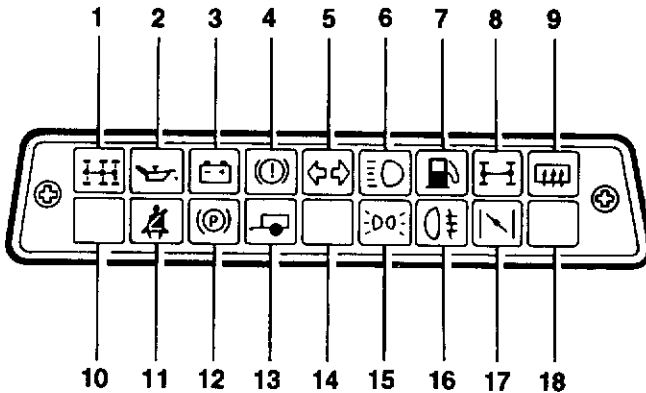

1.	Not used	Red
2.	Oil pressure	Red
3.	Ignition	Red
4.	Brake circuit	Red
5.	Turn indicators	Green
6.	High beam	Blue
7.	Low fuel	Amber
8.	Differential lock	Amber
9.	Not used	Amber
10.	Not used	Red
11.	Not used	Red
12.	Parking brake	Red
13.	Trailer	Green
14.	Not used	Green
15.	Park lights on	Green
16.	Not used	Amber
17.	Cold start (glow plugs)	Amber
18.	Not used	Amber

Figure 1-6 Warning lights

- g. The differential lock warning light (Fig. 1-6 item 8) illuminates when the transfer case control switch is operated and the transfer case differential is engaged. This is necessary when traction to one or more wheels is likely to be lost.
- h. The parking brake warning light (Fig. 1-6 item 12) will illuminate if the parking brake is applied while the ignition is on.
- i. The trailer warning light (Fig. 1-6 item 13) provides an indication that the turn indicators on a towed trailer are functioning correctly. The light will flash simultaneously with the vehicle turn indicator warning light when a trailer is connected to the vehicle's NATO socket. When no trailer is used, the light will flash momentarily each time the combination switch is moved up or down. In addition, the trailer warning light will flash when the hazard warning switch is activated.
- j. The park light warning light (Fig. 1-6 item 15) indicates when the park lights have been switched on.
- k. The cold start warning light (Fig. 1-6 item 17) illuminates when the starter switch is in the glow plugs on position.

62. Coolant temperature gauge (Fig. 1-24 item 11)

Under normal running conditions, the temperature gauge needle should be within the green band. When operating in high ambient temperatures, with heavy loads or on steep grades at high altitudes, the operating temperature could rise. However, if the needle rises into the red band, the vehicle should be stopped and the cause determined.

63. Voltmeter (Fig. 1-24 item 12)

The voltmeter measures the vehicle system voltage. With the engine running above idle speed, the needle should be within the green band (12-14 volts). A reading above this in the high red band, which continues after approximately ten minutes, is too high and should be investigated. Similarly, a reading in the low red band which continues after approximately ten minutes, with no electrical load switched on, is too low and should also be investigated.

64. Air temperature control (Fig. 1-24 item 13)

The temperature control lever controls the temperature of the air from the heater unit. Moving the lever up in the direction of the blue arrow will cut off the heat, while moving the lever down toward the red arrow will increase the heat (see Fig. 1-7). Action is progressive between the two settings.

65. Air distribution control (Fig. 1-24 item 14)

The air distribution control lever controls the direction of air flow as follows (see Fig. 1-7):

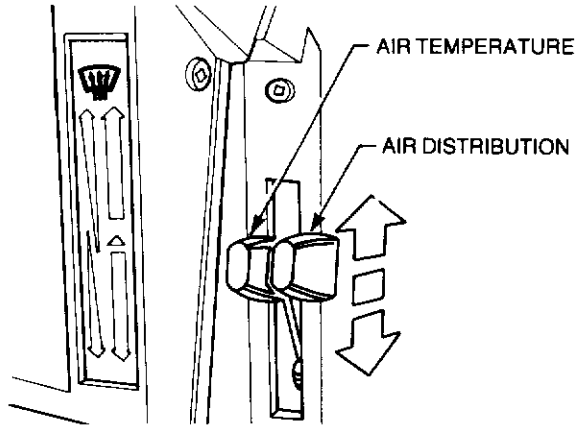

Figure 1-7 Air temperature and distribution controls

- a. With the lever in the upper position, all air is directed to the windscreen via the demister vents.
- b. With the lever in the mid position, air is directed to the foot level vents as well as the windscreen.
- c. With the lever in the lower position, the air is directed to the foot level vents although a certain amount of air will continue to pass through the demister vents to the windscreen.

66. Windscreen washer and wiper switch (Fig. 1-24 item 15)

The windscreen washer and wiper switch is a five-position switch, which only operates when the ignition is on. Switch operation is as follows (Fig. 1-8):

- a. With the switch in the upper position (A), fast wiper action is achieved.

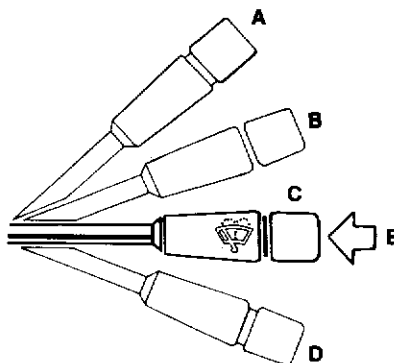

Figure 1-8 Windscreen washer and wiper control

- b. With the switch in the second position (B), slow wiper action is achieved.
- c. With the switch in the third position (C), the wipers are off.
- d. With the switch in the lower position (D), the wipers will operate at the slow speed until the switch is released.
- e. Pushing the switch knob inward (E) will activate the windscreen washer, which will spray water on the windscreen until the knob is released. This can be achieved with the switch on or off.

67. Hazard warning switch (Fig. 1-24 Item 16)

The hazard warning switch is a two-position rocker action switch. By pressing the lower section of the switch, both the left and right hand turn indicators, together with the side repeaters, flash simultaneously. A globe in the switch also illuminates to indicate that the switch is on. In addition, the trailer warning light will flash when the hazard warning switch is activated. Pressing the upper section of the switch turns the hazard warning lights off (see Fig. 1-9). Hazard warning lights will not function during blackout conditions.

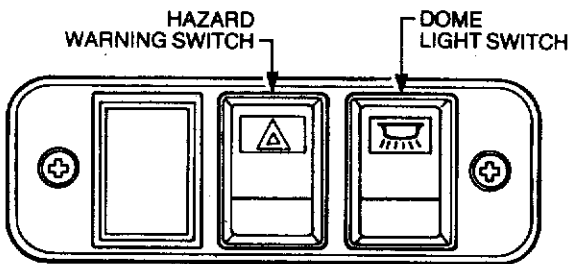

Figure 1-9 Hazard warning and cab dome light switches

68. Cab dome light switch (Fig. 1-24 Item 16)

The cab dome light switch is a two-position rocker action switch. Pressing the lower section of the switch turns the dome light on and pressing the upper section of the switch turns the dome light off (see Fig. 1-9). The dome light will not function during blackout conditions.

69. Hand throttle (Fig. 1-24 Item 17)

The hand throttle control can be used to over-ride the accelerator pedal to set engine speed. To utilize the hand throttle, first set the engine speed with the accelerator then pull out the hand throttle control and turn it to lock it in position. The accelerator will over-ride the hand throttle setting when increasing the engine speed. However, when the accelerator is released, the engine will return to the speed set by the hand throttle. To

release the hand throttle, turn the knob and push the control fully down to the closed position.

70. Accelerator pedal (Fig. 1-24 item 18)

The accelerator pedal controls the engine speed via the accelerator cable. Depress the pedal to increase engine speed.

71. Foot brake pedal (Fig. 1-24 item 19)

The foot brake pedal controls the application of the service brakes to all four wheels. Depress the pedal progressively to apply increased braking pressure.

72. Starter switch (Fig. 1-24 item 20)

The starter switch is a four-position switch, providing control over the ignition, glow plugs and starter motor. The switch is turned clockwise to activate the vehicle electrical system.

73. Main lighting switch (Fig. 1-24 item 21)

The main lighting switch is a three-position switch, providing control over the lighting as follows (see Fig. 1-10):

- a. With the switch pulled toward the driver, all lights will be off.
- b. With the switch in the centre position, the park lights will be illuminated.
- c. With the switch pushed away from the driver, both the main and park lights will be illuminated.

74. The main lighting switch will not function during blackout conditions.

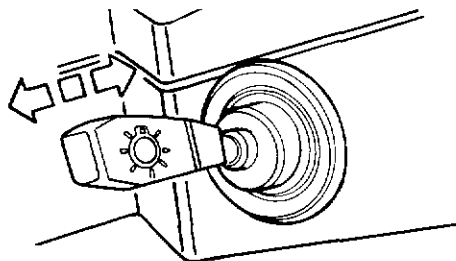

Figure 1-10 Main lighting switch

75. Winch/PTO control (Fig. 1-24 item 22)

The winch/PTO control is a push-pull cable which provides control over the PTO dog-clutch for winch drive. Pull the control handle out to engage the dog-clutch or push the handle in to disengage the dog-clutch.

76. Clutch pedal (Fig. 1-24 item 23)

Depress the clutch pedal to disengage the clutch.

77. Bonnet release (Fig. 1-24 Item 24)

The bonnet release is located to the left of the steering column, and by pulling the handle, the bonnet catch will release. From the front of the vehicle, lift the safety catch lever and raise the bonnet. Pull the support stay forward to secure the bonnet in the open position. The bonnet safety catch is illustrated in Fig. 1-11.

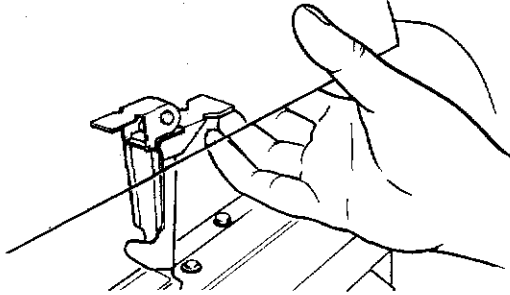

Figure 1-11 Bonnet safety catch

78. Parking brake lever (Fig. 1-24 item 25)

The parking brake is applied by pulling the lever back. To release the brake, pull the lever slightly back, depress the release button and push the lever down. Application of the parking brake will illuminate a warning light on the instrument panel.

79. Gear lever (Fig. 1-24 Item 26)

The gear lever is used to manually change the gear ratios in the transmission. The gear change pattern is illustrated in Fig. 1-12.

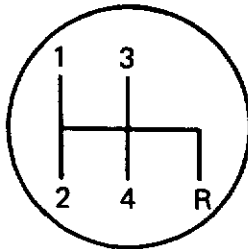

Figure 1-12 Gear change pattern

80. Transfer case shift lever (Fig. 1-24 Item 27)

The transfer case shift lever provides the manual selection of high or low gear ratios as required. The ratio shift pattern is illustrated in Fig. 1-13.

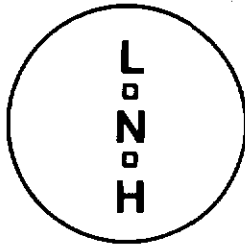

Figure 1-13 Transfer case shift pattern

81. Fuse box (Fig. 1-24 item 28)

Removing the fuse box cover allows access to the fuses. The location of each fuse is provided by the decals as shown in Fig. 1-14.

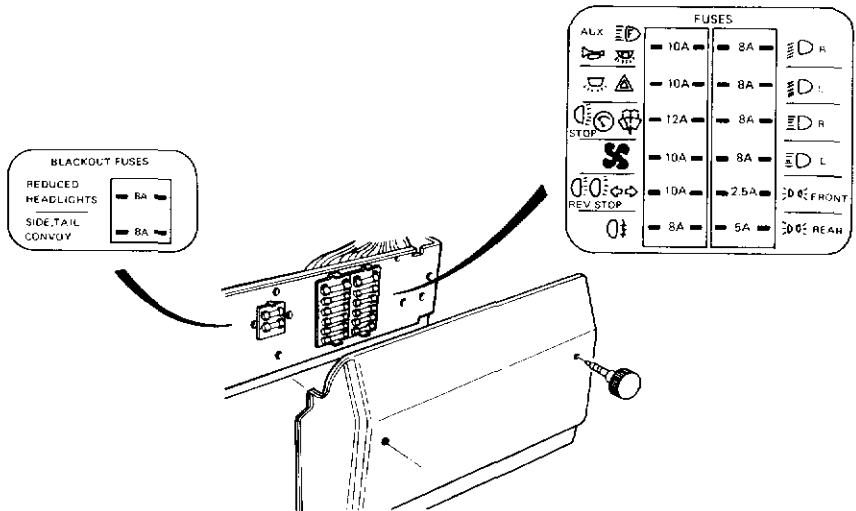

Figure 1-14 Fuses

82. The stop/start control motor is protected by a 10 amp fuse located under the bonnet to the side of the brake master cylinder.

83. Map reading light (Fig. 1-24 item 29)

The map reading light switch is located on the end of the light unit. The light can only be utilized when the ignition is on.

Cabin seating (Fig. 1-15)

84. The cabin seating is adjustable as illustrated in Fig. 1-15. The passenger's seat cushion must be removed to gain access to the battery.

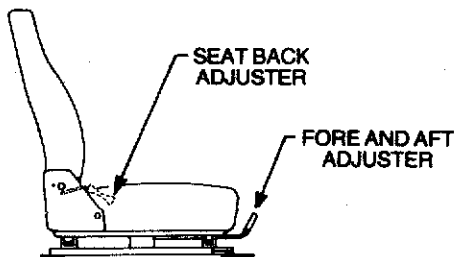

Figure 1-15 Seat adjustment

Body and chassis fittings

85. Vehicle body construction

The frame consists of two parallel steel box-section chassis rails held in position by five crossmembers. The frame is galvanized to prevent the formation of rust. The body consists of pressed aluminium panels which make up the engine compartment, the cabin and the rear cargo tray. The tray is fitted with a hinged tailgate and bench seating, which has removable cushion covers. Two roll bars are fitted over the tray area and these also act as support bows for the canvas canopy.

86. Stowage

A stowage bin is provided in each side of the rear body section, behind the rear wheels. These bins are lockable and the key is located in a canvas pocket secured to the driver's door.

87. Jerrican stowage

Two jerricans can be stowed at the rear of the vehicle, one on each side of the tailgate.

88. Rifle clips and butt boxes

Facilities for mounting two rifles are provided between the two seats in the cabin.

89. Fire extinguisher

A 1.5 kg BCF fire extinguisher is fitted on the cabin rear bulkhead, between the seats.

90. De-ditching tools

The de-ditching tools are mounted in brackets fitted to the bonnet. The tools comprise one axe, one shovel and one pick with handle.

91. Spare wheel stowage and lowering assembly

The spare wheel is stowed under the vehicle behind the rear axle and secured by a chain. The wheel is lowered from the stowed position by using the wheel brace inserted through the hole in the left hand rear mudguard, and operating the spare wheel winch (see Fig. 1-16). The spare

wheel is positively locked in the travel position when resistance is felt. The wheel is lowered by rotating the wheel brace in a counter-clockwise direction, which over-rides the locking cam.

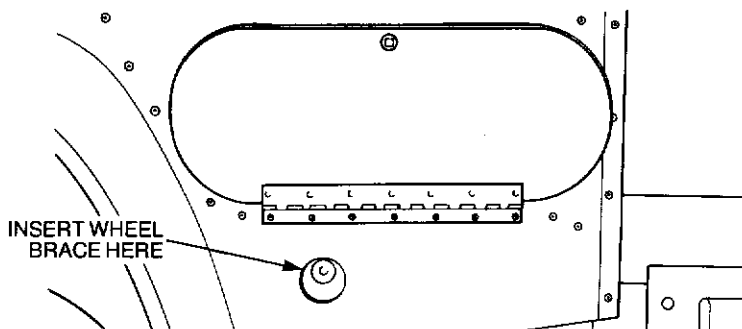

Figure 1-16 Spare wheel lowering

92. Electrical trailer connection socket

A 12-pin NATO trailer connection socket is fitted to the rear of the vehicle to the left of the towing pintle.

93. Towing pintle

An approved towing pintle is fitted to the rear of the vehicle.

94. Seat belts

Inertia reel seat belts are fitted for the cabin seats. The upper anchorage point for the seat belts is the foremost canopy bow. If the canopy bows are to be removed, the seat belt upper retaining bolts are to be removed and the belts secured to the lower anchorage points (see Fig. 1-17).

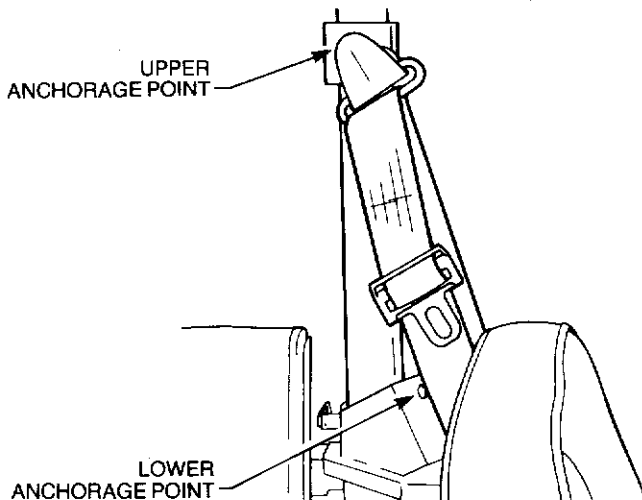

Figure 1-17 Seat belt anchorage

95. Rear vision mirrors

The external rear vision mirrors are hinged to fold back (inward) when knocked or bumped, thus reducing damage during cross-country operations.

96. Vehicle nomenclature plate (Fig. 1-18)

The vehicle manufacturer's identification number is stamped on a plate that is riveted to the passenger's seat box. The identification number is also stamped on the right hand side of the chassis, forward of the spring mounting turret.

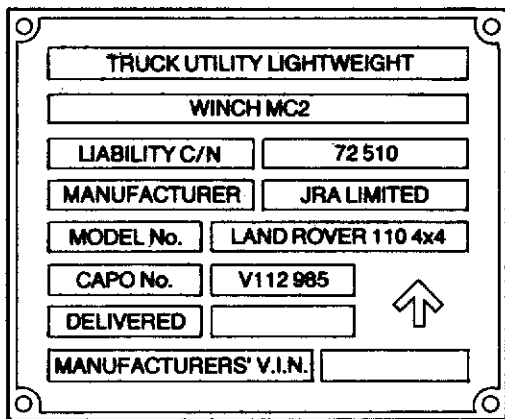

Figure 1-18 Vehicle nomenclature plate

97. Servicing data plate (Fig. 1-19)

The vehicle servicing data plate is riveted to the passenger's seat box, adjacent to the vehicle nomenclature plate.

NOTE

See EMEI VEH G 109 for approved lubricants.

SERVICING DATA				HYG 3002
COLD TYRE PRESSURES (kPa)		HIGHWAY	CROSS-COUNTRY	SAND
	FRONT	250	200	150
	REAR	350	275	225
LUBRICATION — NORMAL OR TROPICAL TEMPERATURES				
ENGINE	OMD-115	MASTER CYL.	OX (AUST) 8	
GEARBOX	OMD-115	MANUAL STG. BOX	OEP-220	
TRANSFER BOX	CASTROL FMX	POWER STG. BOX	OX46 or OX 47	
POWER TAKE-OFF	CASTROL FMX	LUBE. NIPPLES	XG-274	
AXLES	OEP-220	WINCH	OEP-220	
SWIVEL PIN H'SING	OEP-220			
ELECTRICAL — 12 VOLT NEGATIVE TO EARTH SYSTEM				

Figure 1-19 Servicing data and tyre pressure plate

98. Shipping data plate (Fig. 1-20)

The shipping data plate is riveted to the passenger's seat box just below the servicing data plate.

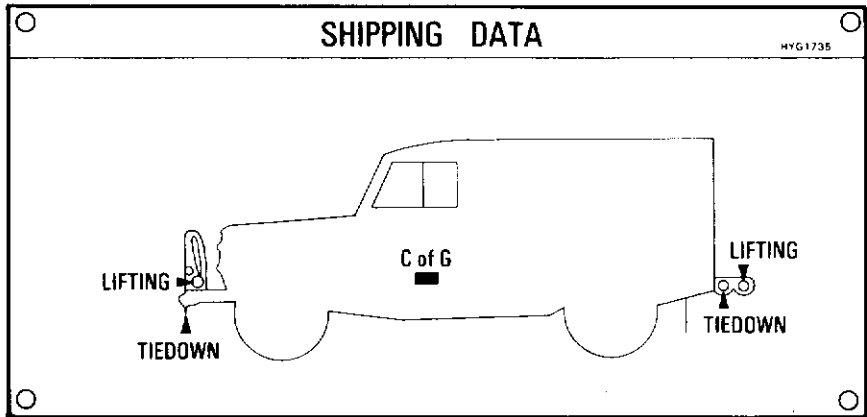

Figure 1-20 Shipping data plate

99. Towing and dyno test data plate (Fig. 1-21)

The towing and dyno test data plate is riveted to the driver's seat box. See para. 235 for propeller shaft removal precautions.

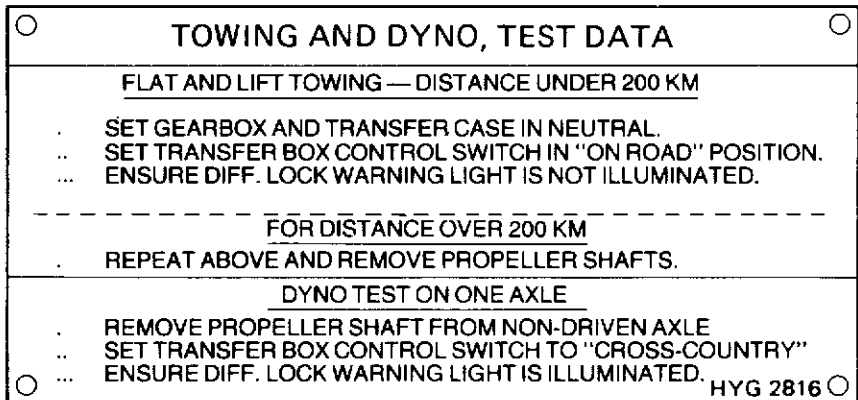

Figure 1-21 Towing and dyno test data plate

100. Jacking plate (Fig. 1-22)

A jacking plate is fitted to the stowage area lid as well as to the jack itself.

JACKING PROCEDURE		HYG 1764
DUE TO THE FITMENT OF A TRANSMISSION HANDBRAKE TO THIS VEHICLE, THE JACKING PROCEDURE MUST BE FOLLOWED BEFORE JACKING ANY WHEEL CLEAR OF THE GROUND.		
<ol style="list-style-type: none">1. APPLY HANDBRAKE.2. ENGAGE DIFFERENTIAL LOCK (WARNING LIGHT WILL ILLUMINATE).3. SELECT 1ST GEAR — LOW RANGE.4. CHOCK BOTH SIDES OF WHEEL FURTHEST FROM WHEEL BEING RAISED.5. SLACKEN WHEEL NUTS (5).6. FRONT WHEELS: POSITION JACK UNDER AXLE CASING IMMEDIATELY BELOW ROAD SPRING BETWEEN END FLANGE AND SUSPENSION BRACKET. REAR WHEELS: POSITION JACK UNDER AXLE CASING IMMEDIATELY BELOW ROAD SPRING NEAR DAMPER.7. REPLACE WHEEL AND TIGHTEN NUTS.8. LOWER VEHICLE.9. TORQUE NUTS: 100–115 Nm (75–85 lb.ft).10. DISENGAGE DIFFERENTIAL LOCK BEFORE MOVING OFF.		

Figure 1-22 Jacking procedure plate

101. Winch operation decal (Fig. 1-23)

A winch operation decal is affixed to the fuse box lid.

WINCH OPERATING INSTRUCTIONS			
1. SWITCH THE ENGINE OFF.	4. PUSH THE DOG-CLUTCH LEVER OUTBOARD, TURNING THE WINCH DRUM BY HAND TO ENSURE THAT THE DOG-CLUTCH HAS ENGAGED.	7. PULL OUT THE WINCH PTO CONTROL IN THE SEATBASE TO ENGAGE THE WINCH DRIVE.	10. SELECT NEUTRAL GEAR IN THE GEARBOX AND PUSH IN THE PTO CONTROL TO DISENGAGE THE WINCH DRIVE.
2. SET THE WINCH DOG-CLUTCH LEVER VERTICALLY (DOG-CLUTCH DISENGAGED) AND REEL OUT THE CABLE.	5. SET THE TRANSFER CASE CONTROL LEVER IN ITS NEUTRAL POSITION.	8. SLOWLY RELEASE THE CLUTCH PEDAL TO WIND IN THE WINCH CABLE.	11. DRIVE THE VEHICLE FORWARD TO SLACKEN THE WINCH CABLE.
3. ATTACH THE CABLE TO THE SELECTED ANCHOR POINT.	6. START THE ENGINE, DEPRESS THE CLUTCH PEDAL AND SELECT A LOW FORWARD GEAR.	9. DEPRESS THE CLUTCH PEDAL TO STOP THE WINCH (THE WORM GEARING WILL ENSURE THAT THE CABLE LOAD IS HELD).	12. DISENGAGE THE WINCH DOG-CLUTCH BY SETTING THE DOG-CLUTCH LEVER VERTICALLY.
DO NOT DISENGAGE THE WINCH DOG-CLUTCH UNDER LOAD DO NOT HAVE LESS THAN FOUR WRAPS OF CABLE ON THE DRUM DO NOT TRAVEL WITH THE WINCH ENGAGED		REFER TO THE VEHICLE HANDBOOK FOR MORE DETAILED INSTRUCTIONS	

Figure 1-23 Winch operation decal

102. Centre of gravity (C of G) designation plate

A "C of G" plate designating the longitudinal point of balance of the unladen vehicle is fitted to the left hand sill panel. See Fig. 1-3 for C of G dimensions.

103. Unit/formation signs

Four unit/formation sign holders are fitted to the vehicle. Two are riveted just below the head lights and the other two are riveted to the tailgate.

104. Bridge classification sign

Due to the size and weight of this vehicle, no bridge classification sign is fitted.

105. Camouflage lashing points

Three lashing points are provided on each side of the rear body for securing camouflage equipment.

NOTE

These lashing points are not to be subjected to high tension loadings.



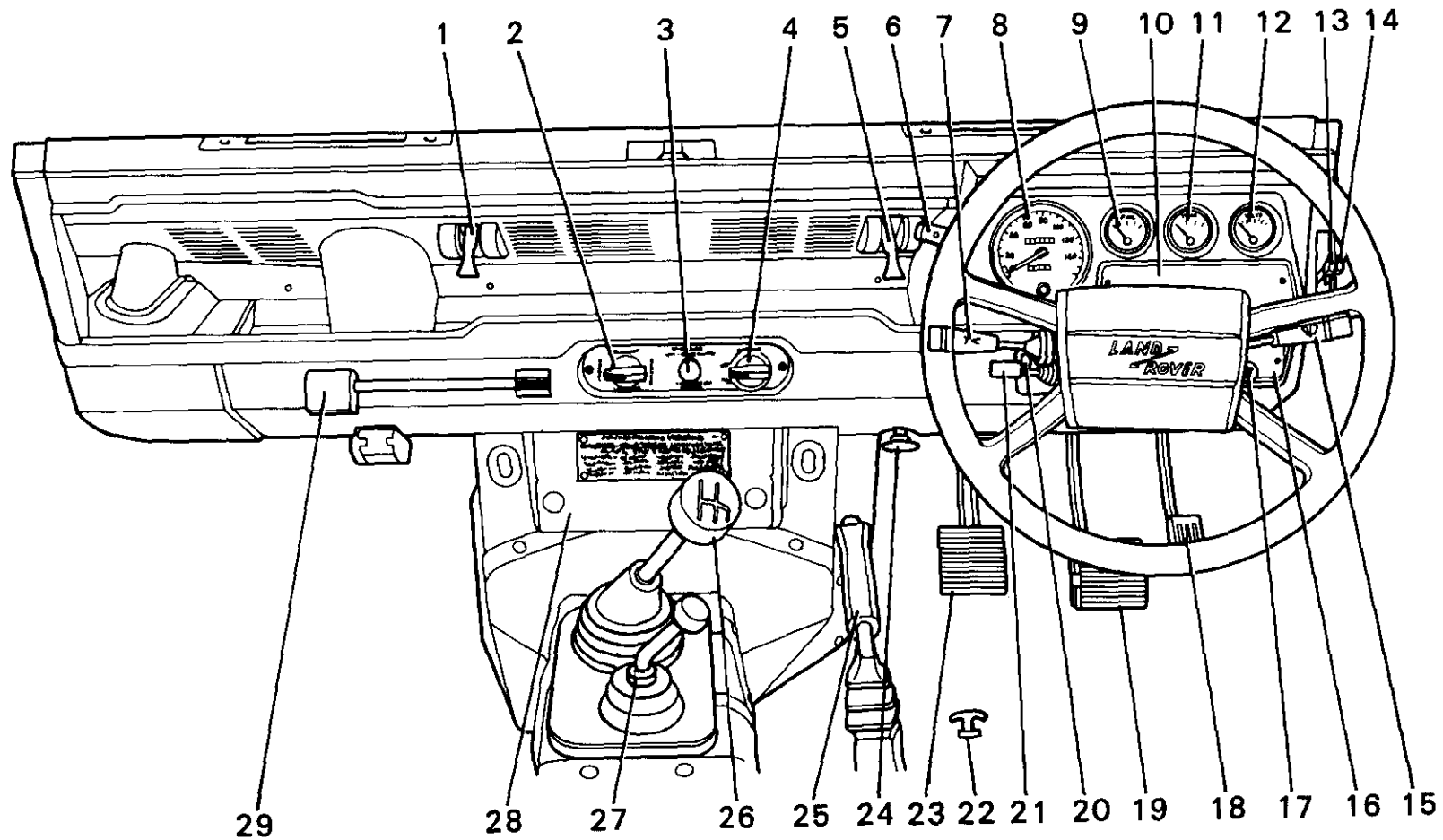

1. Ventilator control
2. Lighting control
3. Transfer case control
4. Panel light dimmer control
5. Ventilator control
6. Heater fan control
7. Combination switch
8. Speedometer
9. Fuel gauge
10. Warning light cluster

11. Coolant temperature gauge
12. Voltmeter
13. Air temperature control
14. Air distribution control
15. Windscreen washer and wiper switch
16. Hazard warning and interior lighting switches
17. Hand throttle
18. Accelerator pedal
19. Foot brake pedal
20. Starter switch

21. Main lighting switch
22. Winch/PTO control
23. Clutch pedal
24. Bonnet release
25. Parking brake lever
26. Gear lever
27. Transfer case shift lever
28. Fuse box
29. Map reading light

Figure 1-24 Instruments, electrical accessories and controls



CHAPTER 2

OPERATING INSTRUCTIONS

SECTION 1 — WARRANTY AND REPAIR

SECTION 2 — VEHICLE OPERATION

SECTION 1

WARRANTY AND REPAIR

Warranty Provision

201. The Contractor (JRA Limited) accepts responsibility for warranty in respect to the whole vehicle (except GFE items other than the mounting of such items) for a period of 12 months or 20 000 km, whichever occurs first from the time of issue of vehicle to user unit. Where vehicles are delivered to supply depots for extended storage, the depot becomes the user unit.

202. Where a vehicle is delivered into storage, provision is made for the warranty to be suspended for up to two years. Should the vehicle enter service during the two year period, then a pro-rata warranty applies in accordance with Table 2-1.

Table 2-1 Pro-rata warranty

Time of Withdrawal from Storage (measured from day of delivery into storage)	Period of Warranty after Withdrawal from Storage	
	Distance (km)	Time (mths)
First day of 1st month — last day of 3rd month	20 000	11
First day of 4th month — last day of 6th month	18 000	10
First day of 7th month — last day of 9th month	16 000	9
First day of 10th month — last day of 12th month	14 000	8
First day of 13th month — last day of 15th month	12 000	7
First day of 16th month — last day of 18th month	10 000	6
First day of 19th month — last day of 21st month	8 000	5
First day of 22nd month — last day of 24th month	6 000	4*
First day of 25th month — last day of 27th month	3 000	3*

***NOTE:** The warranty finally expires after twenty-seven (27) months irrespective of any outstanding distance or time pro-rata warranty.

Special Provisions

203. The warranty shall not apply where failure arises from:

- Vehicle not being maintained in accordance with User Handbook or EMEI manuals.
- EMEI storage procedures not being effectively applied.
- Misuse or neglect.
- The fitting of non-genuine parts and where it is mutually agreed as a contributing factor.

- e. The use of equipment not normally or reasonably associated with the operation of the supplies.
- f. Supplies that have been altered in form or function without consultation with and approval of the Contractor.
- g. Any part or parts of which the specification has been altered by the Commonwealth without the Contractor's approval.
- h. Any part or parts from which the identification marks or numbers have been altered or removed by the Commonwealth.
- i. Repairs which involved or resulted from either directly or indirectly the use of non-genuine parts.
- j. Incorrect tuning, adjustments or maintenance operations which are associated with periodic servicing requirements.
- k. Parts or equipment which have not been supplied by the Contractor or by a supplier approved by the Contractor and any problems which may arise, either directly or indirectly from the fitment of such equipment.
- l. The consequences of the supplies having been repaired by a non-approved repairer. For the purpose of this clause, approved repairer shall include Army vehicle maintenance personnel.

Application of Warranty

204. The application of the warranty will be by repair or replacement of the defective component at no cost to the Commonwealth.

205. Provision is made for warranty repairs to be carried out by JRA Limited authorised Land Rover dealers and a list of such dealers is included in this publication.

206. However, if for reasons of distance, location etc., it is not practical to have the necessary repairs carried out by a JRA Limited authorised Land Rover dealer, then an Army tradesman is approved to carry out the repair. This procedure should be adopted in the case of emergency or essential repairs only (e.g. for safety, prevention of further damage or an operational requirement).

207. In such circumstances, JRA Limited will reimburse the Army for parts used at cost and labour at standard repair times and the prevailing Land Rover dealer warranty hourly labour rate.

208. The information required to be documented by the Army unit in such circumstances is:

- a. Identify the vehicle by chassis and or Army registration number.
- b. Date vehicle entered service (if known).

- c. Current odometer reading.
- d. Nature of failure (brief explanation).
- e. Nature of repair necessary.
- f. Parts replaced by designation and part number.
- g. Time taken or Standard Repair Time (SRT) and operation number (refer to EMEI VEH A119-22).
- h. If parts were procured through a Land Rover dealer, then documentation identifying purchase and price paid.
- i. JRA Authority Number (if applicable).

209. The procedure for submitting a claim to JRA Limited to obtain reimbursement is defined in EMEI VEH A119-22.

Prior Consultation

210. Where a vehicle is presented to an authorised JRA Limited Land Rover dealer for warranty repairs, the Army need not be concerned as the dealer has adequate authority to deal with most situations and the necessary procedure to obtain authority in the case of major repairs.

211. In circumstances where the Army are themselves undertaking a warranty repair, this may proceed without authority provided the estimated total material and labour cost is less than \$500. If the cost is estimated to be in excess of \$500, then the appropriate JRA Limited State Office listed in Table 2-2 should be contacted for authority and guidance.

212. The person making the contact should have the following information available:

- a. Vehicle chassis and Army registration number.
- b. Date in service (if known).
- c. Current odometer reading.
- d. Knowledge of the problem encountered.

Continuance of Warranty Following a Warranty Repair

213. Any supplies corrected or furnished by way of replacement under warranty claim, whether it be an initial equipment supply or replacement part, will enjoy the balance of any existing warranty.

Warranty on Replacement Parts and MSI's

214. Except when fitted in the execution of a warranty repair, replacement parts and MSI's enjoy the same warranty as the vehicle and in general terms as applicable the same special provisions apply (see para. 203).

Table 2-2 JRA State Offices

JRA State Offices	Telephone	Telex	Facsimile
N.S.W. Cnr Heathcote Rd. and Church St., LIVERPOOL SW 2170	(02) 600 1333	25375	(02) 602 1759
VIC. 52 Glenvale Cres. MULGRAVE VIC 3170	Service (03) 562 0299 Parts (03) 562 0300	30372	(03) 562 0221
QLD. Cnr St Pauls Terr. and Brunswick St., FORTITUDE VALLEY QLD 4006	(07) 854 1599	42311	(07) 52 3776
S.A. 164 Fullerton Rd., DULWICH S.A. 5065	(08) 332 7799	—	(08) 364 0456
W.A. 127 Melville Pde., COMO W.A. 6152	(09) 368 1477	92413	(09) 368 1260

List of Agents

215. Table 2-3 details the Land Rover dealers throughout Australia and their repair level capability.

Table 2-3 Land Rover dealers

Agent	Repair Level
Queensland (1 MD)	
Atherton Aldridge Motors Pty Ltd (070- 91 1468) 18 Mabel Street Atherton QLD 4883	Unit
Bowen Hills UK Motors Pty Ltd (07- 253 9444) 123 Campbell Street Bowen Hills QLD 4006	Base

Table 2-3 Land Rover dealers (cont'd)

Agent	Repair Level
Bundaberg Alan Powell Jaguar Rover (071- 72 9666) 43 Bourbong Street Bundaberg QLD 4670	Field
Burketown Nowland Engineering (011- 077- 45 5107 via exchange) Gregory Street Burketown QLD 4830	Field
Caloundra Pacific Jaguar Rover (071- 91 1344) 32 Bowman Road Caloundra QLD 4551	Base
Cairns John Broadley Jaguar Rover (070- 51 1188) 94 McLeod Street Cairns QLD 4870	Base
Cooktown Peninsula Auto Services (070- 69 5327) 10 Boundary Street, Cooktown QLD 4871 Phil Witheridge (Prop.)	Field
Gympie Gympie Carworld (071- 82 2822) 69 Monkland Street Gympie QLD 4570	Field
Mackay Carlisle Motors Pty Ltd (079- 57 2971) 36 Gregory Street Mackay QLD 4740	Base
Maryborough Jack Casey Motorworld (071- 21 2545) 103 Lennox Street Maryborough QLD 4650	Base

Table 2-3 Land Rover dealers (cont'd)

Agent	Repair Level
Mount Gravatt Keema Jaguar Rover (07- 343 5888) 1532 Logan Road Mount Gravatt QLD 4132	Base
Mount Isa Ian Bryan Ford (077- 43 4622) 59 West Street Mount Isa QLD 4825	Field
Normanton Top Service Station (077- 45 1261 STD) (077- 40 7777 via exchange) Landsborough Street Normanton QLD 4890	Field
Rockhampton Citimotors (079- 27 6866) 66 Gladstone Road Rockhampton QLD 4700	Base
Southport Southport Motors (075- 32 1833) 121 Scarborough Street Southport QLD 4215	Base
Toowoomba Allan Flohr Jaguar Rover (076- 34 3233) Cnr James and Anzac Avenues Toowoomba QLD 4350	Base
Townsville Tony Ireland Jaguar Rover (077- 71 6855) 87 Charters Towers Road Townsville QLD 4810	Base
Virginia Grand Prix Nominees Pty Ltd (07- 265 1000) Cnr. Robinson Road and Hadley Street Virginia QLD 4014	Base

Table 2-3 Land Rover dealers (cont'd)

Agent	Repair Level
Weipa Weipa Servicentre (070- 69 7277) Boundary Road Weipa QLD 4874	Field
New South Wales (2 MD)	
Albury Albury Motors (060- 21 2188) 475 Olive Street Albury NSW 2640	Base
Armidale K.G. Motors Pty Ltd (067- 72 3580) 121 Marsh Street Armidale NSW 2350	Field
Arncliffe Purnell Motors (02- 59 0241) 139 Princes Highway Arncliffe NSW 2205	Base
Artarmon New Rowley Motors (02- 436 0231) 393 Pacific Highway Artarmon NSW 2064	Base
Bega Tarra Rover (0649- 2 1666) 151 Auckland Street Bega NSW 2550	Field
Bombala Lomas' Garage (0648- 8 3311) 80-86 Maybe Street Bombala NSW 2553	Field
Broken Hill Advance Motors (080-7180) 96 Gypsum Street Broken Hill NSW 2880	Field

Table 2-3 Land Rover dealers (cont'd)

Agent	Repair Level
Carlton Lindsay Johnstone (02- 546 3211) 57 Planthurst Road Carlton NSW 2218	Base
Casino Capitol Car Sales (066- 62 1477) Centre Street Casino NSW 2470	Unit
Coffs Harbour Autocare (066- 52 1422) 115 High Street Coffs Harbour NSW 2450	Field
Dubbo Langdon and Bartley (068- 82 6677) Cnr Bourke and Edwin Streets North Dubbo NSW 2830	Field
Dungog O.T. and S.A. Rumbel (049- 92 1486) 282 Dowling Street Dungog NSW 2420	Field
Gosford Regal Motors (043- 25 0238) 358 Mann Street Gosford NSW 2250	Base
Hamilton Regal Motors (049- 62 1011) 67 Tudor Street Hamilton NSW 2303	Base
Homebush Asquith and Johnstone Pty Ltd (02- 764 1777) 145 Parramatta Road Homebush NSW 2140	Base

Table 2-3 Land Rover dealers (cont'd)

Agent	Repair Level
Lismore John Chant Motors Pty Ltd (066- 21 2601) Cnr Ballina and Brewster Streets Lismore NSW 2480	Unit
Moorebank Wrendco Automotive Repairs (02- 600 6537) 8 Seton Road Moorebank NSW 2170	Base
Murwillumbah Youngblutt Car Sales Pty Ltd (066- 72 1963) 389 Pacific Highway Murwillumbah NSW 2480	Field
Nowra Maconachie Motors (044- 210 9222) Kingshorn Street Nowra NSW 2540	Field
Penshurst Garthon Motors (02- 579 4388) 492 Forest Road Penshurst NSW 2222	Base
Singleton R. and E. Teasdale Pty Ltd (065- 72 1655) 64 George Street Singleton NSW 2330	Field
Sydney (City) City Automobiles (02- 33 0678) 123 William Street Sydney NSW 2000	Base
Toronto Triggs Motors (049- 59 2122) 36 Victory Parade Toronto NSW 2283	Base

Table 2-3 Land Rover dealers (cont'd)

Agent	Repair Level
Wagga Wagga Jupiter Motors Pty Ltd (069- 21 6555) 20 Edwood Street Wagga Wagga NSW 2650	Field
Wauchope Wauchope Motors (065- 85 3766) High Street Wauchope NSW 2446	Field
Victoria (3 MD)	
Ballarat Gordon Motors Pty Ltd (053- 39 5022) 1041-1043 Howitt Street Wendouree VIC 3355	Base
Bendigo Provincial Motors Div. of Ansett Transport — Operations (054- 48 4433) Midland Highway, Epsom Bendigo VIC 3551	Field
Brighton Lane Jaguar Rover Pty Ltd (03- 557 2875) 771 Nepean Highway Brighton VIC 3187	Base
Corryong Mildren and Coysh Pty Ltd (060- 76 1151) Cnr Anzac and Towong Roads Corryong VIC 3707	Field
Frankston Peninsula Prestige Cars Pty Ltd (03- 781 2022) 130 Dandenong Road Frankston VIC 3199	Base

Table 2-3 Land Rover dealers (cont'd)

Agent	Repair Level
Geelong Peck and Stokes Motors (052- 21 2111) 31-37 Gordon Avenue Geelong VIC 3218	Field
Malvern ULR Sales and Service (03- 822 0211) 1339 High Street Malvern VIC 3144	Base
Mansfield Berry and O'Halloran (057- 75 2375) 121-123 High Street Mansfield VIC 3722	Field
Mildura Syd Mills Motors Pty Ltd (050- 23 0261) 115 Eight Street Mildura VIC 3500	Field
Morwell Massaro Motors Pty Ltd (051- 34 1422) 497 Princes Highway Morwell VIC 3840	Field
Nunawading Whitehorse Motors (03- 878 6677) 296 Whitehorse Road Nunawading VIC 3131	Base
South Australia (4 MD)	
Bordertown Inglis Motors (087- 52 1577) South Terrace Bordertown S.A. 5268	Field
Medindie Taylors of Medindie (08- 344 6921) 51 Main North Road Medindie S.A. 5081	Base

Table 2-3 Land Rover dealers (cont'd)

Agent	Repair Level
<p>Millicent Alex Bohner Motors Pty Ltd (087- 33 2022) 44 Mount Gambier Road Millicent S.A. 5280</p>	Base
<p>Mount Gambier Hopegoods Garage (087- 25 5322) Cnr Sturt and Ferrers Street Mount Gambier S.A. 5290</p>	Unit
<p>Western Australia (5 MD) Broome Shinju Motors (091- 92 1250) Walcott Street Broome W.A. 6725</p>	Field
<p>Bunbury Wallace Motors Pty Ltd (097- 21 4588) 72 Spencer Street Bunbury W.A. 6230</p>	Base
<p>Carnarvon Dellbar Motors (099- 41 1397) 60 Robinson Street Carnarvon W.A. 6701</p>	Field
<p>Derby Kimwest Motors (091- 91 1647) 44 Clarendon Street Derby W.A. 6728</p>	Field
<p>Esperance Ratten and Slater (090- 71 0133) Norsman Road Esperance W.A. 6450</p>	Field
<p>Katanning Wake's Garage (098- 21 1074) 27 Richardson Street Katanning W.A. 6317</p>	Field

Table 2-3 Land Rover dealers (cont'd)

Agent	Repair Level
Kununurra Norwest Diesel Service (091- 68 1195) Bloodwood Drive Kununurra W.A. 6743	Field
Manjimup Manjimup All Wheel Drive (097- 71 1535) Franklin Street Manjimup W.A. 6258	Field
Newman Bax Motor Service (091- 75 1791) Cnr Woodstock and Willis Streets Newman W.A. 6753	Field
Osborn Park Oxford Allenby Motors (09- 444 5999) 354 Scarborough Beach Road Osborn Park W.A. 6017	Base
Perth Winterfaulls Pty Ltd (09- 328 9333) 252 Aberdeen Street Perth W.A. 6000	Base
Port Hedland Shell Roadhouse (091- 73 1146) Wilson Street Port Hedland W.A. 6721	Field
Wyndham Branco BP Motors (091- 61 1305) Great Northern Highway Wyndham W.A. 6740	Unit

Table 2-3 Land Rover dealers (cont'd)

Agent	Repair Level
Northern Territory (6 MD)	
Alice Springs Sutton Motors (089 52 1334) 13 Smith Street Alice Springs N.T. 5750	Field
Darwin Port Darwin Motors Pty Ltd (089- 81 9444) 15 Stuart Highway Darwin N.T. 5790	Base
Katherine Agserv Industries (089- 72 1788) 441 Victoria Highway Katherine N.T. 5780	Field
Tasmania (7 MD)	
Hobart Terry Hickey Autos Pty Ltd (002- 34 9122) 167-171 Murray Street Hobart TAS 7000	Base
Launceston Davies Car Centre (003- 31 9422) Cnr. Wellington and Frederick Streets Launceston TAS 7250	Base
Australian Capital Territory	
National Capital Motors (062- 51 2600) Josephson Street Belconnen ACT 2617	Base

SECTION 2 VEHICLE OPERATION

216. General

Proper operation determines the service life and operating economy of the vehicle. This includes, careful driving, normal road speeds, reasonable rates of acceleration and braking and changing gears in a manner to avoid shock loading and labouring.

217. Before starting

Carry out a first parade service as detailed in Chapter 3 Section 1.

218. Before starting the engine

Ensure that the parking brake is applied. Depress the clutch pedal fully to disengage the clutch then move the gear lever to neutral.

219. Starting the engine

NOTE

The glow plugs need only be used to start the engine when the vehicle is operating continually in low ambient temperatures (below 5°C), and then for no longer than five seconds.

Depress the accelerator pedal approximately half way and hold the pedal in this position while turning the ignition switch clockwise to start the engine. As the switch is turned to the first position, the oil pressure, battery

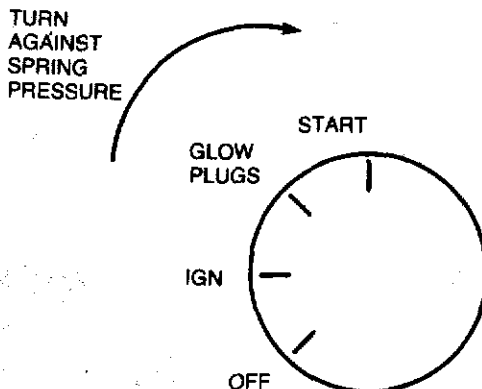

Figure 2-1 Starter switch positions

charge and parking brake warning lights will illuminate. In the next switch position the glow plug light illuminates, but do not hold the switch in this position unless cold operating conditions are experienced. Turn the switch fully to engage the starter motor, then release the switch and return the accelerator pedal to the idle position once the engine has started. All warning lights except the parking brake light should now be extinguished.

NOTE

Do not operate the starter motor continuously for longer than ten seconds without a pause.

220. Moving the vehicle

- a. With the engine operating, disengage the clutch by pushing the pedal to the floor. Select high ratio or low ratio on the transfer case shift lever, depending on the vehicle load and terrain.

NOTE

Changing from high to low or low to high ratio should only be attempted when the vehicle is stationary. Should difficulty be encountered when engaging high or low ratio, do not force the lever. With the engine running, engage a gear with the main gear lever and release the clutch momentarily, then return the main gear lever to neutral and try the transfer case shift lever again.

- b. Select first gear on the gear lever then release the parking brake. If the parking brake warning light does not extinguish, do not attempt to move the vehicle.
- c. Engage the clutch smoothly by releasing the clutch pedal and simultaneously depressing the accelerator pedal the amount necessary for the engine to move the load.

NOTE

Never allow the foot to RIDE the clutch pedal with the clutch engaged. This causes premature clutch wear.

- d. As the vehicle gains speed, continue changing gear until cruising speed is achieved and the transmission is in the highest gear possible without labouring the engine.

Good driving habits

221. Engine temperature

Allow the engine to reach normal operating temperature before engaging in high speeds or hauling heavy loads.

WARNING

Should the engine become overheated, park the vehicle in a safe working area and allow the engine to cool before attempting repairs to, or refilling of, the cooling system.

222. Instruments

Glance at the instruments frequently. If a fault is indicated, assess the corrective action required and stop the vehicle as necessary.

223. Clutch

To avoid damage, engage the clutch with a smooth action. Do not RIDE the clutch.

224. Gear changing

Ensure that the correct gear is selected for the terrain, vehicle load and speed.

225. Braking

Avoid sudden stops. When stopping on slippery surfaces, smoothly apply and release the brakes alternately to prevent skidding. When slowing to a halt, leave the clutch engaged as long as possible to utilize the engine braking effect. Before descending steep slopes, select first gear, low ratio with the differential locked to provide maximum engine braking.

226. Stopping the engine

Allow the engine to return to the normal idle speed before turning the ignition off.

227. Parking

Use the parking brake when parking the vehicle. Check frequently to ensure that the brake is adjusted to lock and hold the vehicle when parked. Do not use the parking brake when the vehicle is in motion, except in an emergency. When parking on an incline, leave the vehicle in gear.

228. Fording

The maximum advisable fording depth is 500 mm. When fording is to be undertaken, ensure that the flywheel housing drain plug is securely fitted (see Fig. 2-2). If deep water is anticipated, loosen the fanbelt to prevent

damage to the fan or radiator, and saturation of the electrical system. Avoid excessive speed.

229. Once the crossing has been accomplished, drain the flywheel housing and tighten the fanbelt. Ensure that the brakes are dry and fully effective before proceeding.

NOTE

After fording, check the oil in the engine, transmission, transfer case and swivel pin housings for signs of water contamination. Change contaminated oils as soon as possible.

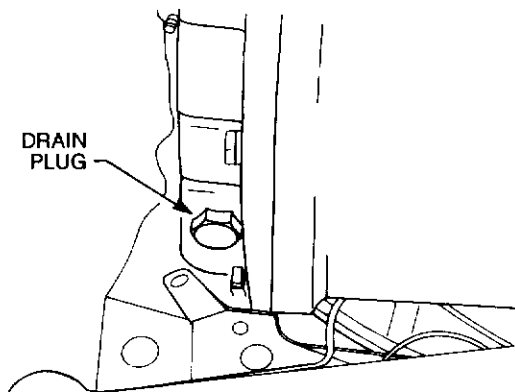

Figure 2-2 Flywheel housing drain

230. Cross-country driving

WARNING

Because of the excellent rough terrain characteristics of this vehicle, drivers are cautioned to maintain a safe speed for the conditions encountered, especially when towing a trailer or utilizing tyre chains.

The transfer case differential lock should be utilized for cross-country driving. When activated, the differential lock warning light will illuminate indicating that the dog clutch in the transfer case is fully engaged. Although the differential lock can be engaged while the vehicle is moving, no power should be applied to the transmission during this operation.

NOTE

Under some conditions, a slight delay may be experienced before the warning light illuminates. This is due to the time required for the dog clutch to align with its mating splines and become fully engaged.

- 231.** On reaching normal road conditions, the differential lock must be disengaged.

NOTE

Under some conditions, a slight delay may be experienced before the warning light extinguishes after the switch is pushed in. If the warning light does not extinguish, this indicates that the dog clutch is not fully disengaged. This is usually due to transmission wind-up which jams the dog clutch. If this occurs, the vehicle should be stopped and reversed a few metres to unwind the transmission. The warning light should now extinguish.

Changing a wheel

- 232.** To replace a flat tyre with the spare wheel, proceed as follows:
- a. Remove the hydraulic jack, handle and jack base plate, from the stowage bin.
 - b. Engage the differential lock and check that the differential lock warning light illuminates.

NOTE

If the vehicle has been stationary prior to changing the wheel, the differential lock may not engage when selected. In this case, it will be necessary to start the engine and engage a gear and release the clutch sufficiently to allow slight movement of the gears, until the warning light is illuminated. Switch off the engine.

- c. Ensure that the parking brake is applied and that the wheels are chocked.

WARNING

The parking brake acts on the transmission, not the rear wheels. The differential lock must be engaged and the wheels chocked to enable the vehicle to be raised safely.

- d. Engage first gear in the transmission and low range in the transfer case.
- e. Position the jack under the vehicle as follows:
 - (1) Front wheel. Position the jack so that when raised, it will engage with the front axle casing immediately below the coil spring, where it will locate between the flange at the end of the axle casing and the large bracket to which the front suspension members are mounted (see Fig. 2-3).

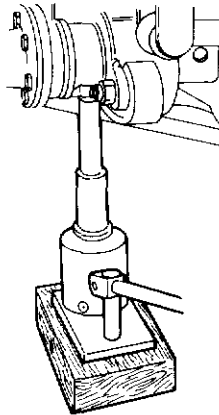

Figure 2-3 Jack position — front wheels

- (2) Rear wheel. Position the jack so that when raised, it will engage with the rear axle casing immediately below the coil spring and as close as possible to the shock absorber mounting bracket (see Fig. 2-4).

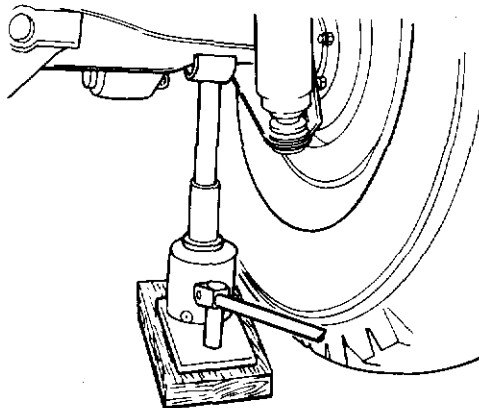

Figure 2-4 Jack position — rear wheels

- f. Before raising the vehicle, lower the spare wheel to the ground and remove it from under the vehicle, then using the wheel brace, initially slacken the nuts on the wheel to be removed.
- g. Jack up the appropriate corner of the vehicle. When the wheel is clear of the ground, remove the wheel nuts and lift off the wheel.
- h. Ensure that the wheel nuts and studs are clean then fit the spare wheel and secure with the wheel nuts. Tighten the wheel nuts.
- i. Lower the vehicle to the ground and torque the wheel nuts to 100–115 Nm (75–85 lb.ft) in the correct sequence (diagonally opposite). Use hand pressure only. Do not use foot pressure or extension tubes as this could overstress the wheel studs.
- j. Remove the jack and the wheel chocks then disengage the differential lock.

Canopy

233. To fit a canopy to the vehicle, proceed as follows:

- a. Ensure that the four latches above the windscreen are in the released position (see Fig. 2-5).

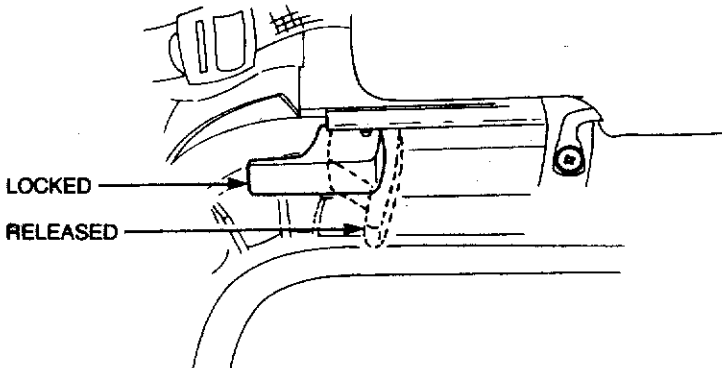

Figure 2-5 Canopy retaining latches

- b. Position the canopy over the cabin then insert the canopy leading edge between the windscreen frame and the clamping frame. Lightly clamp the canopy in each corner with the two outer latches.
- c. Roll the canopy back over the frame and align the canopy with the vehicle body.
- d. Secure the canopy leading edge with the four latches.

- e. Starting at the front of the canopy, secure all straps in the cabin area.
- f. Secure all straps in the cargo area starting with the B-pillar, then secure the lower edge of the canopy to the body panel hooks using the rope.
- g. Pull the canopy around the rear canopy bow and tie the ropes to the rear body tie hooks.
- h. Secure the two straps adjacent to the tailgate and lightly tension.

Windscreen lowering

234. To lower the windscreen, proceed as follows:

- a. Remove the wiper blades and arms. These are held onto the wiper motor shafts by spring clips.
- b. Remove the nut and washer from the captive bolt at the top of the windscreen on each side.
- c. Loosen the clamps at the bottom of the windscreen, then lower the windscreen onto the brackets on the bonnet.
- d. Secure the windscreen to the brackets with the straps provided.

Towing

235. The following precautions must be taken before towing:

- a. Set the transmission and transfer case to neutral.
- b. Set the transfer case control switch to the on-road position.
- c. Ensure that the differential lock warning light is extinguished.
- d. When the front propeller shaft is to be removed, the flange mounting bolts must be secured with nuts or wire to prevent damage to the transmission casing.

Winch operation

236. The following precautions must be observed:

WARNING

Always wear industrial gloves when handling steel wire rope. Do not use the hands to guide the rope on or off the drum when winching.

- a. The winch rope must be lubricated regularly and used correctly to maintain the rope in a serviceable and easy to handle condition.

- b. The winch rope should be wound tightly and evenly on the winch drum, otherwise pressure on the top layer will force the rope down between the lower layers, causing entanglements and serious damage could result.
 - c. Do not continue winching if a kink is noticed in the winch rope. Release the tension and remove the kink.
 - d. The winch rope should not be looped around a load or anchor point. Chain should be used for this purpose.
 - e. The winch rope should not be paid out under power except when circumstances offer no alternative.
 - f. Do not disengage the winch dog-clutch under load.
 - g. Do not leave less than four wraps of winch rope on the drum.
 - h. Do not travel with the winch engaged.
 - i. Do not use the winch rope for towing under any circumstances.
237. To release the winch rope manually:
- a. Ensure that the engine is switched OFF, then set the winch dog-clutch lever to the vertical position (see Fig. 2-6) to disengage the dog-clutch. Reel out the winch rope as required.

NOTE

Do not leave less than four wraps of winch rope on the drum.

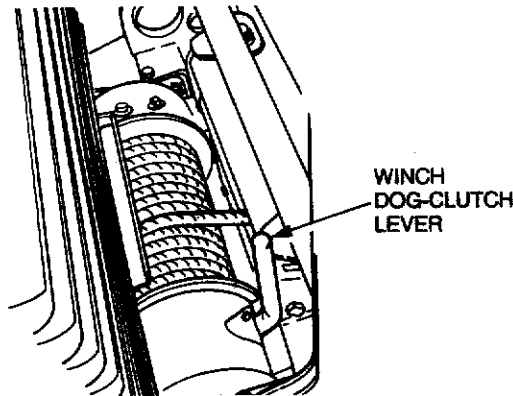

Figure 2-6 Winch dog-clutch operation

238. Attach the winch rope to the selected anchor point.

NOTE

The winch rope should not be looped around a load or anchor point. Use suitable chains for this purpose.

239. To winch out under power:

- a. Push the winch dog-clutch lever outward, while turning the winch drum by hand to ensure that the winch dog-clutch has engaged.
- b. Place the transfer case control lever to the neutral position, then start the engine.

NOTE

Ensure that a load is always applied to the winch rope when winching out.

- c. Depress the clutch pedal and select reverse gear, then pull out the winch/PTO control in the seat base (see Fig. 2-7) to engage the winch drive. Increase engine speed to approximately 1300 rpm then slowly release the clutch pedal to begin winding out the winch rope.

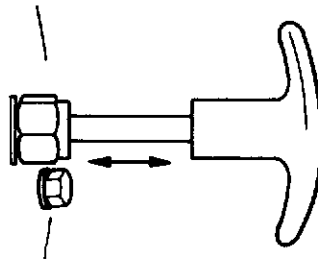

Figure 2-7 Winch/PTO control operation

- d. To stop the winch during operating procedures, depress the clutch pedal. The worm gearing will ensure that the winch load is held until winching is resumed.

240. Attach the winch rope to the selected anchor point.

NOTE

The winch rope should not be looped around a load or anchor point. Use suitable chains for this purpose.

241. To winch in:

- a. Push the winch dog-clutch lever outward, while turning the winch drum by hand to ensure that the winch dog-clutch has engaged.
- b. Place the transfer case control lever to the neutral position, then start the engine.

NOTE

Ensure that a load is always applied to the winch rope when winching in.

- c. Depress the clutch pedal and select a low forward gear, then pull out the winch/PTO control in the seat base (see Fig. 2-7) to engage the winch drive. Increase engine speed to approximately 1300 rpm then slowly release the clutch pedal to begin winding in the winch rope.
- d. To stop the winch during operating procedures, depress the clutch pedal. The worm gearing will ensure that the winch load is held until winching is resumed.

NOTE

1. The winch oil will overheat and rapidly lose its lubricating properties if the winch is used continuously at its maximum capacity. Under these circumstances, time should be allowed for the winch lubricant to cool before resuming winching. The maximum allowable temperature of the winch oil is 120°C, but operation below 100°C is preferable.

2. An automatically re-setting torque limiter is incorporated in the winch power take-off. This is pre-set to release at an input torque corresponding to the rated capacity of the winch, and will be indicated by a loud rattling sound from the transmission area. When this occurs, winching should immediately be stopped and the means found to reduce the winch rope load, for instance by relocating the rope anchor point. Extensive use of the power take-off with the torque limiter continuously released will cause excessive wear of the torque limiter, and will not assist in the winch operation.

242. On completion of the winching task:

- a. Depress the clutch pedal to stop the winch and allow the engine to idle.
- b. Place the transmission in neutral and push in the winch/PTO control to disengage the winch drive.
- c. Drive the vehicle forward to slacken the winch rope and remove the winch rope from the anchor point. Winch the remaining rope in under load, then secure the chain to the front of the vehicle.
- d. Disengage the winch dog-clutch by turning the dog-clutch lever to the vertical position.



CHAPTER 3

OPERATOR SERVICING

SECTION 1 — SERVICING

SECTION 2 — LUBRICATION

SECTION 1

SERVICING

First parade servicing

301. Before moving off with a loaded or unloaded vehicle, carry out the inspections, checks and tests as laid down in this section. Inspect for damage, security and serviceability.

302. Check the wheels and tyres for the following:

- a. Loose wheel nuts.
- b. Correct tyre pressure (see page 75).
- c. Cuts, weak spots, uneven wear, exposed cords, or clogged tyres.

303. Check the following fittings:

- a. All cabin and body fittings.
- b. Spare wheel and canopy.
- c. Stowage space, doors and lids.
- d. Windscreen, driving mirrors, door windows, hinges, catches and latches for security.
- e. Check light lenses, driving mirrors and windscreens and clean.
- f. Tow hook, coupling and security.
- g. Winch rope security.

304. Check the stowed items as follows:

- a. Completeness of equipment and correct stowage.
- b. For loose items in cabin or tray.
- c. De-ditching tools.
- d. Fire extinguisher, fully charged and correctly stowed.

305. Check the fuel, lubricants and coolant as follows:

- a. Fuel level in tank. Replenish as necessary.
- b. Check jerrican and refill if necessary.
- c. Engine oil level using dipstick. Top-up as necessary.
- d. Coolant level in radiator expansion tank. Top-up if necessary.
- e. Water can in stowage. Top-up if necessary.
- f. For fuel, lubricant and coolant leaks. Examine major assemblies and the ground below the vehicle for evidence.

Start the vehicle

306. Start the vehicle as detailed in Chapter 2 Section 2 and check the following:

- | | | |
|----|---------------------------|--|
| a. | Voltmeter | Any irregular readings indicates battery or charging system requires checking. |
| b. | Horn | Check operation of the horn. |
| c. | Lights | Check operation of all lights. |
| d. | Windshield wipers/washers | Check operation. Add water, if needed. |
| e. | Parking brake | Check release, holding ability and application. |
| f. | Clutch pedal | Check for free travel. |
| g. | Seat adjustment | Ensure the seat is correctly adjusted. |

Electrical

307. Check the following:

- | | | |
|----|---|---|
| a. | Battery (for access remove passengers seat cushion) | Check electrolyte level — fill to 10 mm above plates. Check that the terminals are clean and tight. |
| b. | Lights | Switch off all lights not required. |

Moving off and running

308. Check the following:

- Load — Make a final check of the security of load and lashings.
- Moving off — Release the parking brake. DO NOT move off if the parking brake warning light remains illuminated. Check correct operation of steering and brakes.
- Keep a running check on all instruments.
- Check the fuel level, coolant temperature, warning lights, charging rate and speedometer at intervals.

Halts on the march

309. At halts on the march check that:

- The cargo and lashings are secure.
- No tyre is soft, punctured or overheated.
- Wheel hubs or brake drums are not overheated.
- There are no oil, fuel or coolant leaks.

- 310.** At halts or after approximately four hours running:
- a. Check tyre pressures. If low, inflate. (If high, check later when tyres are cold, before deflating.)
 - b. Ensure that all wheel nuts are secure.
 - c. Test all lights (especially if there is a possibility that they will be required).
 - d. Check generally for loose bolts or fittings. Tighten as necessary.
 - e. Ensure security of stowed items.
 - f. Inspect for security and correct operation any parts on which recent repairs or adjustments have been carried out.

Last parade servicing

- 311.** Carry out the following:
- a. Clean the vehicle.
 - b. Carry out "halt on the march" servicing.
 - c. Draw fuel and lubricants, as required and top-up fuel tank, engine oil and radiator expansion tank coolant. If operating under very dusty conditions, the air cleaner should be removed and cleaned.
 - d. If vehicle has been subjected to deep water crossings during daily exercise, the oil in the swivel pin housings, front and rear axles, transmission and transfer case, should be checked for signs of water contamination. If any traces of water are found, the oil should be drained and replenished with correct type as soon as possible.
 - e. Check radiator core for insects, mud etc., clean as required with compressed air or water.
 - f. Complete documentation.
 - g. Close the doors and windows and lace up canopy flaps.

Opening bonnet for servicing access

- 312.** To open the bonnet, proceed as follows:
- a. Pull the bonnet release handle.
 - b. Release the safety catch at the front of the bonnet.
 - c. Lift the bonnet up and pull the support stay forward.

WARNING

Ensure that the bonnet support stay is properly locked before releasing the bonnet.

- 313.** To close the bonnet, proceed as follows:
- a. Hold the bonnet open and push the support stay back.

- b. Gently lower the bonnet then push the bonnet down firmly to lock in position. Do not allow the bonnet to drop from the open position.

Radiator coolant

314. Normal cooling system replenishment is via the expansion tank. However, in the event of excessive coolant loss or drainage, the following radiator filling procedure is to be adopted:

- a. Remove the expansion tank pressure cap and move the heater controls to the highest temperature position.
- b. Remove the brass filler plug from the thermostat housing (see Fig. 3-1).
- c. Using coolant with a mixture concentration of 5% Alfloc 2001, top-up the system through the filler hole, then replace the plug.
- d. With the pressure cap removed, run the engine for a minimum of two minutes.
- e. Stop the engine and remove the plug from the thermostat housing. Top-up as required, then install and tighten the plug securely.
- f. Fill the expansion tank to the correct level and install the cap.
- g. Run the engine and check for leaks.

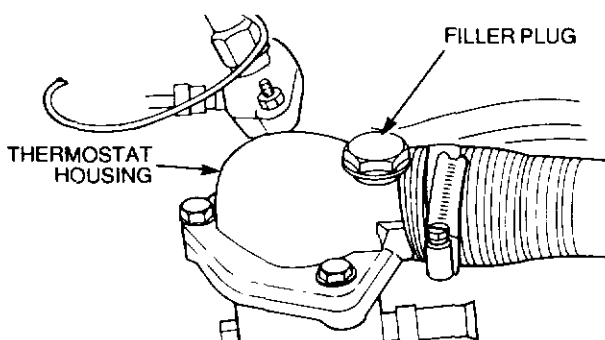

Figure 3-1 Thermostat housing

Bleeding the fuel system

315. To bleed the fuel system, proceed as follows:

- a. Loosen the screw cap on the transfer pump and operate the primer.
- b. Loosen the overflow valve on the fuel filter adapter (see Fig. 3-2) and continue operating the primer until a solid stream of fuel flows from the valve.

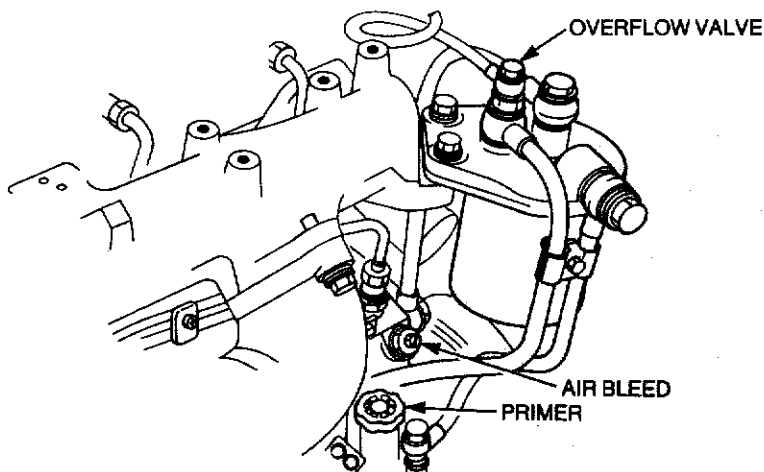

Figure 3-2 Bleeding the fuel system

- c. Tighten the overflow valve and continue operating the primer. Loosen the air bleed screw on the fuel injection pump and continue operating the primer until a solid stream of fuel flows from the air bleed screw. Tighten the air bleed screw.
- d. Secure the primer screw cap and start the engine. Ensure that the engine runs smoothly.

Periodical maintenance

316.

- a. To ensure that the vehicle is correctly maintained and prepared for operational tasks, it is necessary to carry out regular maintenance.
- b. Daily and Fortnightly Servicing in accordance with Tables 3-1 and 3-2 is to be carried out by operators and is the responsibility of owner units.
- c. Initial service should be carried out after the vehicle has been in service for a period of three months, or having travelled 1600 km, whichever occurs first. The service is the responsibility of JRA Limited and will be carried out by arrangement with any Land Rover franchised Dealer at no charge to the Army, except for the cost of replacement lubricants and filters. Alternatively this service can be carried out by an Army tradesman in accordance with Table 3-3, should it not be convenient for the vehicle to be returned to the authorised Land Rover Dealer at that time.
- d. Minor and Major Servicing is to be carried out by RAEME with

assistance from operators working under RAEME supervision in accordance with Tables 3-4 and 3-5. The unit is responsible for ensuring that the vehicle is serviced at the following intervals.

- (1) **Minor Service.** This is to be carried out every six months or 10 000 km of operation, whichever occurs first.
- (2) **Major Service.** This is to be carried out every twelve months or 20 000 km of operation, whichever occurs first.

Special requirements

317. During the early life of a vehicle the working parts settle down, with the result that various clearances and adjustments need to be corrected. Operators should report problems for rectification at the earliest opportunity.

318. The Initial Service includes a warranty inspection which must be reported to Land Rover Australia in accordance with EMEI VEHICLE A 119-22.

Table 3-1 Daily tasks

The following operations are to be performed by the driver:

1. Check engine oil level (top-up if necessary).
2. Check coolant level (top-up if necessary).
3. Check tyres and wheels. Inflate tyres if necessary, inspect wheel nuts for evidence of looseness.
4. Check for fuel, oil and coolant leaks.
5. Check fuel supply and operation of fuel gauge.
6. Check voltmeter reading. With switch on and engine off, indicates battery condition. With engine running, reading indicates condition of charging system.
7. Check operation of horn.
8. Check all lights for correct operation and report any defects.
9. Check operation of foot brake, parking brake and clutch.
10. Check coolant temperature gauge reading.
11. Check operation of windscreen wipers and washers, top-up washer reservoir if required.

12. Check air cleaner restriction gauge reading. If locked in "red" position, the air cleaner elements must be changed. Under dusty conditions, remove and clean elements.
13. Check seats and seat belts for operation and security.
14. Check driving mirrors, door windows, catches and latches.
15. Check winch rope is properly secured.

Table 3-2 Fortnightly tasks

The following operations are to be performed by the driver:

1. Check condition and tension of fanbelts. Approx. 10–15 mm deflection on longest span using moderate thumb pressure.
2. Battery. Check level of electrolyte, top-up if necessary, examine terminals for cleanliness and security. Check for leaks and security, clean outside of battery if required.
3. Check radiator external condition for restriction, clean if required.
4. If operating in dusty conditions, remove air cleaner element and clean.
5. Check operation of hand throttle and stop control.
6. Check operation of differential lock control.
7. Check operation of transfer case control.
8. Check condition of all wheel rims, tyres and valve stems.
9. Check wheel nuts are torqued correctly.
10. Check operation and security of spare wheel carrier.
11. Check security of fuel tank and lines.
12. Check fuel, oil and coolant systems for leaks.
13. Drain water from sedimenter.
14. Check winch rope is properly secured.

Table 3-3 Initial servicing

The following operations are to be performed by the driver under supervision:

1. Start and warm up the engine.

Table 3-3 Initial servicing (cont'd)

2. Stop the engine, drain engine oil and refill.
3. Remove and replace oil filter.
4. Drain and refill transmission.
5. Drain and refill transfer case.
6. Drain and refill front axle.
7. Drain and refill rear axle.
8. Drain and refill swivel pin housings.
9. Lubricate propeller shafts.
10. Lubricate winch propeller shafts and support bearings.
11. Lubricate winch dog-clutch.
12. Lubricate winch rope.
13. Lubricate pintle hook.
14. Lubricate A-frame ball joint mounting.
15. Check oil level in winch gearbox, top-up if necessary.
16. Check battery electrolyte level (10 mm above plates) and security of terminals.
17. Check all fuel and oil lines and unions for leaks.
18. Retorque all wheel nuts to correct specifications.
19. Check tyres and wheels, inflate if necessary. Inspect rims for damage.
20. Check operation of all lights and gauges.
21. Check for loose electrical connections.
22. Check operation of foot brake, parking brake and clutch.
23. Check exhaust systems for leaks, damage and security.

The following operations are to be performed by a Qualified Vehicle Mechanic:

24. Retorque inlet and exhaust manifolds.
25. Check and adjust fanbelt tension. Retorque alternator mounting bolts.
26. Check torque of radiator mounting bolts, tighten as required.

Table 3-3 Initial servicing (cont'd)

27. Tighten all propeller shaft coupling drive bolts.
28. Replace primary fuel filter and bleed system.
29. Road Test. Carry out a road test on steering and brake system. Note all faults and rectify as necessary.

Table 3-4 Minor servicing

The following operations are to be performed by the driver under supervision:

1. Start and warm up engine.
2. Stop engine, drain engine oil and refill.
3. Remove and replace oil filter.
4. Check condition of engine mountings.
5. Check engine hand throttle and stop control for connections and operation.
6. Check all lights and gauges for correct operation, report defects.
7. Check condition of radiator shroud and fins. Clean fins as necessary.
8. Retorque radiator hose connections.
9. Check operation of foot brake, parking brake and clutch.
10. Check operation of windscreen wipers and washers.
11. Check condition of windscreen wiper blades.
12. Check battery electrolyte level (10 mm above plates) and security of terminals. Check battery for cleanliness and security.
13. Check for oil, fuel and coolant leaks. Report any defects.
14. Check tyres and wheels, inflate if necessary. Inspect rims for damage.
15. Drain fuel sedimenter.
16. Drain flywheel housing.
17. Check air cleaner, remove, clean and install. If indicator shows "red" replace elements.
18. Check exhaust system for leaks, damage and security.
19. Check front shock absorbers for leaks, damage and security.

Table 3-4 Minor servicing (cont'd)

20. Inspect front and rear springs for damage.
21. Check oil level in front axle, top-up if necessary.
22. Check oil level in rear axle, top-up if necessary.
23. Check oil level in transmission, top-up if necessary.
24. Check oil level in transfer case, top-up if necessary.
25. Check oil level in swivel pin housings, top-up if necessary.
26. Check oil level in winch gearbox, top-up if necessary.
27. Check brake, fuel and clutch pipes for chafing, leaks or corrosion.
28. Check condition of fanbelt.
29. Check radiator coolant, top-up if necessary.
30. Check brake servo hose for security and condition.
31. Check steering damper for leaks.
32. Check brake fluid reservoir, top-up if necessary.
33. Check clutch fluid reservoir, top-up if necessary.
34. Lubricate pintle hook.
35. Lubricate parking brake mechanical linkage.
36. Lubricate accelerator control linkage and pedal pivot.
37. Lubricate water pump.
38. Lubricate all hinges.
39. Lubricate propeller shafts.
40. Lubricate winch propeller shafts and support bearings.
41. Lubricate winch dog-clutch.
42. Lubricate winch rope.
43. Check operation of spare wheel carrier.
44. Check security of additional equipment.
45. Check driving mirrors, door windows, hinges, catches and latches.

The following operations are to be performed by a Qualified Vehicle Mechanic:

46. Inspect front brake pads for wear, calipers for leaks and the condition of the discs.

Table 3-4 Minor servicing (cont'd)

47. Inspect the rear brake linings and drums for wear.
48. Inspect wheel cylinders for fluid leaks.
49. Adjust rear brakes.
50. Adjust parking brake.
51. Check condition and security of steering unit, joints and boots.
52. Clean fuel pump strainer.
53. Check and adjust fan belt if necessary.
54. Check and adjust engine idle.
55. Check and adjust steering box.
56. Check and adjust head lights.
57. Check front wheel alignment.
- *58. Drain and refill cooling system.

* Coolant to be changed at 10 000 km, then every two years.

Table 3-5 Major servicing

The following operations are to be performed by the driver under supervision:

1. Start and warm up engine.
2. Stop engine, drain engine oil and refill.
3. Remove and replace oil filter.
4. Check condition of engine mountings.
5. Check engine hand throttle and stop control for connections and operation.
6. Check all lights and gauges for correct operation, report defects.
7. Check condition of radiator shroud and fins. Clean fins as necessary.
8. Retorque radiator hose connections.
9. Check operation of foot brake, hand brake and clutch.
10. Check operation of windscreen wipers and washers.
11. Check condition of windscreen wiper blades.

Table 3-5 Major servicing (cont'd)

12. Check battery electrolyte level (10 mm above plates) and security of terminals. Check for cleanliness and security.
13. Check for oil, fuel and coolant leaks. Report any defects.
14. Check tyres and wheels, inflate if necessary. Inspect rims for damage.
15. Drain fuel sediment.
16. Check air cleaners, remove, clean, and install. Fit new elements if indicators show "red".
17. Check exhaust system for leaks, damage and security.
18. Check front shock absorbers for leaks, damage and security.
19. Check front and rear springs for damage.
- *20. Drain and refill front axle.
- *21. Drain and refill rear axle.
- *22. Drain and refill swivel pin housings.
- *23. Drain and refill transmission.
- *24. Drain and refill transfer case.
- *25. Drain and refill winch gearbox.
26. Check brake, fuel and clutch pipes for chafing, leaks or corrosion.
27. Check condition of fanbelt.
28. Check radiator coolant, top-up if necessary.
29. Check brake servo hose for security and condition.
30. Check steering damper for leaks.
31. Check steering box level, top-up if necessary.
32. Check brake fluid reservoir, top-up if necessary.
- *33. Renew brake servo filter.
34. Check clutch fluid reservoir, top-up if necessary.
35. Lubricate pintle hook.
36. Lubricate parking brake mechanical linkage.
37. Lubricate accelerator control linkage and pedal pivot.
38. Lubricate water pump.

Table 3-5 Major servicing (cont'd)

39. Lubricate all hinges.
40. Lubricate propeller shafts.
41. Lubricate winch propeller shafts and support bearings.
42. Lubricate winch dog-clutch.
43. Lubricate winch rope.
44. Check propeller shaft coupling bolts.
45. Check operation of spare wheel carrier.
46. Check security of additional equipment.
47. Check driving mirrors, door windows, hinges, catches and latches.

* Every second major service (40 000 km).

The following operations are to be performed by a Qualified Vehicle Mechanic:

48. Inspect front brake pads for wear, calipers for leaks and the condition of the discs.
49. Inspect the rear brake linings and drums for wear.
50. Inspect wheel cylinders for fluid leaks.
51. Adjust rear brakes.
52. Adjust parking brake.
53. Check condition and security of steering unit, joints and boots.
54. Clean fuel pump strainer.
55. Check and adjust fanbelt, if necessary.
56. Clean and spray test fuel injectors.
57. Clean and test glow plugs.
58. Check engine compression.
59. Clean engine breather filter.
60. Check and adjust engine idle.
61. Check and adjust steering box.
62. Check front wheel alignment.



Tyre pressure (cold)

Highway: front	250 kPa	(36 psi)
rear	350 kPa	(50 psi)

Cross-country: front	200 kPa	(29 psi)
rear	275 kPa	(40 psi)

Sand: front	150 kPa	(22 psi)
rear	225 kPa	(33 psi)

SECTION 2 LUBRICATION

319. Table 3-6 details the lubricants required for vehicle servicing. However, refer to EMEI VEH G 109 for the approved list of lubricants and servicing instructions.

Table 3-6 List of lubricants

Equipment	Lubricant	Capacity (litres)
Engine (including filter)	OMD-115	8.5
Transmission	OMD-115	2.7
Transfer Case	Castrol FMX	3.2
Front Differential	OEP-220	1.7
Rear Differential	OEP-220	2.3
Swivel Pin Housings	OEP-220	0.35 (each)
Brake Master Cylinder	OX (Aust) 8	Fill to level
Clutch Master Cylinder	OX (Aust) 8	Fill to level
Steering Box	OEP-220	0.45
Winch	OEP-220	1.3
Winch Rope	ZX-8	As required
Chassis Lubrication	XG-274	As required
Wheel Bearings	XG-274	As required

320. Fig. 3-3 illustrates the location of various lubrication and oil drainage/refill points around the vehicle.

NOTE

Run the engine or drive the vehicle as appropriate to warm oils before draining.

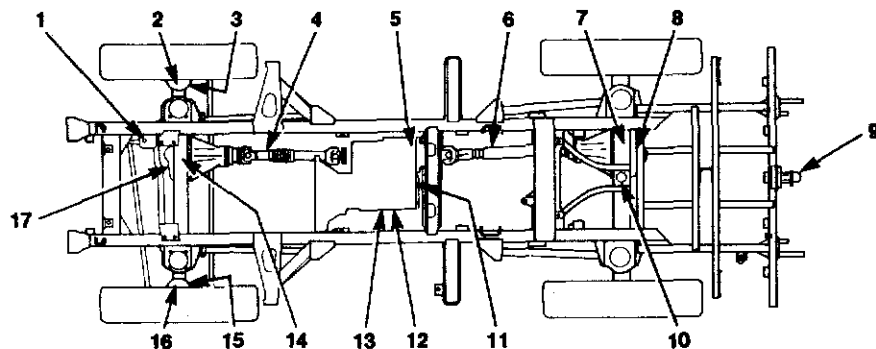

- | | |
|--|---|
| <ol style="list-style-type: none"> 1. Steering box fill plug 2. Right hand swivel pin housing drain plug 3. Right hand swivel pin housing fill plug 4. Front propeller shaft grease nipple 5. Transfer case drain plug 6. Rear propeller shaft grease nipple 7. Rear axle drain plug 8. Rear axle fill plug 9. Pintle | <ol style="list-style-type: none"> 10. Rear suspension A-frame locating arm (upper link) grease nipple 11. Transfer case fill plug 12. Transmission fill plug 13. Transmission drain plug 14. Front axle drain plug 15. Left hand swivel pin housing fill plug 16. Left hand swivel pin housing drain plug 17. Front axle fill plug |
|--|---|

Figure 3-3 Lubrication and oil drain/refill points

321. Fig. 3-4 illustrates the location of lubrication and oil drainage/refill points on the winch and winch drive line.

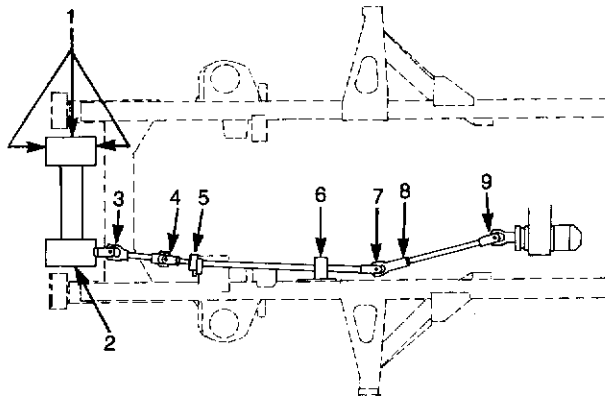

- | | |
|-------------------------------------|---------------------------------------|
| 1. Winch grease points | 6. Pillow block bearing grease nipple |
| 2. Winch drain and fill plugs | 7. Universal joint grease nipple |
| 3. Universal joint grease nipple | 8. Slip joint grease nipple |
| 4. Universal joint grease nipple | 9. Universal joint grease nipple |
| 5. Drop block bearing grease nipple | |

Figure 3-4 Winch and winch drive line

Engine oil and oil filter change procedure

322. Run the engine until the engine coolant reaches normal operating temperature then shut down the engine. Remove the engine oil pan drain plug (see Fig. 3-5) and drain the oil into a suitable receptacle before the engine cools. Remove the drain plug from the oil filter adapter (see Fig. 3-5) and drain the oil into a suitable receptacle. Fit new sealing washers to both drain plugs and install the drain plugs in their respective positions.

323. Unscrew the oil filter cartridge counter-clockwise, using a suitable oil filter removing tool if necessary (see Fig. 3-6). Apply a film of clean engine oil on the rubber seal of the new filter cartridge and install the filter. After the filter seal contacts the adapter, tighten the filter a further half a turn by hand only.

324. Fill the engine with the correct quantity of the recommended lubricant. Do not overfill. Check the level on the dipstick, then run the engine for about five minutes. Stop the engine and check the oil level on the dipstick. Add additional oil as required and check for leaks at the filter.

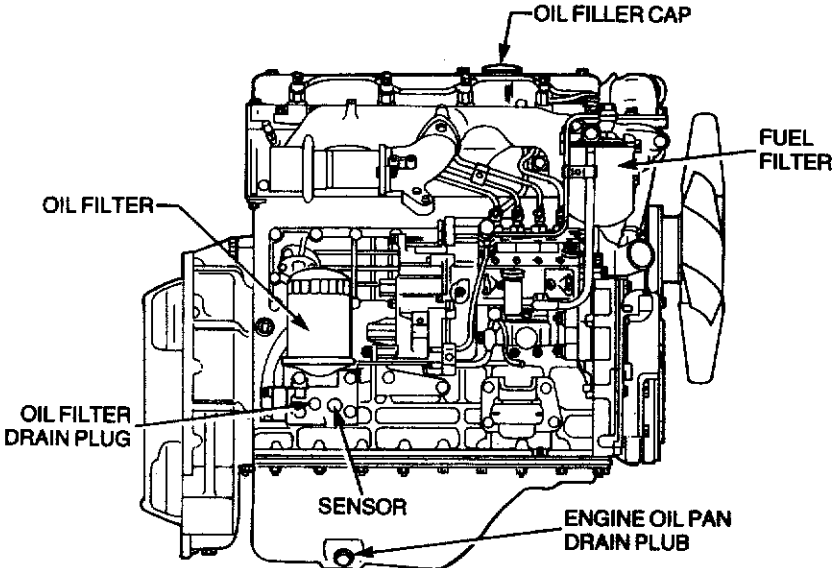

Figure 3-5 Engine — right hand side

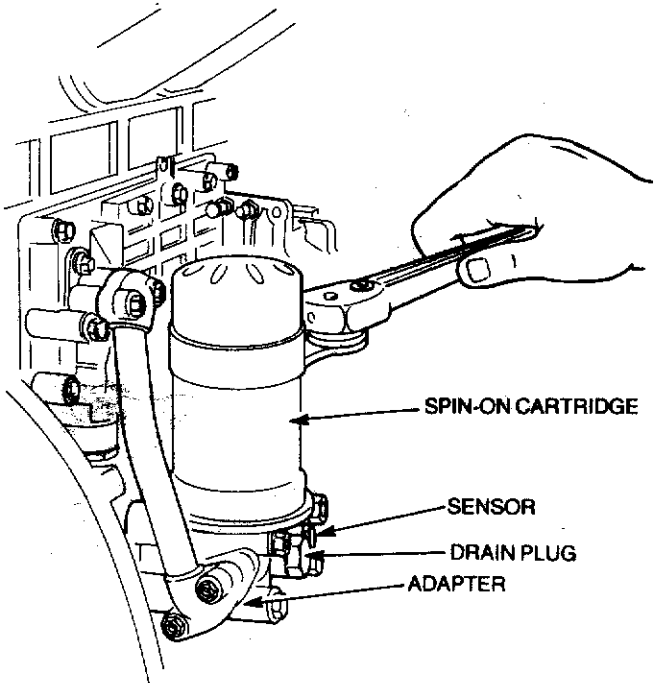

Figure 3-6 Oil filter removal

Transmission

325. The transmission drain plug is located on the left hand side of the transmission. Behind the drain plug is a filter which should be washed in clean fuel each time the transmission oil is drained. Allow the filter to dry completely before installing. Remove and wash the magnetic plug and remove all metallic particles. Install the plug.

326. The transmission fill plug is adjacent to the drain plug (see Fig. 3-7). Fill the transmission with the recommended lubricant to the bottom of the fill hole.

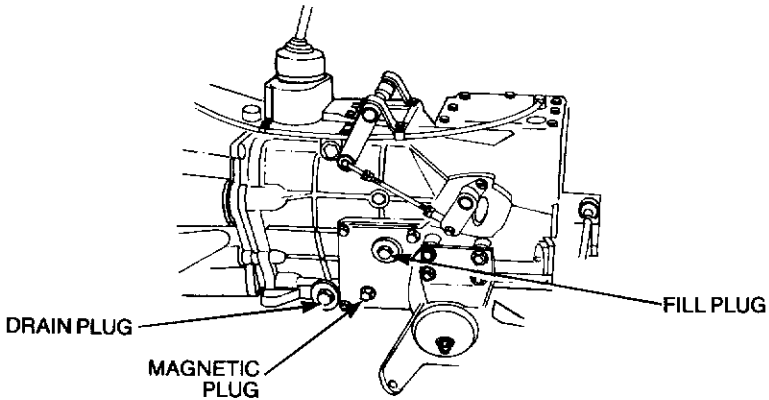

Figure 3-7 Transmission drain and fill plugs

Transfer case

327. The transfer case drain plug is located in the bottom of the PTO housing (see Fig. 3-8). The plug should be cleaned each time the transfer case oil is drained. Use a new sealing washer on installation.

328. The transfer case fill plug is located on the rear of the housing (see Fig. 3-8). Fill the transfer case with the recommended lubricant to the bottom of the fill hole.

329. Ensure that the transfer case breather is not restricted.

Rear axle

330. The drain plug is located on the bottom of the housing, while the fill plug is located on the rear cover (see Fig. 3-9). Fill the differential with the recommended lubricant to the bottom of the fill hole.

331. Ensure that the rear axle breather is not restricted.

Front axle

332. The drain plug is located on the bottom of the housing, while the fill plug is located on the front of the housing. Fill the differential with the recommended lubricant to the bottom of the fill hole.

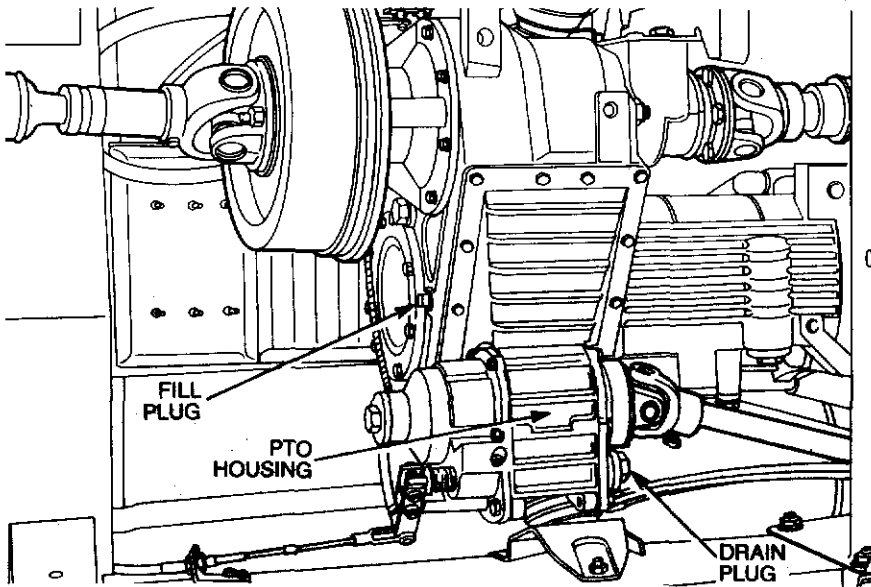

Figure 3-8 Transfer case drain and fill plugs

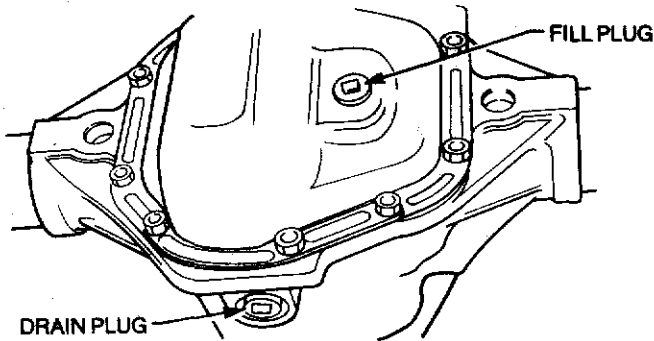

Figure 3-9 Rear axle drain and fill plugs

333. Ensure that the front axle breather is not restricted.

Steering box

334. The oil fill plug is located on the top of the steering box. No drain plug is fitted. Fill the steering box with the recommended lubricant to the bottom of the fill hole.

Swivel pin housings

335. The location of the drain plug and the fill plug is shown in Fig. 3-10.

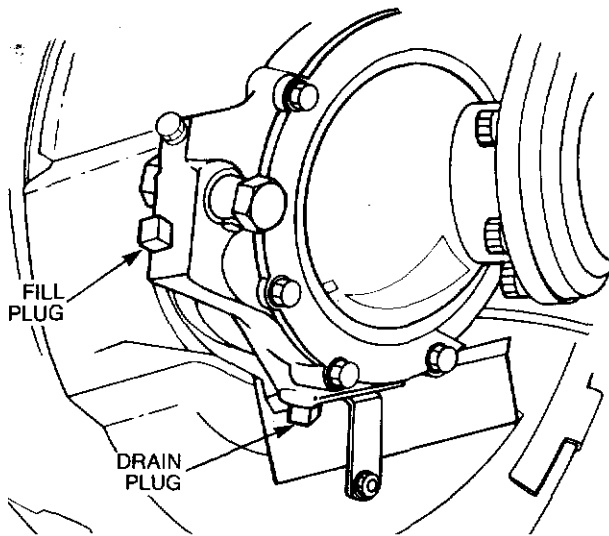

Figure 3-10 Swivel pin housing drain and fill plugs

To drain the swivel pin housing, remove both the fill and drain plugs and drain the oil into a suitable receptacle. Fill the swivel pin housing with the recommended lubricant to the bottom of the fill plug.

Propeller shafts

336. The propeller shafts are each fitted with a grease nipple (see Fig. 3-3 items 4 and 6) and lubrication is required each service.

Rear suspension

337. The rear suspension A-frame locating arm (upper link) is fitted with a grease nipple (see Fig. 3-3 item 10) and lubrication is required each service.

Towing pintle

338. The towing pintle is fitted with one grease nipple and lubrication is required each service.

Water pump housing

339. The water pump is lubricated by a grease nipple located on the top left hand side of the housing and requires lubrication at each service.

Fuel filter

340. Place a suitable container beneath the fuel filter, then, using a

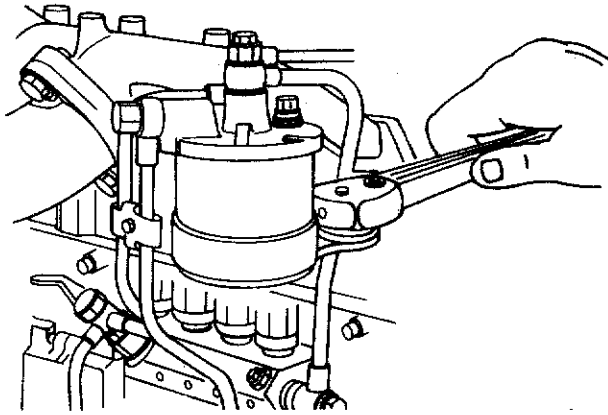

Figure 3-11 Fuel filter

suitable filter-removing tool, remove the filter (see Fig 3-11). Remove the filter rubber seal from the cover. Smear clean fuel on the rubber seal of a new filter and install the new filter on the cover. Tighten the filter by hand until the rubber seal touches the cover face, then tighten a further half a turn. Bleed the fuel system as detailed in Chapter 3 Section 1.

Fuel sedimenter

341. The fuel sedimenter, located on the right hand chassis rail forward of

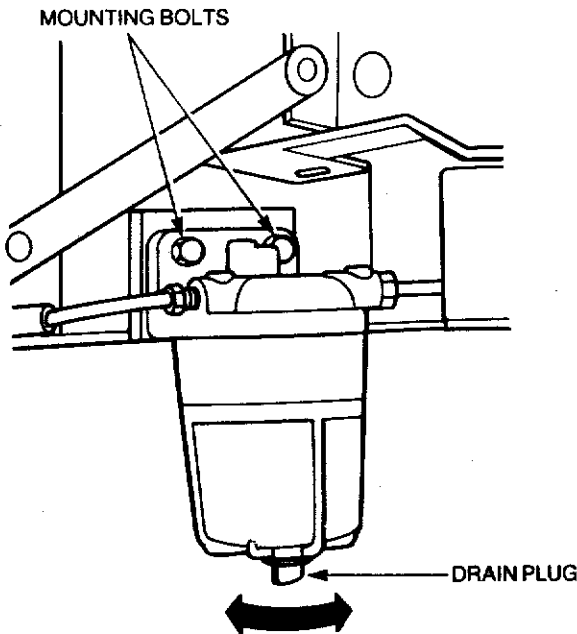

Figure 3-12 Fuel sedimenter

the rear spring mounting. A drain plug is fitted to allow the contents to be drained (see Fig. 3-12). Bleed the fuel system as detailed in Chapter 3 Section 1.

Air cleaner

342. The air cleaner elements will require cleaning or replacement when the signal indicator shows red. To clean or replace the air cleaner elements, proceed as follows:

- a. Remove the hose clamps securing the air inlet and outlet hoses to the air cleaner housing (see Fig. 3-13) then remove the two wing nuts from the clamp bolts. Carefully lift the air cleaner out of the mounting brackets.

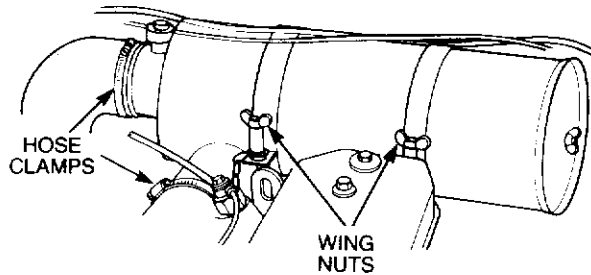

Figure 3-13 Air cleaner removal

- b. Remove the wing nuts securing the end cover and elements.
- c. Wipe out the air cleaner housing with a clean damp cloth. Remove and clean the dust valve (see Fig. 3-14).

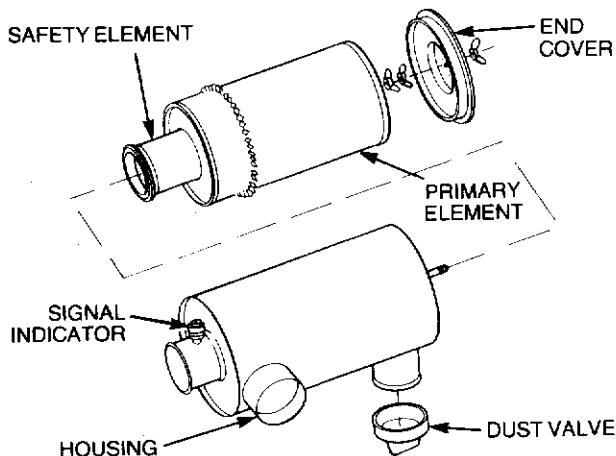

Figure 3-14 Air cleaner elements

- d. Clean or discard the primary element. If the element is to be cleaned, this can be achieved with compressed air or washing with a non-sudsing general purpose detergent (see EMEI VEH A 591-1). If washing, ensure that the element is dry before installing. Do not clean the safety element.
- e. Install and secure the new or cleaned elements, then secure the end cover.
- f. Install the air cleaner assembly and connect the air inlet and outlet hoses. Secure the hose clamps and tighten the wing nuts.
- g. Depress the reset button on the signal indicator to enable the red signal to be released.

Brake reservoir

343. Check the fluid level in the brake reservoir against the level marked on the reservoir. If necessary, remove the reservoir top and top-up with clean brake fluid OX (Aust) 8. See Fig. 3-15 for reservoir location.

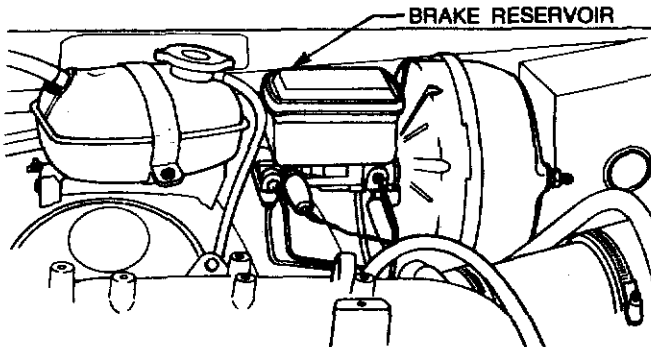

Figure 3-15 Brake reservoir

CLUTCH RESERVOIR

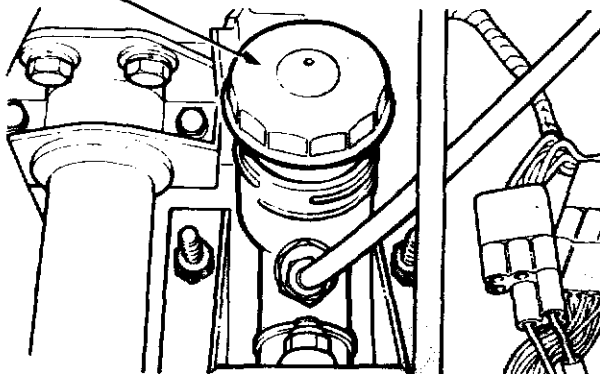

Figure 3-16 Clutch reservoir

Clutch reservoir

344. Remove the reservoir cap and check that the fluid level in the clutch reservoir is up to the bottom of the filler neck. If necessary, top-up with clean brake fluid OX (Aust) 8. See Fig.3-16 for reservoir location.

Winch

345. Remove the winch gearbox fill plug (see Fig. 3-17) and check that the oil level is up to the bottom of the fill plug. Top-up if necessary.

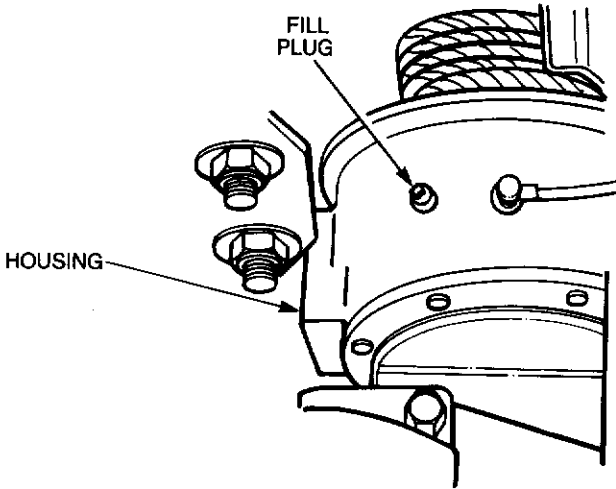

Figure 3-17 Winch fill plug

346. The winch drive line is fitted with seven grease nipples which require lubrication each service.

WARNING

Always wear industrial gloves when handling steel wire rope. Do not use the hands to guide the rope on or off the drum when winching.

347. The winch rope should be pulled out, checked, cleaned and greased at every service. Ensure that a load is maintained on the winch rope when rewinding.

348. To drain the winch gearbox, remove the fill plug, then remove the drain plug which is located on the bottom of the gearbox housing. Drain the oil into a suitable container, then clean and install the drain plug. Top-up the gearbox with clean oil to the bottom of the fill plug hole, then install the fill plug.

349. Ensure that the winch breather is not restricted.

**SIMPLEX COMPLETE EQUIPMENT SCHEDULE 12037
TRUCK, UTILITY, LIGHTWEIGHT, WINCH MC2 — LAND ROVER 110
LIABILITY CODE 72510/10**

ITEMS SUPPLIED/ISSUED WITH TRUCK

**PART 1 — Principal Items
NIL**

PART 2A — Items Essential to Operation of Equipment

Item No.	NATO Stock No.	Designation	Unit of issue	Quantity per sub-assembly	Quantity per ability classification	Foot-note
1	5120-66-048-8548	Baseplate, Jack, Wooden, 12 in. x 12 in. x 2 in.		1	X	
2	6140-66-065-0681	Battery, Storage, 12V, 11 Plate, 80 Amp/hr, 305 mm Lg x 175 mm W x 225 mm H		1	N	
3	8115-66-022-0114	Box, Small Parts, Plastic, 4-1/2 in. Lg x 2-1/2 in. W x 2-3/4 in. H, W/Lid		1	N	
4	7530-66-107-1001	Book, Record, TGM 120, Record Book for Service Equipment		1	X	B
5	NIC	Cover, Fitted, Vehicular Body		1	N	
6	4010-66-021-7290	Chain Assembly, Single Leg, W/Hook, Oblong Link and Removable Joining Links, Chain Size 3/8 in. Gauge by Approx. 5 ft. 3 in. Free Length		1	N	
7	4210-66-089-8751	Extinguisher, Fire, Vaporizing Liquid, Bromochlorodifluoromethane, 1.50 kg Capacity, Stored Pressure, Regulated Discharge Type		1	N	

Item No.	NATO Stock No.	Designation	Unit of issue	Quantity per assembly	Quantity per equipment	Expendability classification	Foot-note
8	NIC	Gauge, Tyre Pressure, Self Contained, Portable, Bar Type			1	X	
9	2610-66-010-7864	Inner Tube, Pneumatic Tyre, Light Truck, 7.50 16, TR 15 Valve			1	N	A
10	5120-66-012-6101	Jack, Hydraulic, Hand, Double Lift, 7-1/2 in. Closed H, 17 in. Extended, 5 Ton W/Handle			1	N	
11	5120-66-014-0251	Pliers, Combination Side Cutting, W/Pipe Grip and Serrated Jaws, Insulated, 6 in. Nom Lg			1	N	
12	4320-00-852-9036	Pump Inflating, Manual, Hand Operated, Single Action, W/30 in. Lg Hose and Adapter			1	X	
13	NIC	Rail, Canopy, Rear			1	N	
14	NIC	Rail, Canopy, Centre			1	N	
15	NIC	Rail, Canopy, Top Front			1	N	
16	5140-66-067-5483	Roll, Tools and Accessories, Cloth Coated Nylon, 2 Pockets, 14 Loops, 690 mm Lg x 380 mm W, W/2 Flaps			1	X	
17	5120-66-024-7832	Screwdriver, Crosstip, Cellulose Acetate Handle, Phillips No. 3 x 150 mm Lg Blade			1	X	
18	5120-66-026-0206	Screwdriver, Flat Tip, Cellulose Acetate Handle, 8 mm W Tip x 150 mm Lg Blade			1	N	
19	NIC	Tyre, Pneumatic, Light Truck, Tubed 7.50 R 16 LT, 10 Ply, Olympic Steel Trek			1	N	A
20	NIC	Wheel Chocks			2	N	
21	NIC	Wheel, Pneumatic Tyre, 6.00 x 16			1	N	A
22	5120-66-013-6747	Wrench, Open End, Adjustable, 250 mm Nom Size			1	X	

Item No.	NATO Stock No.	Designation	Unit of Issue	Quantity per assembly	Quantity per equipment	Expendability classification	Foot-note
23	5120-66-016-1257	Wrench, Open End, Fixed, Double Ended, 15 Degree Offset, 1/2 in. and 9/16 in. A/F		1	1	N	
24	5120-66-016-1255	Wrench, Open End, Fixed, Double Ended, 15 Degree Offset, 5/8 in. and 11/16 in. A/F		1	1	N	
25	5120-66-016-0098	Wrench, Ring, Bi-Hexagon, Double Offset, Double Ended, 1/2 in. and 9/16 in. A/F		1	1	X	
26	5120-66-016-1851	Wrench, Ring, Bi-Hexagon, Double Offset, Double Ended, 5/8 in. and 11/16 in. A/F		1	1	X	
27	NIC	Wrench, Socket, Wheelnut, 4 Way Type 15/16 in. and 1-1/16 in. x 16 in. Nom Lg O/A		1	1	N	
28	NIC	PART 2B — Optional Equipment — To be Demanded Separately Equipment Kit, Vehicular, Truck, Lightweight, MC2, 4 x 4, 4 Cylinder Diesel Engine Manual Transmission, 12V Electrical System Land Rover Model 110 Series (SCES 12036)					

Footnotes

- A. Spare.
- B. Individual pages to be demanded as per User Catalogue for Stationery Supplies (FORMS).

SIMPLEX COMPLETE EQUIPMENT SCHEDULE 12036 EQUIPMENT KIT

ITEMS REQUIRED TO MAKE UP THE EQUIPMENT KIT

PART 1 — Principal Items NIL

PART 2A — Items Essential to Operation of Equipment

Item No.	NATO Stock No.	Designation	Unit of Issue	Quantity per sub-assembly	Quantity per equipment	Expendability classification	Foot-note
1	5110-66-011-0377	Axe, Single Bit, 2 kg, 820 mm Lg			1	X	
2	7240-66-021-5710	Can, Dispensing, Funnel Top, Tin Plate, 1 pint Capacity, W/O Handle			1	X	
3	7240-99-802-2405	Can, Gasoline, Military, Steel, 4-1/2 gallon			1	N	
4	8110-66-016-0717	Can, Screw Cap, Oil, Rect Shape, 5 Litre			1	N	
5	7240-66-054-8602	Can, Water, Military, Plastic, 22 Litre			1	X	
6	2640-00-060-3550	Cap, Pneumatic Valve, Brass, Sealing and Deflating, 5/16 in. Unif Int Thd			5	X	
7	4010-66-086-8463	Chain Assembly, Single Leg, Alloy Steel, 9/32 in. Dia Oblong Link One End, Latch Hook Other End 3.75 m Lg, 3136 lb. Swl	AY		1	N	
8	5120-66-012-6821	Handle, Mattock-Pick, 5 lb. Pick			1	X	
9	5340-66-025-0498	Holder Key, Steel, 3/4 in. ID			2	X	

Item No.	NATO Stock No.	Designation	Unit of Issue	Quantity per assembly	Quantity per equipment	Expendability classification	Foot-note
10	5970-66-018-8475	Insulation Tape, Electrical, Black, 18 mm W x 33 mm Lg		1		X	
11	6240-66-022-3583	Lamp, Incandescent, 12V, 21/6 W, Double Contact Bayonet Candelabra Indexing (Bay 15D)		2		X	
12	6240-66-010-8161	Lamp, Incandescent, 12V, 21 W, Single Contact Bayonet Candelabra Base, 'S' Shape, Clear		2		X	
13	6240-66-013-8678	Lamp, Incandescent, 12V, 6 W, Single Contact Bayonet (BA 9S) Base, 'S' Shape, Clear		2		X	
14	6240-66-010-7460	Lamp, Incandescent, 12V, 5 W, Single Contact Bayonet Candelabra Base, 'G' Shape, Clear		3		X	A
15	6230-99-942-7876	Light, Extension, C/W Cable and Plug, W/O Globe		1		N	
16	5340-66-020-2790	Padlock, Brass, Solid Case, Steel Shackle, 45 mm W, 19 mm Shackle Clearance		2		X	
17	5120-66-012-6893	Pick, Digging, W/O Handle, 5 lb.		1		X	
18	4030-66-123-1450	Shackle, Dee, Alloy Steel, Quality Grade S, 19 mm Nom Size, C/W Metric Thd Collard Eye Pin, 4.7 Tonne Wll, Zinc Coated		2		X	
19	5120-66-093-8563	Shovel, Hand, GS, Rd Point Blade, Plastic D-Handle, Black or Dark Green, 35-1/2 in. Lg O/A		1		X	
20	9905-66-018-3897	Sign, Warning, Portable, Motor Vehicle		3		X	
21	9905-66-048-0206	Tag, Marker, Brass, Rd, 1-1/4 in. Dia		2		X	
22	2640-00-050-1229	Valve Core, Pneumatic Tyre		5		X	
23	7240-66-063-2338	Filler Neck, Pourer, Goose Neck Type, Jerrican		1		X	

PART 2B — Optional Equipment — To be Demanded Separately

NIL

Footnotes

A. Qty. 1 for Light Extension, two spare.

INDEX

A

	Para.
Accelerator pedal	70
Accessories, electrical	52-83
Air cleaner	342
Air distribution control	65
Air temperature control	64
Angles, approach and departure	35
Axle, front	11, 45, 332
Axle, rear	12, 47, 330

B

Blackout lighting	53
Bleeding the fuel system	315
Body and chassis fittings	85-104
Body load area, tray	27
Bonnet, opening	77, 312
Brake, parking	51, 78, 227
Brake pedal	71
Brake system reservoir	343
Brakes, service	49
Brakes, vehicle	17
Braking	225
Bridge classification	31, 104

C

Cabin heating	56
Cabin ventilation	52
Cabin seating	84
Canopy	233
Capacities	29
Carrying capacity, troop	26
Changing a wheel	232
Chassis	18
Chassis and body fittings	85-104
Classification bridge	31, 104
Cleaner, air	342
Clutch	6

Clutch pedal	76
Clutch reservoir	344
C of G designation plate	102
Combination switch	57
Controls, air distribution	65
Cooling system	2
Coolant temperature gauge	62
Cross-country driving	230

D

Data servicing	97
Data summary	1-27
De-ditching tools	90
Dimensions	28
Driving habits	221-231

E

Electric windscreen washers	66
Electrical	307
Electrical, accessories	52-83
Electrical system	20
Electrical system ignition/start switch	72
Electrical trailer connection socket	92
Engine	1, 38
Engine accessory drive	3
Engine oil and oil filter change procedure	322-324
Engine starter	5
Engine, starting	219
Engine, stopping	226
Engine temperature	221
Engine warning lights	61
External lighting	21
Extinguisher, fire	89

F

Fan control	56
Filter, fuel	340
Filter, oil	322-324
Fire extinguisher	89
First parade servicing	301-305
Flywheel housing drain	228-229

Fording depth	30, 228
Front axle	11, 45, 332
Front suspension	14, 46
Fuel filter	340
Fuel gauge	60
Fuel sedimenter	341
Fuel system	4
Fuel system, bleeding	315
Fuse box	81
Fuses	24

G

Gauge, coolant temperature	62
Gauge, fuel	60
Gear changing	224
Gear lever	79
Good driving habits	221-231
Ground clearance	32

H

Habits, driving	221-231
Halts on the march	309-310
Hand throttle	69
Hazard switch	67
Head lights/park lights	57
Heater controls	64-65
High/low beam dipper switch	57
Horn, electric	57
Housing, water pump	339

I

Ignition switch	72
Instruments	52-83
Instrument lights	55
Internal lighting	22, 68
Introduction	36

J

Jacking plate	100
Jerrican stowage	87

K

L

Last parade servicing	311
Lights, warning	61
Lights, instrument	55
Light, map reading	83
Lighting, blackout	53
Lighting, external	21
Lighting, internal	22
Lighting, military	23
Lighting, reduced	53
List of agents	215

M

Maintenance, periodical	316
Map reading light	83
Military lighting	23
Mirrors, rear vision	95
Moving off and running	308
Moving the vehicle	220

N

Nomenclature plate	96
Normal, blackout and reduced lighting	53

O

Odometer	59
Opening bonnet for servicing access	312
Operational and logistic concepts	37
Operation, vehicle	216-240
Oil filter and engine oil change procedure	322-324

P

Panel lights	55
Parking	227
Parking brake	51, 78
Pedal, accelerator	70
Pedal, brake	71

Pedal, clutch	76
Performance	25
Periodical maintenance	316
Pintle, towing	93, 338
POL stowage	87
Plate, C of G designation	102
Plate, jacking procedure	100
Plate, main transmission shift diagram	79
Plate, nomenclature	96
Plate, servicing data	97
Plate, shipping data	98
Plate, towing and dyno test data	99
Plate, winch operation	101
Power take-off	9
Propeller shafts	13, 336

Q

R

Radiator coolant, top-up	314
Rear axle	12, 47, 330
Rear suspension	15, 48, 337
Rear vision mirrors	95
Reduced lighting	53
Reservoir, brake	343
Reservoir, clutch	344
Rifle clips and butt boxes	88

S

Seat belts	94
Seating, cabin	84
Sedimenter, fuel	341
Service brakes	49
Servicing, data plate	97
Servicing, first parade	301
Servicing, last parade	311
Shafts, propeller	13, 336
Shift pattern, main transmission	79
Shift lever, main transmission	79
Shift lever, transfer case	80
Shift pattern, transfer case	80
Shipping data plate	98

Sign, bridge classification	31, 104
Sign, unit/formation	103
Slings and tie-down points	34
Spare wheel stowage and lowering assembly	91
Special requirements	317
Speedometer and odometer	59
Starter, engine	5
Starting engine	219
Steerable front drive axle	45
Steering	16
Steering box	334
Stopping the engine	226
Stowage	86
Stowage, POL	87
Suspension, front	14, 46
Suspension, rear	15, 48, 337
Switch, turn indicator	57
Switch, hazard	67
Switch, head lights/park	57
Switch, high/low dipper	57
Switch, ignition/start	72
Swivel pin housings	335
System, electrical	20

T

Temperature control, heater	64
Temperature coolant gauge	62
Throttle, hand	69
Towing	235
Towing and dyno test data plate	99
Towing pintle	93, 338
Trailer connection socket	92
Transfer case	8, 40, 327
Transfer case control switch	54
Transfer case shift lever	80
Transfer case shift pattern	80
Transmission	7, 39, 325
Transportability	33
Tray body load area	27
Troop carrying capacity	26
Tyres and wheels	19

U

Unit/formation signs	103
----------------------------	-----

V

Vehicle operation	216-240
Vehicle, start	219
Ventilation	52
Voltmeter	63

W

Warning lights	61
Warranty and repair	201-214
Washers, windscreen	66
Water pump housing	339
Wheel changing	232
Wheels and tyres	19
Winch	10, 43, 345
Winch operation	236-242
Winch operation plate	101
Windscreen lowering	234
Windscreen wiper switch	66

NOTES



NOTES



NOTES



NOTES



NOTES



NOTES

