

Landrover V8 Series III

Electronic Ignition Fault Diagnostic Procedure Miscellaneous Instruction

CAUTION

WHERE POSSIBLE BEFORE ANY ELECTRONIC IGNITION TESTING IS DONE, THE CHARGING SYSTEM IS TO BE TESTED FOR PROPER OPERATION AND VOLTAGE OUTPUT. THE VOLTAGE OUTPUT SHOULD BE BETWEEN 27.5 AND 28.5 VOLTS (IF OUTSIDE THIS RANGE ADJUST IT TO 28.2 VOLTS). IF THE CHARGING SYSTEM IS SUSPECTED OF BEING THE CAUSE OF THE ELECTRONIC IGNITION FAILURE, IT IS TO BE RECTIFIED IMMEDIATELY OR IGNITION FAILURE WILL REOCCUR ONCE THE VEHICLE IS STARTED.

Introduction

1. The purpose of this instruction is to inform RNZEME mechanics of safety and diagnostic procedures when testing the V8 electronic ignition system.
2. **Basic Operation.** The V8 electronic ignition uses an opto-electronic switch in the distributor to send on/off pulses to an electronic control unit which turns the ignition coil on/off, allowing a spark to be produced by mutual induction (Lumenition Principle, pg 2).

Detail

3. **Safety Brief.** All electronic ignition systems are dangerous. When working on or near them ensure either the ignition key is turned off or the battery is disconnected. Such work includes:
 - a. replacing components such as sparkplugs, ignition coils, distributors, HT leads and modules;
 - b. connecting test equipment such as timing lights, tunesopes and dwell/tachometers;
 - c. when testing the ignition system with the key on hazardous voltages are present throughout, such tests should only be conducted by RNZEME vehicle mechanics;
 - d. never hold HT leads with pliers when checking for spark, always use a dummy sparkplug.

Note

A dummy sparkplug is a normal plug fitted with an alligator clip, used to reduce high voltages in the high tension circuit to a safer value.

4. This section will be covered as follows:
 - a. No Spark Condition.
 - b. Distributor tests.
 - c. Control assembly internal checks.

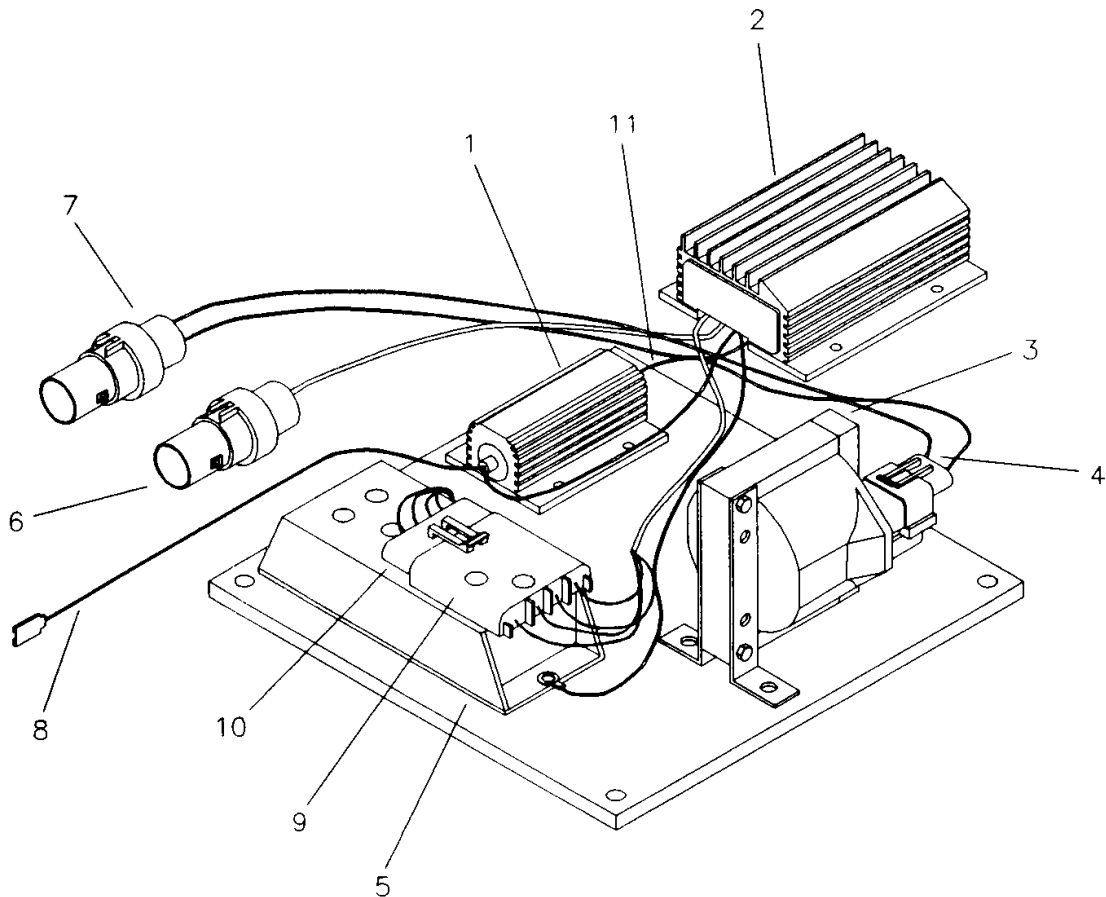

- | | |
|------------------------------------|--|
| 1. Ballast Resistor | 6. Distributor LED Information Socket |
| 2. Control Module | 7. LT Information Socket (Coil Negative) |
| 3. Coil | 8. Ignition Supply 24 V |
| 4. Coil Negative Terminal (Yellow) | 9. Rev-limiter Test Socket Connector |
| 5. Rev-limiter Module | 10. Alternative Rev-limiter Control |
| | 11. Post Ballast Coil Supply |

Figure 1 — R462 Control Assembly

5. **No Spark Condition:**

- a. Conduct a visual inspection of all connections, this includes HT leads, distributor cap, control unit, wiring and opto-electronic switch. (Check also that the rotor turns.)
- b. **Test One.** Check voltage at input wire to Terminal 8 Fig 1 (White Cable). **Result.** 24V should be available with the key on. If not check ignition switch and wiring and repair as required.
- c. Check resistance of the control unit earth connection is less than 1Ω.
- d. Remove the coil HT lead from the distributor cap, fit a dummy sparkplug and check for spark whilst cranking engine. **Result.** **If there is spark,** the fault is in the distributor cap, rotor, HT leads or sparkplugs. **If the spark is weak or absent,** carry out the following tests.

Distributor Tests

6. Conduct Distributor tests as follows:

- a. **Test One.** Check continuity of the coil HT lead (key off) (between distributor cap and ignition coil). **Result.** Should be less than 4 k Ω , replace if required, then test for spark. Normal results will be less than 1 k to a maximum of 4 k Ω .
- b. **Test Two.** Opto-electronic switch test (key off). With the coil Ht lead still connected to the dummy sparkplug, remove the distributor cap/rotor. Turn on the ignition key and place the rotor side on between the opto-electronic switch. By simulating the slots in the rotor (ie, moving the rotor between the opto-electronic switch) a spark should be produced.

Result Distributor Tests:

- (1) **Spark.** Check:
 - (a) distributor cap for tracking and its contacts for corrosion,
 - (b) HT leads using an ohmmeter,
 - (c) sparkplugs, and
 - (d) rotor (by substitution).
 - (2) **No Spark.** Go to Test Three.
- c. **Test Three.** Leave the dummy spark plug in position and **turn off** the key. Bridge the clear and white terminals on the distributor LED info socket (6) and have an assistant turn on the key whilst you observe the dummy spark plug. **Result. Spark.** Replace the electro-optical switch, reconnect the distributor LED info socket and conduct test Two again. If there is still no spark proceed to the control assembly checks.

Control Assembly Internal Checks

7. Remove the R462 control unit **ensuring the earth wire is connected firmly to earth**, and the dummy spark plug is still connected as in test Two, Distributor Tests.
8. Remove the R462 control assembly lid.
9. **Test One.** Battery voltage at (8). Ensure 24V is available at terminal 8 with the key on. **Result.** 24V should be available at R462, if not check earth connection and ignition supply. If battery voltage is available proceed with next test.
10. **Test Two.** Ballast resistor test:
 - a. Turn off the ignition key.
 - b. Disconnect the ignition coil plug (4).
 - c. Check battery voltage is available on both sides of ballast/damper resistor (1) and at terminal 4 (red wire, key on).
 - d. Turn off key. **Result.** If low or no voltage is available, the ballast resistor or wiring is at fault. If battery voltage is available go to test three.
11. **Test Three.** Coil Check:
 - a. Remove the coil plug (4).
 - b. Check continuity across the small input coil terminals. **Result.** 0.4-2.04 Ω , if not replace coil.

- c. Check continuity of HT coil circuit (across HT terminal and a small input terminal). **Result.** 3.2-6 k Ω if the results are significantly higher or lower replace the ignition coil. Proceed with next test.

12. **Test Four.** Speed limiter/spark control module test. Disconnect plug (9), turn on the ignition key and place the rotor side on between the opto-electronic switch. By simulating the slots in the rotor (ie, moving the rotor between the opto-electronic switch) check for spark. **Result.** If **spark is available** the speed limiter (5) is at fault. If there is still **no spark** replace the spark control module (2).