

**TRUCK, CARRYALL, LIGHTWEIGHT, SENIOR COMMANDER, FFR, WINCH, MC2 —
LAND ROVER 110**

MEDIUM AND HEAVY GRADE REPAIR

This instruction is authorised for use by command of the Chief of Army. It provides direction, mandatory controls and procedures for the operation, maintenance and support of equipment. Personnel are to carry out any action required by this instruction in accordance with EMEI General A 001.

TABLE OF CONTENTS

	Page No		Page No
Introduction	3	Fuse Replacement.....	9
Associated Publications	3	Body – Group 17	9
General	4	Windscreen Glass.....	9
Location of Identification Numbers.....	4	Heavy Grade Repair	11
Special Tool	4	Electrical – Group 15.....	11
Medium Grade Repair.....	5	Alternator (28-volt).....	11
Engine – Group 1.....	5	Body – Group 17	11
Crankshaft Oil Seal – Front.....	5	Body.....	11
Electrical – Group 15	7	Tropical Roof	19
Power Distribution Box (PDB).....	7		

LIST OF FIGURES

	Page No		Page No
Figure 1 Special Tool	5	Figure 12 Removal of the Sill.....	12
Figure 2 Removal of the Crankshaft Pulley.....	6	Figure 13 Removal of the Windscreen Frame Bolts	13
Figure 3 Installation of the Crankshaft Front Oil Seal	6	Figure 14 Removal of the Rear Body Bolts	13
Figure 4 24-volt Circuit Diagram	7	Figure 15 Removal of the Windscreen Frame Cover	14
Figure 5 Left Side Battery Compartment.....	8	Figure 16 Removal of the Windscreen Frame Clamp.....	14
Figure 6 Removal of the PDB	8	Figure 17 Rear Body Mountings	15
Figure 7 Rubber Seal - Installing Rope	10	Figure 18 Removal of the Body Brace Support	15
Figure 8 Rubber Seal - Applying Soap Solution.....	10	Figure 19 Removal of the Body Restraining Strap	15
Figure 9 Windscreen Frame - Applying Sealant	10	Figure 20 Removal of the Front Body Mounting	16
Figure 10 Installation of the Windscreen Glass.....	11	Figure 21 Removal of the Body Mounting Bolts	16
Figure 11 Removal of the Rear Mats	12	Figure 22 Removal of the Toe-box Bracket	16

LIST OF TABLES

	Page No		Page No
Table 1 Location of Identification Numbers.....	4	Table 3 List of Lubricants.....	5
Table 2 Special Tool	5	Table 4 Engine Group Specifications	7

UNCONTROLLED IF PRINTED

UNCONTROLLED IF PRINTED

Blank Page

INTRODUCTION

1. This EMEI contains procedures for removing, dismantling, repairing, assembling and installing various components of the Truck, Carryall, Lightweight, Senior Commander, Fitted for Radio, with Winch. Where applicable, instructions for the adjustment, lubrication and minor servicing of these items are included. The EMEI is segregated into both Medium and Heavy Grade Repair at the appropriate paragraphs; common information is listed prior to specific repair criteria. This EMEI supersedes EMEI Vehicle G 144-1 Issue 1.



Do not use adhesive tapes to seal fuel or oil openings. The adhesive tape is soluble in fuel or oil and can cause contamination. Remove temporary covers before assembling.

2. Prevent dirt and foreign objects from entering any component by placing clean temporary coverings over all exposed openings, including hoses, tubes and lines.



Before removing any electrical system components, disconnect the battery leads.

3. When disconnecting electrical connectors, hoses and fittings, remove clamps as required to gain slack and to avoid damage to connectors and fittings.

4. Discard all used gaskets, seals, cotter pins, tab washers, lock pins, key washers and lock washers. Dispose of all contaminated fuel and lubricants drained from the vehicle in accordance with current local instructions.

5. Use only those fuels and lubricants specified in the Servicing Instruction, EMEI Vehicle G 109, the User Handbook and this instruction when replenishing fuel or lubricants.

6. Any fastenings or fittings being tightened to prescribed torques are to have dry, clean threads unless otherwise specified. When specified, thread sealants are to be applied to dry, clean, oil free threads.

7. The engine cooling system contains Nalcool corrosion inhibitor, in water, at a ratio of 1:12.



Precautions should be taken prior to carrying out repairs which include painting, sanding, scraping or welding. Refer to EMEI Workshop D 701 – Repair Policy for Equipment Painted in Polyurethane Paint.

8. This vehicle is painted in polyurethane paint.

Associated Publications

9. Reference may be necessary to the latest issue of the following documents:

- a. Defence Road Traffic Instructions;
- b. Complete Equipment Schedules (CES), Truck, Carryall, Lightweight, Senior Commander, FFR, MC2 – Land Rover 110:
 - (1) SCES 12042; and
 - (2) Equipment Kit SCES 12036;
- c. Block Scale 2406/31 – Special Tools for RAEME – B Vehicles – Truck Utility and Truck Light MC2 (Land Rover Model 110);
- d. EMEI Vehicle A 029 Vehicles General – Servicing of B Vehicles, Trailers, Motorcycles, Stationary Equipment, Auxiliary and Small Engines;

- e. EMEI Vehicle G 008-1 Truck, Lightweight, MC2 – All Types, Inspection of Towing Pintle Assembly;
- f. EMEI Vehicle G 103 Truck, Utility, Lightweight, MC2, Land Rover 110 and Truck, Utility Lightweight, Winch, MC2, Land Rover 110 – Light Grade Repair;
- g. EMEI Vehicle G 104-1 Truck, Utility, Lightweight, MC2, Land Rover 110 and Truck, Utility Lightweight, W/Winch, MC2, Land Rover 110 – Medium Grade Repair;
- h. EMEI Vehicle G 104-2 Truck, Utility, Lightweight, MC2, Land Rover 110 and Truck, Utility Lightweight, W/Winch, MC2, Land Rover 110 – Heavy Grade Repair;
- i. EMEI Vehicle G 109 Truck, Lightweight, MC2, Land Rover 110 4X4 All Types – Servicing Instruction;
- j. EMEI Vehicle G 140 Truck, Carryall, Lightweight, Senior Commander, FFR, Winch, MC2, Land Rover 110 – Data Summary;
- k. EMEI Vehicle G 142 Truck, Carryall, Lightweight, Senior Commander, FFR, Winch, MC2, Land Rover 110 – Technical Description;
- l. EMEI Vehicle G 143 Truck, Carryall, Lightweight, Senior Commander, FFR, Winch, MC2, Land Rover 110 – Light Grade Repair;
- m. EMEI Workshop D 701 Painting of Army Equipment – Repair Policy for Equipment Painted in Polyurethane Paint;
- n. Repair Parts Scale 02194;
- o. [Material Safety Data Sheets](#) (MSDS); and
- p. [SAFETYMAN](#) – Defence Safety Manual.

WARNING

All industrial safety, work practices and equipment operating and maintenance instructions pertaining to this EMEI are to be adhered to.

The handling, storage and use of chemical substances is to be in accordance with SAFETYMAN, MSDS and EMEI Workshop series requirements.

GENERAL

Location of Identification Numbers

10. The location of identification numbers on components of the vehicle are described in Table 1.

Table 1 Location of Identification Numbers

Serial	Identification Number	Location
1	Chassis	Right-hand side of the chassis, forward of the spring mounting turret
2	Chassis nameplate	Left-hand seat box, in the cab
3	Engine	Left-hand side of the engine block
4	Injection pump identification	Side of the pump
5	Transmission and transfer case	Rear of the transfer case
6	Torque limiter	On the rear end of the drive plate
7	Front axle	Adjacent to the axle breather
8	Rear axle	Adjacent to the axle breather

Special Tool

11. The special tool required for maintenance is detailed in Table 2.

NOTE

NSN and Manufacturers part numbers and designations used in this EMEI were current at the date of issue. If twelve months or more have expired since issue, the NSN and Manufacturers part number should be checked for supersession.

Table 2 Special Tool

Part No.	NSN	Item Name	Use
18GA092	5120-66-128-4312	Inserter, Seal	Installing crankshaft front oil seal

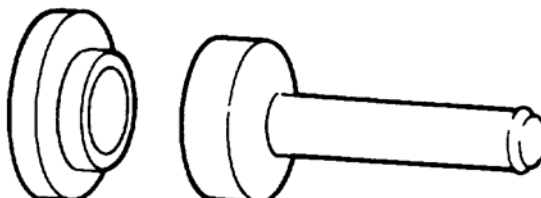

18GA092

Figure 1 Special Tool

12. The list of lubricants is detailed in Table 3.

Table 3 List of Lubricants

Serial	Equipment	Lubricant	Capacity (litres)
1	Engine (including filter)	OMD-115	8.5
2	Transmission	OMD-115	2.7
3	Transfer case (without PTO)	OMD-115	3.2
4	Transfer case (with PTO)	OMD-115	5.8
5	Front differential	OEP-220	1.7
6	Rear differential	OEP-220	2.3
7	Swivel pin housings	Molytex Grease	EP00 Sachet
8	Brake master cylinder	OX (Aust) 8	Fill to level
9	Clutch master cylinder	OX (Aust) 8	Fill to level
10	Steering box	OEP-220	0.45
11	Fanbelt jockey pulley	XG-291	As required
12	Wheel bearings	XG-291	As required
13	Winch rope	Rocol wire rope lube NSN 9150-99-337-1498	As required
14	Radiator inhibitor	Nalcool	As required (1:12 ratio)
15	Propeller shaft	XG-291	As required
16	Winch drive line	XG-291	As required
17	Winch	OEP-220	1.3

MEDIUM GRADE REPAIR

ENGINE – GROUP 1

Crankshaft Oil Seal – Front

13. **Removal.** Remove the crankshaft front oil seal as follows:
- a. Remove the radiator in accordance with EMEI Vehicle G 103 – Group 2.
 - b. Clean the crankshaft pulley and surrounding area with a recommended cleaning agent and blow it dry with compressed air.

UNCONTROLLED IF PRINTED

- c. Slacken the adjusting bolt on the pulley arm and detach the two fanbelts from the crankshaft pulley and 28-volt alternator.
- d. Loosen the 12-volt alternator adjusting and mounting bolts and move the alternator towards the engine. Remove the fanbelt.
- e. Ensure that the parking brake is applied, low gear is selected and all the wheels are chocked. Remove the crankshaft front nut and washer (Figure 2) and remove the pulley.

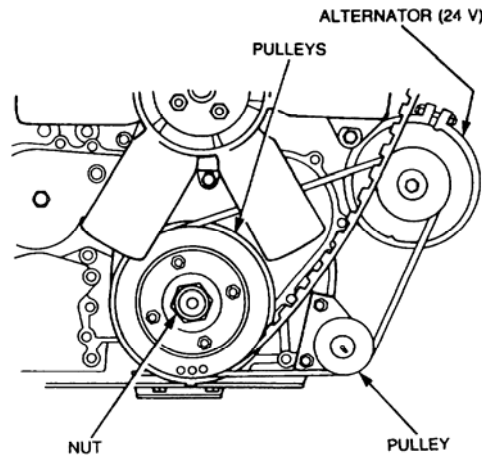

Figure 2 Removal of the Crankshaft Pulley

- f. Remove the oil seal using a lever or seal puller as required.

14. Installation. Install the crankshaft front oil seal as follows:

- a. Lubricate the outer surface of a new seal with clean engine oil, then position the seal on the timing case cover. Install the seal using special tool 18GA092 (Figure 3).

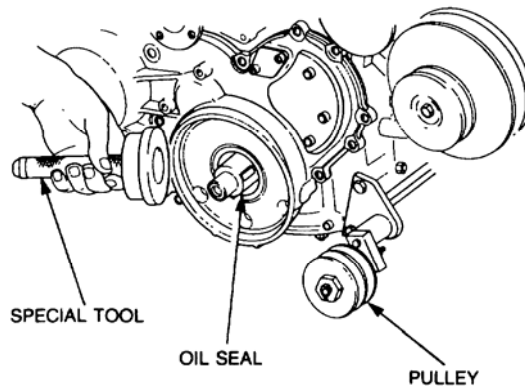

Figure 3 Installation of the Crankshaft Front Oil Seal

- b. Ensure that the seal rubbing surface on the pulley is not grooved or worn.
- c. Install the pulley, washer and nut and torque the nut to 382 to 480 N.m (282 to 354 lbf.ft).
- d. Install the fanbelt then adjust the 12-volt alternator for a 10 to 15 mm deflection on the longest span of the fanbelt, when depressed with the thumb.
- e. Fit the two 28-volt alternator fanbelts in the pulley grooves then position the pulley arm to allow a deflection of 5 to 10 mm on the longest span of the belts, and tighten the locknut securely.
- f. Install the radiator in accordance with EMEI Vehicle G 103 – Group 2.

UNCONTROLLED IF PRINTED

Table 4 Engine Group Specifications

Serial	Item	Specification
1	12-volt alternator - fanbelt deflection	10 to 15 mm
2	28-volt alternator - fanbelt deflection	5 to 10 mm
3	Crankshaft front nut tightening torque	382 to 480 N.m (282 to 354 lbf.ft)

ELECTRICAL – GROUP 15

Power Distribution Box (PDB)

15. Test the PDB as follows:

- a. Switch the master switch on the PDB to the ON position and check the reading on the battery condition indicator. The voltage reading should be approximately 24 volts.
- b. Start the engine and set the hand throttle for approximately 1500 rpm.
- c. Check that the dash mounted ammeter indicates that the batteries are being charged, and that the battery condition indicator now reads approximately 28 volts.
- d. Reduce engine speed to idle and switch off the ignition.
- e. Switch the master switch on the PDB to the OFF position.

NOTE

If the battery condition indicator continues to indicate when the master switch is in the OFF position, modify the PDB in accordance with EMEI Vehicle G 187 – 14.

f. The circuit diagram is shown in Figure 4.

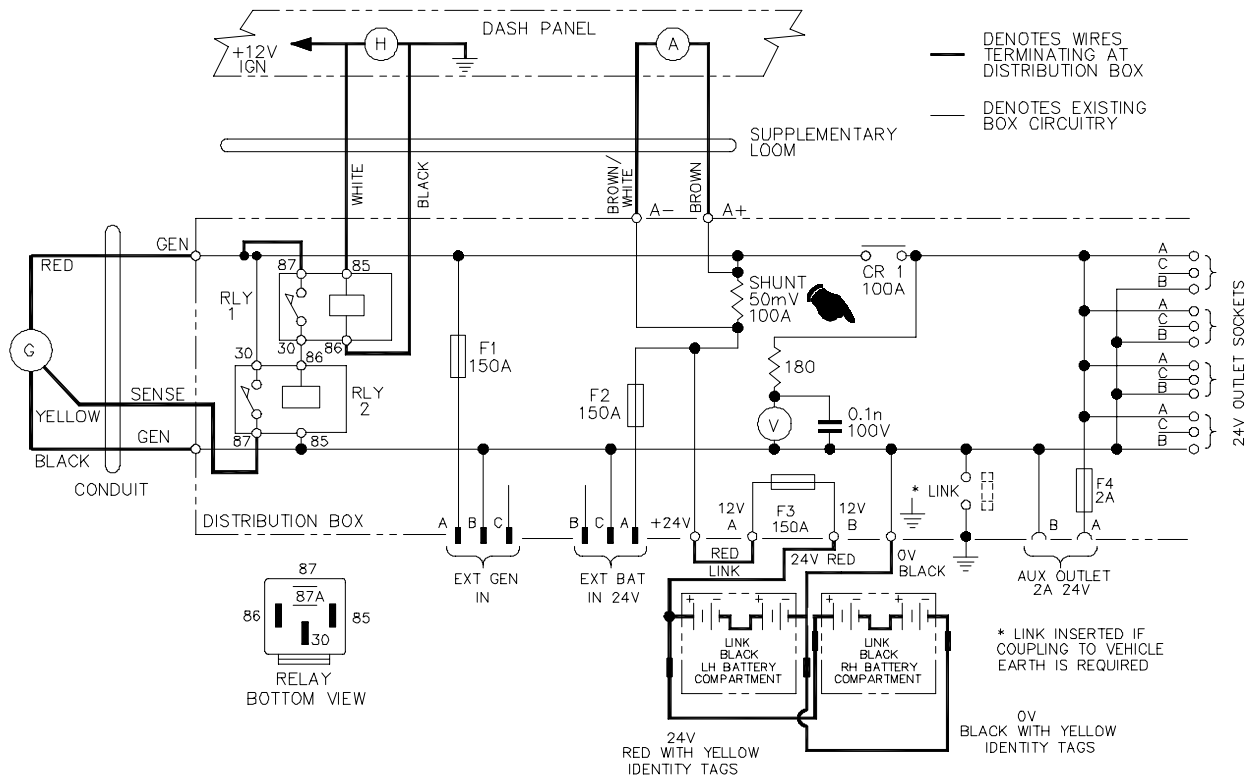

DE(EMEI) 3422-4

Figure 4 24-volt Circuit Diagram

UNCONTROLLED IF PRINTED

16. **Removal.** Remove the PDB as follows:
- Ensure the master switch on the PDB is in the OFF position.
 - Disconnect any plugs connected to the PDB outlets/inlets.
 - Remove the security clip and pin from the left hand battery carrier (Figure 5) and slide the batteries and carrier clear of the vehicle body until the small bridging cable is exposed.

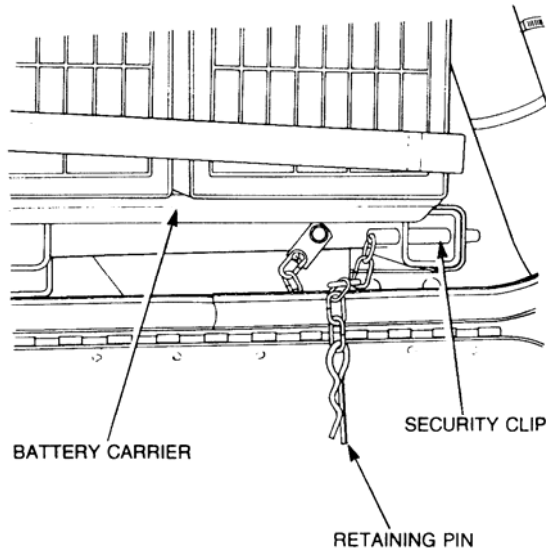

Figure 5 Left Side Battery Compartment



When removing the bridging cable, extreme care must be taken to prevent the cable ends shorting out on the vehicle body.

- Disconnect the bridging cable from both the positive and negative terminals on the batteries. Remove the cable.
- Repeat the procedure for the batteries installed on the right side of the vehicle.
- Disconnect the main vehicle battery located under the front passenger seat.
- Remove the six screws securing the front panel and hinged top section of the PDB (Figure 6). Withdraw the front panel from the PDB to allow the power terminals to be exposed. Tag and disconnect all cables, then remove all cables from the bottom of the PDB.

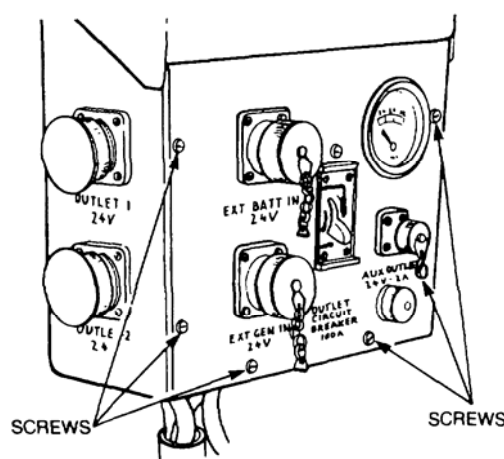

Figure 6 Removal of the PDB

- h.** Remove the four hexagonal headed screws securing the PDB to the vehicle body. Remove the PDB.

- 17. Installation.** Install the PDB as follows:

NOTE

Ensure the cables connecting the generator input connector to the battery connections inside the PDB have been modified in accordance with EMEI Vehicle G 187 – 15.

- a.** Position the PDB on the vehicle body and secure it with the four hexagonal headed screws.
- b.** Feed all the power cables through the bottom of the PDB ensuring that all grommets are fitted correctly.
- c.** Connect all the power cables to the correct terminals, as tagged on removal.
- d.** Fit the front and hinged sections on the PDB and secure with them the six screws.
- e.** Connect the bridging cable between the positive and negative battery terminals fitted to the right side of the vehicle.
- f.** Stow the batteries and carrier and secure the carrier with the pin and security clip.
- g.** Repeat the procedure for the batteries installed on the left side of the vehicle.
- h.** Connect the battery installed under the front passenger seat.

Fuse Replacement

- 18.** Replace the fuses as follows:

- a.** Ensure the master switch on the PDB is in the OFF position.
- b.** Disconnect any plugs connected to the PDB outlets/inlets.
- c.** Remove the two screws securing the PDB lid and open the lid.
- d.** Check the fuses using a continuity tester.
- e.** Remove faulty fuses by loosening the nuts securing the fuse terminals to the posts and remove the fuse.

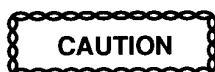

Replace fuses with fuses of the same size and type. Determine the cause of failure of the fuse and rectify as necessary.

- f.** Fit the new fuse to the terminal posts and tighten the nuts securely.
- g.** Close the power distribution box lid and secure it with the two screws.

BODY – GROUP 17

Windscreen Glass

- 19. Replacement.** Replace the windscreen glass using the following procedure:

NOTE

It will be necessary to utilise a second person to assist in the replacement of the windscreen glass.

- a.** Apply even pressure to the inside face of the glass and push the glass and rubber surround out of the frame.
- b.** Remove all trace of hardened sealer from the frame.
- c.** Install the windscreen rubber on the new glass.

NOTE

The inside face of the glass can be determined by the etched motif.

- d. Using approximately four metres of rope with a diameter of seven millimetres, insert the rope into the groove of the rubber seal (Figure 7) starting at the bottom centre of the glass and leaving enough rope at the start to enable the rope to be pulled on installation.

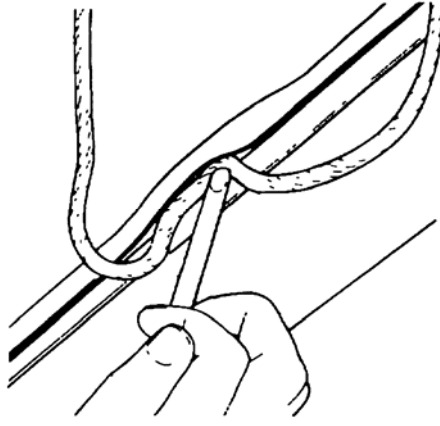

Figure 7 Rubber Seal - Installing Rope

- e. Using a solution of soap and water, lubricate the rope and the rubber thoroughly (Figure 8).

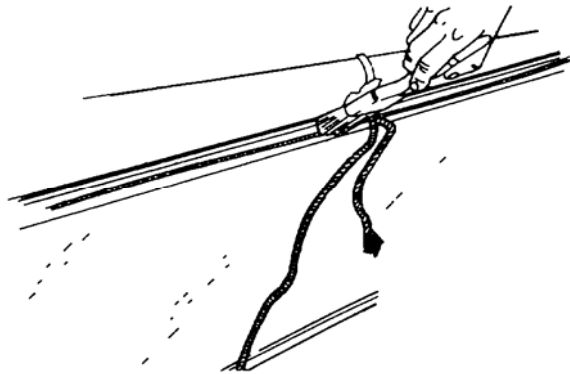

Figure 8 Rubber Seal - Applying Soap Solution

- f. Apply a thin bead of suitable sealant to the front face of the windscreen frame flange (Figure 9).

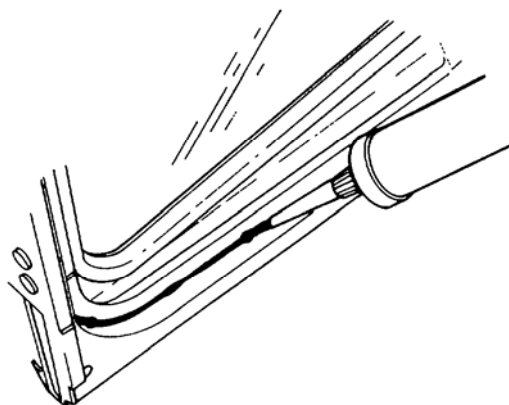

Figure 9 Windscreen Frame - Applying Sealant

- g. Position the windscreen glass and rubber in the frame (Figure 10), ensuring that the etched motif on the glass is towards the bottom of the frame.

UNCONTROLLED IF PRINTED

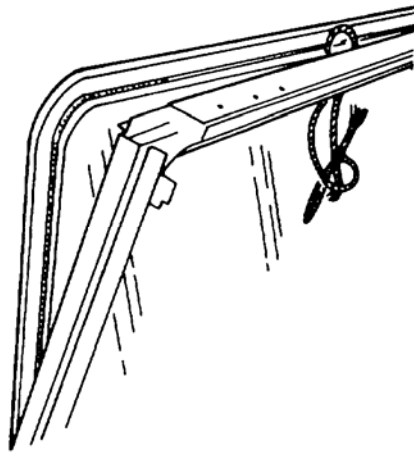

Figure 10 Installation of the Windscreen Glass

- h.** Push on the glass continuously and pull one end of the rope around the rubber until the frame flange is correctly located. If the corners are not fitting correctly, remove the glass, install the rope and repeat the actions described in sub paragraphs g. and h. until the glass is installed.
- i.** Press the inside face of the rubber seal to ensure that the glass is seating correctly.

HEAVY GRADE REPAIR

ELECTRICAL – GROUP 15

Alternator (28-volt)

- 20. Overhaul Procedure.** Overhaul the 28-volt alternator in accordance with EMEI Electrical P 414 - 2.

BODY – GROUP 17

Body

- 21. Removal.** Remove the body as follows:
 - a.** Remove the batteries (24-volt installation) and cables in accordance with EMEI Vehicle G 143 – Group 15. Remove and discard any cable ties securing the electrical harnesses to the chassis crossmember.
 - b.** Remove the vehicle battery (12-volt installation) and cables in accordance with EMEI Vehicle G 103 – Group 15.
 - c.** Remove the brushguard in accordance with EMEI Vehicle G 103 – Group 16.
 - d.** Remove the winch and fairlead in accordance with EMEI Vehicle G 104-1 – Group 19.
 - e.** Remove the bonnet in accordance with EMEI Vehicle G 104-1 – Group 17.
 - f.** Remove both windscreen wiper arms and blades.
 - g.** Disconnect the Cannon plug on the 28-volt alternator output and remove the clips securing the electrical harness to the left side inner wheel arch inner panel in accordance with EMEI Vehicle G 143 – Group 15.
 - h.** Remove the grille in accordance with EMEI Vehicle G 103 – Group 17.
 - i.** Remove the radiator in accordance with EMEI Vehicle G 103 – Group 2.
 - j.** Remove the mudguards in accordance with EMEI Vehicle G 104-1 – Group 17.
 - k.** Remove the front doors in accordance with EMEI Vehicle G 143 – Group 17.
 - l.** Remove the rear doors in accordance with EMEI Vehicle G 143 – Group 17.
 - m.** Carefully remove the front and rear door seal rubbers from the door frames.

- n. Remove the screw securing the rear mat retaining plates to the floor (Figure 11) and remove the plates and mats.

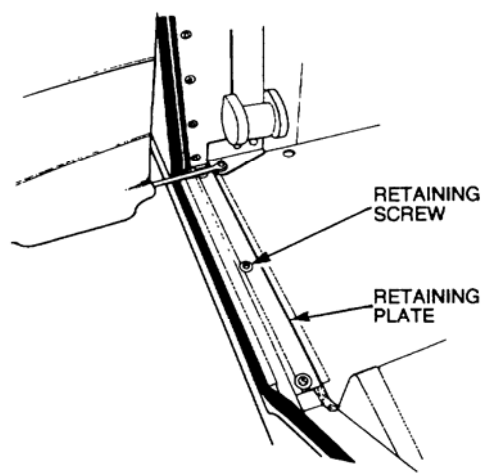

Figure 11 Removal of the Rear Mats

- o. Remove the eleven screws securing the rear floor panel to the body and remove the panel.
- p. Remove the front floor panels in accordance with EMEI Vehicle G 103 – Group 17.
- q. Loosen the screws securing the cargo area mat retaining plate and slide the mat from under the plate and out of the vehicle.
- r. Remove the bolts, nuts and washers securing the sill panel to the body and stay (Figure 12).
- s. Repeat the procedure for the opposite side.
- t. Remove the plastic clips securing the wheel arch extensions to the sills and remove the sills.

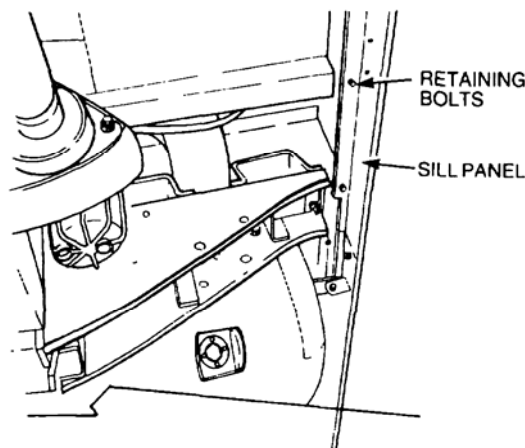

Figure 12 Removal of the Sill

- u. Remove the rear and inward facing seats in accordance with EMEI Vehicle G 143 – Group 17.
- v. Remove the eight bolts securing the roof panel to the top of the windscreen frame (Figure 13) and discard the sealing strip.

UNCONTROLLED IF PRINTED

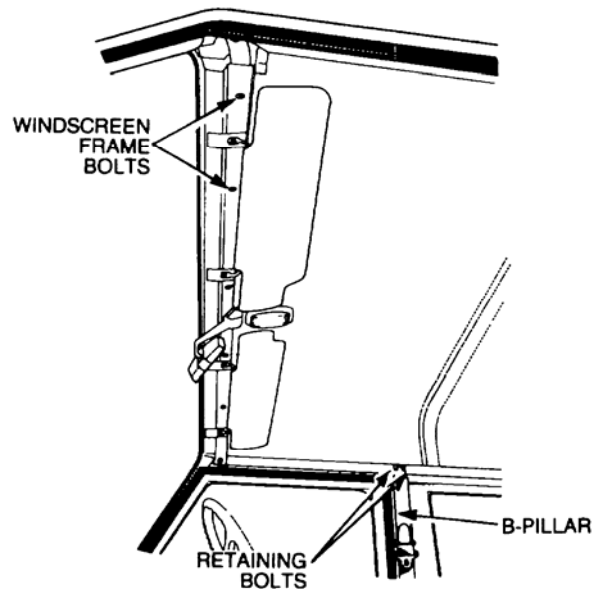

Figure 13 Removal of the Windscreen Frame Bolts

- w. Remove the four nuts and bolts that secure the roof panel to the top of pillars B (Figure 13) and C (opposite side of vehicle).
- x. Remove the ten nuts and bolts that secure the upper body panels to the lower body frame (Figure 14).
- y. Using suitable overhead lifting equipment, with a minimum safe working load of 500 kg, remove the upper body panels from the vehicle and lower the upper body panels onto suitable axle stands.

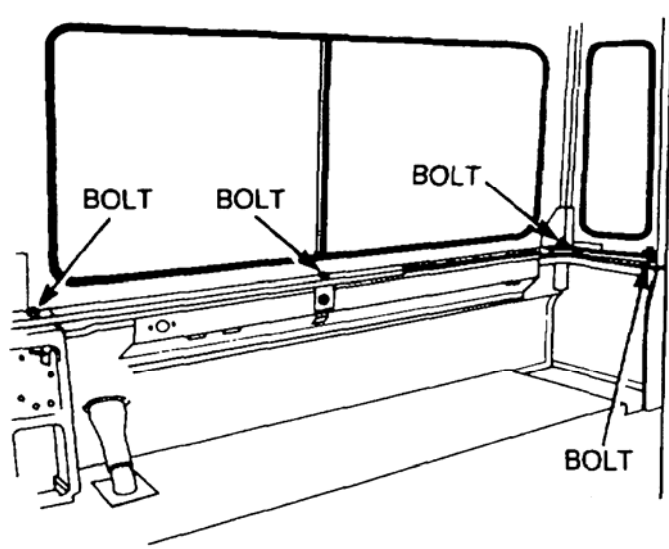

Figure 14 Removal of the Rear Body Bolts

- z. Remove the interior light lens and disconnect the wiring harness from the light unit.
- aa. Remove the harness from the windscreen frame in accordance with EMEI Vehicle G 104-2 – Group 15.
- bb. Remove the three screws from each of the vertical cover strips on the inside of the windscreen frame (Figure 15) and remove the cover strip from the vehicle.

UNCONTROLLED IF PRINTED

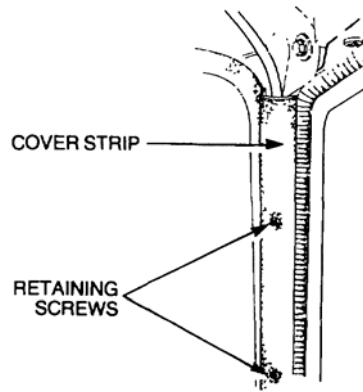

Figure 15 Removal of the Windscreen Frame Cover

- cc.** Remove the hinge bracket retaining bolts from both sides of the windscreen frame and lift the windscreen assembly away from the vehicle.
- dd.** Remove the locknuts and washers from the clamps securing the windscreen frame to the firewall (Figure 16).

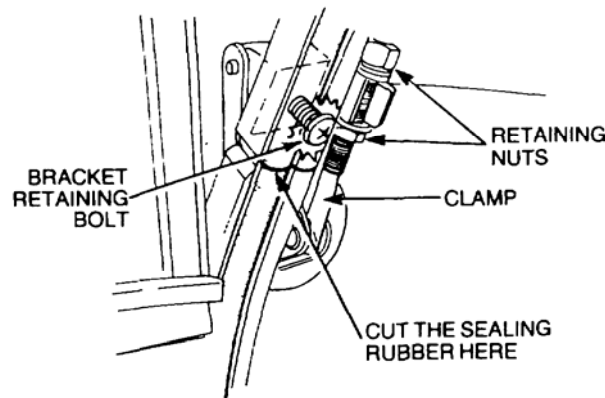

Figure 16 Removal of the Windscreen Frame Clamp

- ee.** Remove the exhaust system in accordance with EMEI Vehicle G 103 – Group 3.
- ff.** Disconnect the axle and gearbox breather hoses in accordance with EMEI Vehicle G103 – Group 6.
- gg.** Remove the speedometer cable in accordance with EMEI Vehicle G 103 – Group 6.
- hh.** Tag and disconnect the main wiring harness at the firewall in accordance with EMEI Vehicle G 143 – Group 15 and remove all clips and cable ties that secure the harness to the firewall.
- ii.** Disconnect the steering column at the firewall in accordance with EMEI Vehicle G104-1 – Group 14.
- jj.** Disconnect the fuel tank breather and filler neck hoses in accordance with EMEI Vehicle G 143 – Group 4.
- kk.** Remove the front seats in accordance with EMEI Vehicle G 103 – Group 17.
- ll.** Remove the parking brake cable in accordance with EMEI Vehicle G 103 – Group 12.
- mm.** Remove the bolts securing the jerrican holders to the chassis and body.
- nn.** Remove the ten bolts securing the body to the rear crossmember (Figure 17).

UNCONTROLLED IF PRINTED

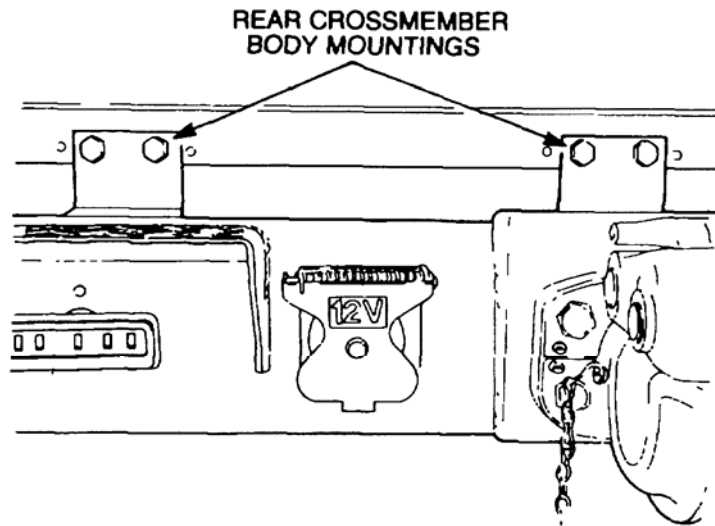

Figure 17 Rear Body Mountings

- oo. Remove the bolts, nuts and washers securing the rear body crossmember to the chassis frame (Figure 18).

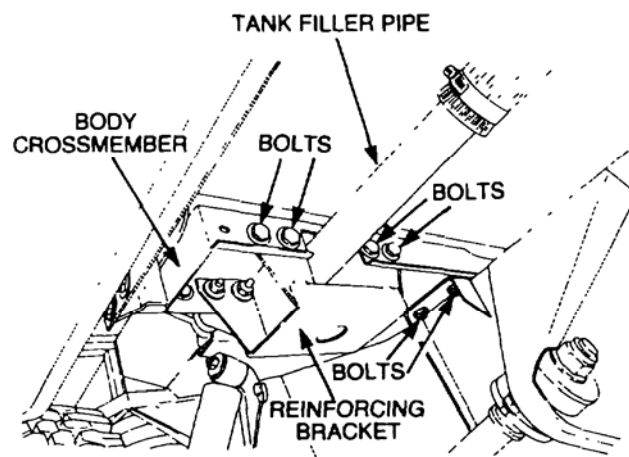

Figure 18 Removal of the Body Brace Support

- pp. Remove the bolts securing the rear body restraining straps (Figure 19) to the chassis.

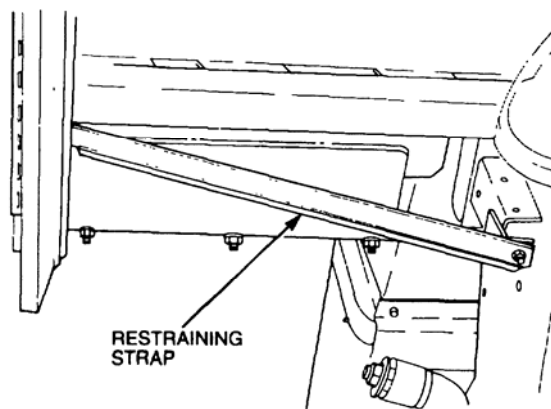

Figure 19 Removal of the Body Restraining Strap

- qq. Remove the bolts securing the front body mountings to the chassis brackets (Figure 20).

UNCONTROLLED IF PRINTED

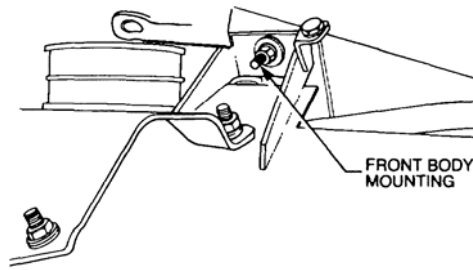

Figure 20 Removal of the Front Body Mounting

- rr. Remove the nuts, washers and bolts from the reinforcing bracket fitted to the detachable body crossmember (Figure 18) and remove the bracket from the crossmember.
- ss. Remove the eight bolts, nuts and washers securing the body mounting brackets to the chassis frame outrigger (Figure 21).
- tt. Repeat the procedure for the opposite side.
- uu. Remove the battery earth cable from the left side outrigger.

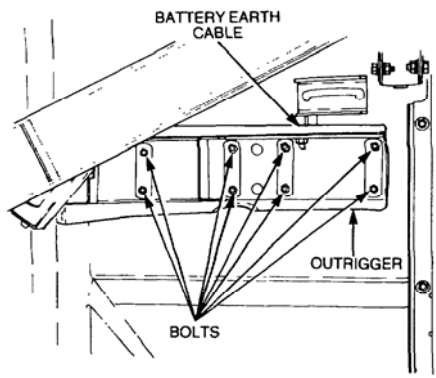

Figure 21 Removal of the Body Mounting Bolts

- vv. Check that all the mounting bolts and cables have been removed or disconnected.
- ww. Using suitable overhead lifting equipment, with a minimum safe working load of 500 kg, carefully raise the body assembly off the chassis frame and lower the body onto suitable axle stands.
- xx. Remove the bolts securing the firewall toe-box brackets to the chassis (Figure 22)
- yy. Using suitable overhead lifting equipment, with a minimum safe working load of 500 kg, attach two slings to the windscreen mounting holes.
- zz. Remove the bolts securing the firewall to the outriggers and raise the firewall off the chassis frame.

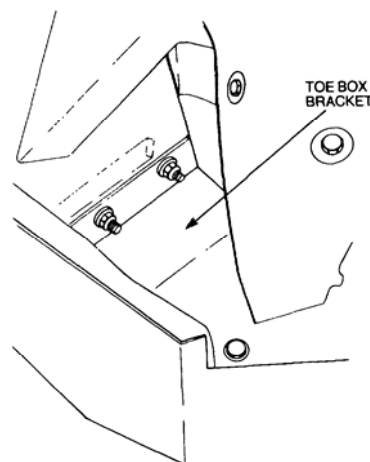

Figure 22 Removal of the Toe-box Bracket

UNCONTROLLED IF PRINTED

- aaa.** Remove the heater assembly in accordance with EMEI Vehicle G 103 – Group 18.
- bbb.** Remove the clutch master cylinder and pedal bracket in accordance with EMEI Vehicle G 103 – Group 5.
- ccc.** Remove the brake servo cylinder and pedal bracket in accordance with EMEI Vehicle G 103 – Group 12.
- ddd.** Remove the dashboard in accordance with EMEI Vehicle G 104-2 – Group 17.
- eee.** Remove the steering column in accordance with EMEI Vehicle G 104-1 – Group 14.
- fff.** Remove the fuel tank in accordance with EMEI Vehicle G 143 – Group 4.

NOTE

The engine and transmission can be removed as an assembly if required.

- ggg.** Remove the engine in accordance with EMEI Vehicle G 104-1 – Group 1.
 - hhh.** Remove the transmission in accordance with EMEI Vehicle G 104-1 – Group 6.
 - iii.** Remove the wiring harnesses in accordance with EMEI Vehicle G 143 – Group 15.
- 22. Inspection.** Inspect the body for corrosion, dents, cracks and loose rivets. Repair or replace as necessary.
- 23. Installation.** Install the body as follows:
- a.** Install the wiring harnesses in accordance with EMEI Vehicle G 143 – Group 15.
 - b.** Install the transmission in accordance with EMEI Vehicle G 104-1 – Group 6.
 - c.** Install the engine in accordance with EMEI Vehicle G 104-1 – Group 1.
 - d.** Install the fuel tank in accordance with EMEI Vehicle G 103 – Group 4.
 - e.** Install the steering column in accordance with EMEI Vehicle G 104-1 – Group 14.
 - f.** Install the dashboard in accordance with EMEI Vehicle G 104-2 – Group 17.
 - g.** Install the brake servo cylinder and pedal bracket in accordance with EMEI Vehicle G 103 – Group 12.
 - h.** Install the clutch master cylinder and pedal bracket in accordance with EMEI Vehicle G 103 – Group 5.
 - i.** Install the heater assembly in accordance with EMEI Vehicle G 103 – Group 18.
 - j.** Attach the lifting sling to the firewall windscreen mounting holes.
 - k.** Using the lifting equipment, position the firewall on the chassis frame.
 - l.** Install the bolts, washers and nuts that retain the firewall to the outriggers, and tighten them securely.
 - m.** Remove the sling and lifting equipment.
 - n.** Using suitable overhead lifting equipment, with a minimum safe working load of 500 kg, position the body assembly on the chassis frame.
 - o.** With the weight of the body still supported by the lifting equipment, ensure that all the mounting brackets are positioned correctly.
 - p.** Fit the bolts, washers and nuts that secure the brackets to the chassis frame, but do not tighten them at this stage.
 - q.** Remove the slings and lifting equipment.
 - r.** Install the eight nuts, washers and bolts, retaining the body mounting brackets to the chassis frame outrigger, (Figure 21) and tighten them securely.
 - s.** Repeat the procedure for the opposite side, and tighten all remaining body mounting bolts securely.
 - t.** Install the battery earth cable on the left side outrigger, and tighten the retaining bolt, washer and nut securely.
 - u.** Install the bolts that secure the toe-box brackets to the chassis (Figure 22).

- v. Install the bolts securing the front body mountings to the chassis brackets (Figure 20) and tighten them securely.
- w. Install the nuts, washers and bolts retaining the rear body restraining stays (Figure 19).
- x. Install the nuts, washers and bolts retaining the rear body support brace to the chassis frame (Figure 18).
- y. Install the jerrican holders on the chassis, fit the bolts, washers and nuts and tighten them securely.
- z. Install the parking brake cable in accordance with EMEI Vehicle G 103 – Group 12.
- aa. Install the front seats and runners and tighten the retaining bolts securely in accordance with EMEI Vehicle G 103 – Group 17.
- bb. Fit the fuel tank breather and filler neck hoses and tighten the hose clamps securely in accordance with EMEI Vehicle G 143 – Group 4.
- cc. Connect the steering column at the firewall in accordance with EMEI Vehicle G104-1 – Group 14.
- dd. Connect the main wiring harness at the firewall in accordance with EMEI Vehicle G104-2 – Group 15.
- ee. Install the speedometer cable in accordance with EMEI Vehicle G 103 – Group 6.
- ff. Connect the axle and gearbox breather hoses and tighten the banjo bolts securely in accordance with EMEI Vehicle G 103 – Group 6.
- gg. Install the exhaust system in accordance with EMEI Vehicle G 103 – Group 3.
- hh. Install the windscreen in accordance with EMEI Vehicle G 103 – Group 17.
- ii. Using suitable overhead lifting equipment, with a minimum safe working load of 500 kg, install the upper body panels onto the vehicle.
- jj. Fit the ten bolts, nuts and washers that retain the upper body panels to the lower body frame (Figure 14) and tighten them securely.
- kk. Fit the four screws that secure the roof panel to the top of pillars B (Figure 13) and C (opposite side of vehicle).
- ll. Fit a new sealing strip to the top of the windscreen frame.
- mm. Install the eight bolts that secure the roof panel (Figure 13) to the windscreen frame.
- nn. Install the rear and inward facing seats in accordance with EMEI Vehicle G 143 – Group 17.
- oo. Install the sill panels and stays (Figure 12), and secure them with the bolts, nuts and washers.
- pp. Fit the wheel arch extensions on the sills and secure them with the plastic clips.
- qq. Install the rear floor panel and secure it with the eleven screws.
- rr. Install the rear cargo area mat and tighten the mat retaining plate bolts.
- ss. Install the front floor panels in accordance with EMEI Vehicle G 103 – Group 17.
- tt. Install the rear mat and retaining plates (Figure 11) and secure them with the three screws.
- uu. Install the rear doors in accordance with EMEI Vehicle G 143 – Group 17.
- vv. Install the front doors in accordance with EMEI Vehicle G 143 – Group 17.
- ww. Install the radiator in accordance with EMEI Vehicle G 103 – Group 2.
- xx. Install the grille in accordance with EMEI Vehicle G 103 – Group 17.
- yy. Install the mudguards in accordance with EMEI Vehicle G 104-1 – Group 17.
- zz. Install the bonnet in accordance with EMEI Vehicle G 104-1 – Group 17.
- aaa. Install the winch and fairlead in accordance with EMEI Vehicle G 104-1 – Group 19.
- bbb. Install the brushguard in accordance with EMEI Vehicle G 103 – Group 16.
- ccc. Connect the wiring harness to the interior light unit and install the lens.
- ddd. Fit both windscreen wiper arms and blades.

- eee.** Connect the Cannon plug onto the 28-volt alternator output and secure the electrical harness to the left side inner wheel arch inner panel in accordance with EMEI Vehicle G 143 – Group 15.
- fff.** Install the batteries (24-volt installation) and cables in accordance with EMEI Vehicle G 143 – Group 15 securing the electrical harness to the chassis crossmember with cable ties.
- ggg.** Install the vehicle battery (12-volt installation) and cables in accordance with EMEI Vehicle G 103 – Group 15.

Tropical Roof

- 24. Removal.** Using a suitable drill, remove the twenty four rivets securing the tropical roof to the roof panel, then remove the tropical roof.
- 25. Cleaning and Inspection.** Inspect the tropical roof for:
 - a. Roof Panel Damage.** Inspect the roof within a 100 mm diameter circle centered on the securing rivet hole for damage, cracks or any other weakness that could reduce the ability of the rivet to adequately secure the roof to the vehicle. If the roof fails inspection it is to be replaced.
 - b. The Number of Rivets and Vacant Holes.** The total number of rivets and vacant holes is not to exceed forty eight. The total number of rivets is not to be less than twenty four. The leading edge of the roof is to be secured by a minimum of six rivets. If the roof does not meet these criteria it is to be replaced.
 - c. Correct Rivets.** Rivets that cannot be confirmed as correct are to be replaced. New rivets are made of aluminium, have a stem diameter of 5.3 mm, and a length of 21.7 mm. Rivets that have not been fitted should have three slits in the stem to assist with the mushrooming action when they are installed. When fitted to a vehicle they can be identified by measuring the head diameter which should be 11.5 mm and head thickness of 2 mm.
 - d. Loose Rivets.** Rivets that appear loose are to be removed and replaced. Replacement rivets are to be fitted to existing holes except where the hole diameter exceeds 6.0 mm. If an existing hole cannot be used, a new 5.3 to 5.4 mm diameter hole is to be drilled 25 mm away from the original hole on the centre line of the stiffener rail. The correct type of replacement rivets are to be fitted in the new hole and any unused or old holes filled with translucent silicone sealer and smoothed off.
 - e. Roof Replacement.** If a tropical roof panel has been removed for replacement, the condition of the pop rivet holes in the longitudinal stiffener rails must be inspected before they are used to attach the new panel. Existing holes are not to be reused if they are greater than 6.0 mm diameter. If required, mark the position of the new hole 25 mm away from the original hole along the centre line of the stiffener rail. Mark the corresponding position on the new panel and drill a 5.3 to 5.4 mm diameter hole through both the panel and stiffener rail when the panel has been positioned on the vehicle.
- 26. Installation.** Position the tropical roof on the roof panel, aligning the rivet holes, and then secure the tropical roof with new pop rivets.

UNCONTROLLED IF PRINTED

END

Distribution List: **VEH G 16.6 – Code 3** (Maint Level)
(Sponsor: LV, SPO, Lt B Vehicles)
(Authority: TRAMM)