

**TRUCK, UTILITY, LIGHTWEIGHT, FFR, MC2 - LANDROVER 110
TRUCK, UTILITY, LIGHTWEIGHT, FFR, WINCH, MC2 - LANDROVER 110**

LIGHT GRADE REPAIR

This instruction is authorised for use by command of the Chief of Army. It provides direction, mandatory controls and procedures for the operation, maintenance and support of equipment. Personnel are to carry out any action required by this instruction in accordance with EMEI General A 001.

TABLE OF CONTENTS

	Page no		Page no
Introduction	3	Alternator (28 Volt).....	8
Associated Publications	3	Wiring Harness	9
Location Of Identification Numbers	5	Batteries (28 Volt Installation).....	11
List Of Lubricants	5	Interior Lamps.....	12
Engine - Group 1	6	Interior Lamps Switch	13
Jockey Pulley	6	Hour Meter Or Amp Gauge Replacement	13
Cooling System – Group 2.....	7	Electrical System Fault Finding (28 Volt).....	14
Fanbelts	7	Body - Group 17	15
Engine And Cooling Group Specifications	8	Roll Over Protection.....	15
Electrical – Group 15	8		

LIST OF FIGURES

	Page No		Page No
Figure 1 Jockey Pulley Exploded View	6	Figure 5 Batteries Installation	10
Figure 2 Fanbelt Replacement.....	7	Figure 6 Left Side Battery Compartment	11
Figure 3 Alternator Installation	9	Figure 7 Interior Lamps Exploded View.....	12
Figure 4 Rear Wiring Harness (FFR)	10	Figure 8 Instrument Panel Removal	13

LIST OF TABLES

	Page No		Page No
Table 1 Location Of Identification Numbers	5	Table 3 Engine And Cooling Group Specifications.....	8
Table 2 List Of Lubricants	5	Table 4 Electrical System Fault Finding (28 Volt).....	14

UNCONTROLLED IF PRINTED

UNCONTROLLED IF PRINTED

Blank Page

INTRODUCTION

1. This EMEI contains procedures for removing, dismantling, repairing, assembling and installing various components of the Truck, Surveillance, Lightweight, with winch. Where applicable, instructions for the adjustment, lubrication and minor servicing of these items are included.



Do not use adhesive tapes to seal fuel or oil openings. The adhesive tape is soluble in fuel or oil and can cause contamination. Remove temporary covers before assembling.

2. Prevent dirt and foreign objects from entering any component by placing clean temporary coverings over all exposed openings, including hoses, tubes and lines.

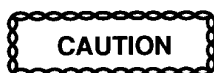

Before removing any electrical system components, disconnect the battery leads.

3. When disconnecting electrical connectors, hoses and fittings, remove clamps as required, to gain slack and avoid damage to connectors and fittings.

4. Discard all used gaskets, seals, cotter pins, tab washers, lock pins, key washers and lock washers. Discard all contaminated fuel and lubricants drained from the truck.

5. Use only those fuels and lubricants specified in the Servicing Instruction, EMEI Vehicle G 109, the User Handbook and this EMEI when replenishing fuel or lubricants.

6. Any fastenings or fittings being tightened to prescribed torques are to have dry, clean threads unless otherwise specified. When specified, thread sealants are to be applied to dry, clean, oil free threads.

7. The engine cooling system contains Nalcool corrosion inhibitor in water at a ratio of 1:12.



Precautions should be taken prior to carrying out repairs which include painting, sanding, scraping or welding. Refer to EMEI Workshop D 701 – Repair Policy for Equipment Painted in Polyurethane Paint.

8. This vehicle is painted in polyurethane paint.

Associated Publications

9. Reference may be necessary to the latest issue of the following documents:

a. Defence Road Traffic Instructions;

b. Complete Equipment Schedules (CES):

(1) Truck, Utility, Lightweight, FFR, MC2 – Land Rover 110;

(a) SCES 12038, and

(b) Equipment Kit SCES 12036.

(2) Truck, Utility, Lightweight, FFR, MC2, W/Winch – Land Rover 110;

(a) SCES 12039, and

(b) Equipment Kit SCES 12036.

c. Block Scale 2406/31 – Special Tools for RAEME – B Vehicles – Truck, Utility and Truck, Light, MC2 (Land Rover Model 110);

- d. EMEI Electrical P 410 – Generator Engine Accessory 28 Volt–100 Ampere – Data Summary;
 - e. EMEI Vehicle A 029 – Vehicles General – Servicing of B Vehicles, Trailers, Stationary Equipment, Auxiliary and Small Engines;
 - f. EMEI Vehicle A 291-5 – General Service B Vehicles Tyre Guide – Operating Instruction;
 - g. EMEI Vehicle G 008-1 – Truck, Lightweight, MC2, All Types – Inspection Of Towing Pintle Assembly;
 - h. EMEI Vehicle G 103 – Truck, Utility, Lightweight , MC2, Land Rover 110 and Truck, Utility, Lightweight, W/Winch, MC2, Land Rover 110 – Light Grade Repair;
 - i. EMEI Vehicle G 109 – Truck, Lightweight, MC2, Land Rover 110 4X4, All Types – Servicing Instruction;
 - j. EMEI Vehicle G 110 – Truck, Utility, Lightweight, FFR and Truck, Utility, Lightweight, FFR, W/Winch, MC2, Land Rover 110 4X4 – Data Summary;
 - k. EMEI Vehicle G 112 – Truck, Utility, Lightweight, FFR, MC2, Land Rover 110 and Truck, Utility Lightweight, FFR, W/Winch, MC2, Land Rover 110 – Technical Description;
 - l. EMEI Vehicle G 114-1 – Truck, Utility, Lightweight, FFR, MC2, Land Rover 110 and Truck, Utility, Lightweight, FFR, W/Winch, MC2, Land Rover 110 – Medium and Heavy Grade Repair;
 - m. EMEI Workshop D 701 – Repair Policy for Equipment Painted in Polyurethane Paint;
 - n. RPS 02190; and
 - o. RPS 02191 (Winch).
10. A number of modifications and improvements have been made during the service life of the vehicle. Reference to the following publications may be required during repair activities:

NOTE

Any effect of these publications pertaining to the technical content of this document has been included in the text.

- a. EMEI Vehicle G 117-1 – Truck, Utility, Lightweight, FFR, MC2, Land Rover 110 and Truck, Utility Lightweight, FFR, W/Winch, MC2, Land Rover 110 – Roll Over Protection and Fitting of Head Restraints;
- b. EMEI Vehicle G 117-2 – Truck, Utility, Lightweight, FFR, MC2, Land Rover 110 and Truck, Utility, Lightweight, FFR, W/Winch, MC2, Land Rover 110 – Relocation of Raven Radio Frame Mountings;
- c. EMEI Vehicle G 117-3 – Truck, Panel, Lightweight, FFR, MC2, Land Rover 110 and Truck, Utility Lightweight, FFR, W/Winch, MC2, Land Rover 110 – Number Plate Light Protection;
- d. EMEI Vehicle G 117-4 – Truck, Utility, Lightweight, FFR and FFR W/Winch, MC2, Land Rover 110 4X4 – Reinforcement of Rear Canopy Bow for Air Portability of Vehicles Fitted With Interim Gunnery Computer; and

WARNING

All industrial safety, work practices and equipment operating and maintenance instructions pertaining to this EMEI are to be adhered to.

The handling, storage and use of chemical substances are to be in accordance with MOHS, MSDS and EMEI Workshop series requirements.

Location of Identification Numbers

11. The location of identification numbers on components of the vehicle is described in Table 1.

Table 1 Location Of Identification Numbers

Serial	Identification Number	Location
1	Chassis number	Right hand side of the chassis, forward of the spring mounting turret
2	Chassis nameplate	Left hand seat box, in the cab
3	Engine number	Left hand side of the engine block
4	Injection pump identification	Side of the pump
5	Transmission and transfer case	Rear of the transfer case
6	Torque limiter	On rear end of the drive plate
7	Front axle number	Adjacent to the axle breather
8	Rear axle number	Adjacent to the axle breather

NOTE

NSN and Manufacturers part numbers and designations used in this EMEI were current at the date of issue. If twelve months or more have expired since the date of issue, the NSN and Manufacturers part number should be checked for supersession.

List of Lubricants

12. The lubricants used on the vehicle are listed in Table 2.

Table 2 List Of Lubricants

Serial	Equipment	Lubricant	Capacity (litres)
1	Engine (including filter)	OMD-115	8.5
2	Transmission	OMD-115	2.7
3	Transfer case (with PTO)	OMD-115	5.8
4	Front differential	OEP-220	1.7
5	Rear differential	OEP-220	2.3
6	Swivel pin housings	Molytex grease	EP00 Sachet
7	Brake master cylinder	OX (Aust) 8	Fill to level
8	Clutch master cylinder	OX (Aust) 8	Fill to level
9	Steering box	OEP-220	0.45
10	Fanbelt jockey pulley	XG-274	As required
11	Wheel bearings	XG-274	As required
12	Winch rope	Rocol wire rope lube NSN 9510-66-150-1763	As required
13	Radiator inhibitor	Nalcool	As required (1:12 ratio)
14	Propeller shaft	XG-274	As required
15	Winch drive line	XG-274	As required
16	Winch	OEP-220	1.3

UNCONTROLLED IF PRINTED

ENGINE - GROUP I

Jockey Pulley

13. **Removal.** Remove the jockey pulley as follows:

- a. Slacken the adjusting bolt on the pulley arm (refer Figure 1).

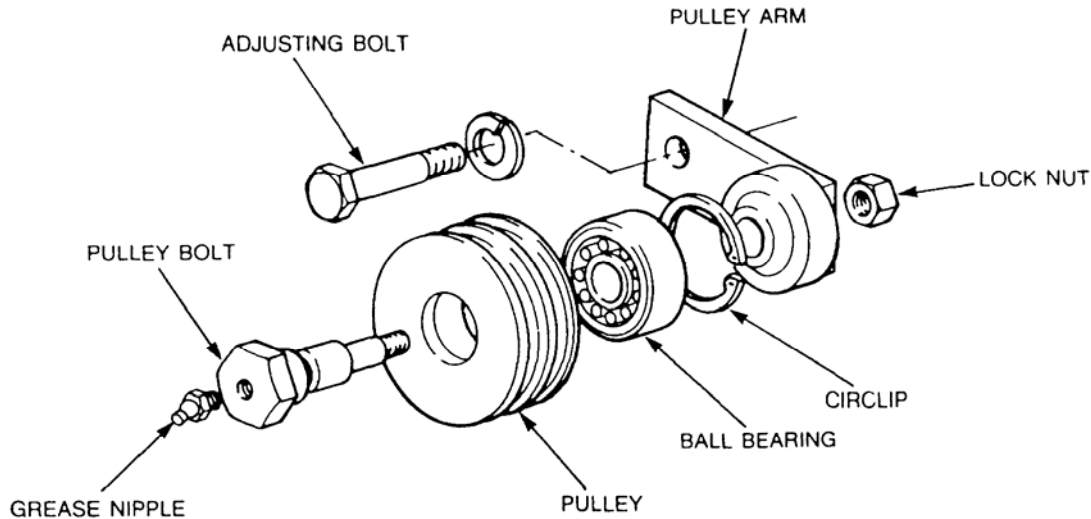

Figure 1 Jockey Pulley Exploded View

- b. Detach the two fanbelts from the pulley.
 - c. Remove the adjusting bolt from the pulley arm and mounting.
 - d. Remove the pulley arm and pulley from the engine.
14. **Disassembly.** Disassemble the jockey pulley as follows:
- a. Remove the grease nipple from the pulley bolt.
 - b. Secure the pulley arm in a vice.
 - c. Remove and discard the lock nut securing the pulley bolt.
 - d. Remove the pulley bolt and pulley.
 - e. Remove the internal circlip retaining the bearing in the pulley.
 - f. Remove the bearing from the pulley.
 - g. Clean and degrease the pulley.
15. **Reassembly.** Reassemble the jockey pulley as follows:
- a. Install the bearing in the pulley.

NOTE

Ensure that the chamfered face is installed first.

- b. Insert the circlip into the pulley.
 - c. Install the pulley on the pulley arm with the circlip facing the arm boss.
 - d. Insert the pulley bolt and a new lock nut.
 - e. Install the grease nipple and lubricate with XG-274.
16. **Installation.** Install the jockey pulley as follows:
- a. Align the pulley arm bolt hole with the mounting hole.
 - b. Insert the adjusting bolt.

- c. Fit the two fanbelts in the pulley grooves.
- d. Position the pulley arm to allow a deflection of 5–10 mm on the longest span of the belts.
- e. Tighten the adjusting bolt securely.

COOLING SYSTEM – GROUP 2

Fanbelts

17. **Replacement.** Replace the fanbelts as follows:
- a. Slacken the adjusting bolt on the pulley arm (refer Figure 1).
 - b. Detach the two fanbelts from the pulley.
 - c. Remove the two 28 volt alternator fanbelts from the crankshaft pulley.
 - d. Loosen the 12 volt alternator mounting bolts and adjusting bolt (refer Figure 2).

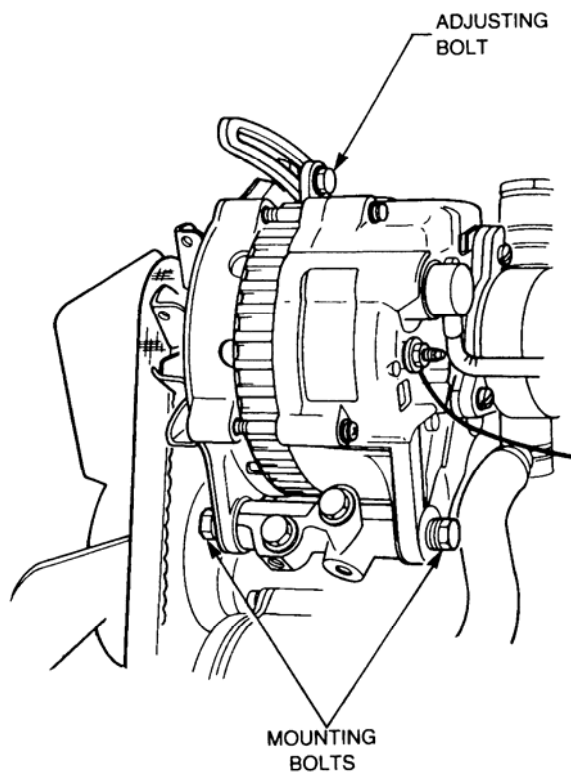

Figure 2 Fanbelt Replacement

- e. Detach the fanbelt from the 12 volt alternator drive pulley.
- f. Remove all three fanbelts from the engine.
- g. Install the inner fanbelt.

NOTE

- Ensure that all three drive pulleys are correctly located.
- h. Swing the 12 volt alternator away from the engine.
- i. Check the tension of the belt by applying moderate thumb pressure to the longest span of the belt.
- j. When a belt deflection of 10–15 mm has been obtained, tighten the adjusting bolt.
- k. Tighten the mounting bolts.

- l. Install the remaining two fanbelts and ensure that the belts are correctly located on the pulleys.
- m. Position the pulley arm to allow a deflection of 5–10 mm on the longest span of the belts.
- n. Tighten the adjusting bolt securely.

Engine And Cooling Group Specifications

18. The engine and cooling group specifications are detailed in Table 3.

Table 3 Engine And Cooling Group Specifications

Serial	Description	Item	Specification
1	Fan belt deflection	12 volt alternator	10–15 mm
		28 volt alternator	5–10 mm

ELECTRICAL – GROUP 15

Alternator (28 Volt)

19. **Removal.** Remove the 28 volt alternator as follows:
- a. Disconnect the vehicle and FFR system batteries.
 - b. Cut the lock wire securing the cannon plug to the 28 volt alternator.
 - c. Remove the cannon plug.
 - d. Slacken the adjusting bolt on the pulley arm (refer Figure 1).
 - e. Detach the two fanbelts from the pulley.

WARNING

The 28 volt alternator is heavy. Care must be taken when removing the alternator or personal injury may result.

- f. Support the alternator, then remove the bolts that retain the alternator clamp rings to the mounting.
- g. Carefully remove the alternator from the vehicle.
- h. Discard the lock washers.
- i. Remove the bolts, nuts and washers that secure the clamp rings on the alternator.
- j. Remove the clamp rings.
- k. Discard the lock washers.

NOTE

Repair procedures for the 28 volt alternator are detailed in EMEI Electrical P 410 series.

20. **Installation.** Install the 28 volt alternator as follows:
- a. Fit the clamp rings onto the alternator and install the bolts, nuts and washers (refer Figure 3).

NOTE

Do not tighten at this stage.

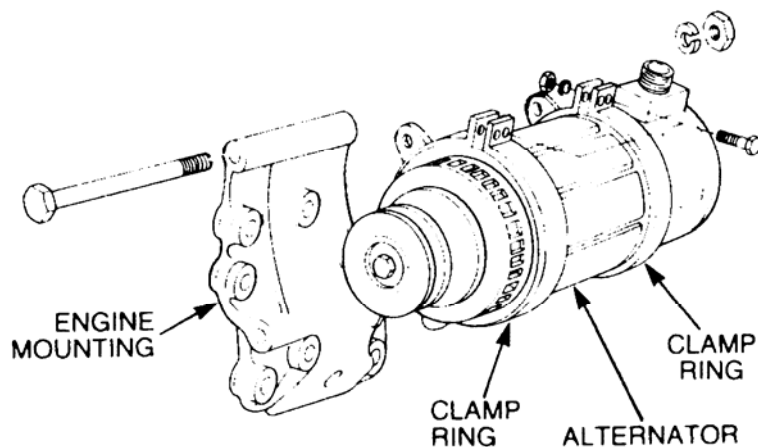

Figure 3 Alternator Installation

WARNING

The 28 volt alternator is heavy. Care must be taken on installation or personal injury may result.

- b. Support the alternator and clamp rings beside the engine mounting.
- c. Insert the bolts that secure the clamp rings to the mounting.
- d. Install the nuts and new lock washers and tighten securely.

NOTE

Ensure that the alternator and crankshaft pulleys are aligned by using a suitable straight edge.

- e. Connect the cannon plug,
- f. Tighten the nuts on the clamp rings securely.
- g. Fit the two fanbelts in the pulley grooves.
- h. Position the pulley arm to allow a deflection of 5–10 mm on the longest span of the belts.
- i. Tighten the adjusting bolt securely.
- j. Lock wire the cannon plug to the 28 volt alternator.
- k. Connect the vehicle and FFR system batteries.

Wiring Harness

21. **General Precautions.** Exercise the following precautions when working on the wiring harness:

CAUTION

Arcing wires to earth, to determine if the wire is live, will destroy solid state components.

- a. Use suitable testing meters or circuit testers to trace or locate faults and check circuits.
- b. After tracing electrical faults, before carrying out any electrical repairs, disconnect the batteries, negative terminals first.

CAUTION

Failure to disconnect the alternators will cause the transistors and diodes to fail as a result of current flow throughout the chassis when arc welding.

- c. Before carrying out any electrical arc welding on the vehicle, disconnect the batteries and both alternators.

CAUTION

Reversing battery polarity will cause serious damage.

- d. When installing the batteries, ensure that the terminals are connected to the correct posts.
- e. The layout of the rear wiring harness for a vehicle fitted for radio is shown in Figure 4.

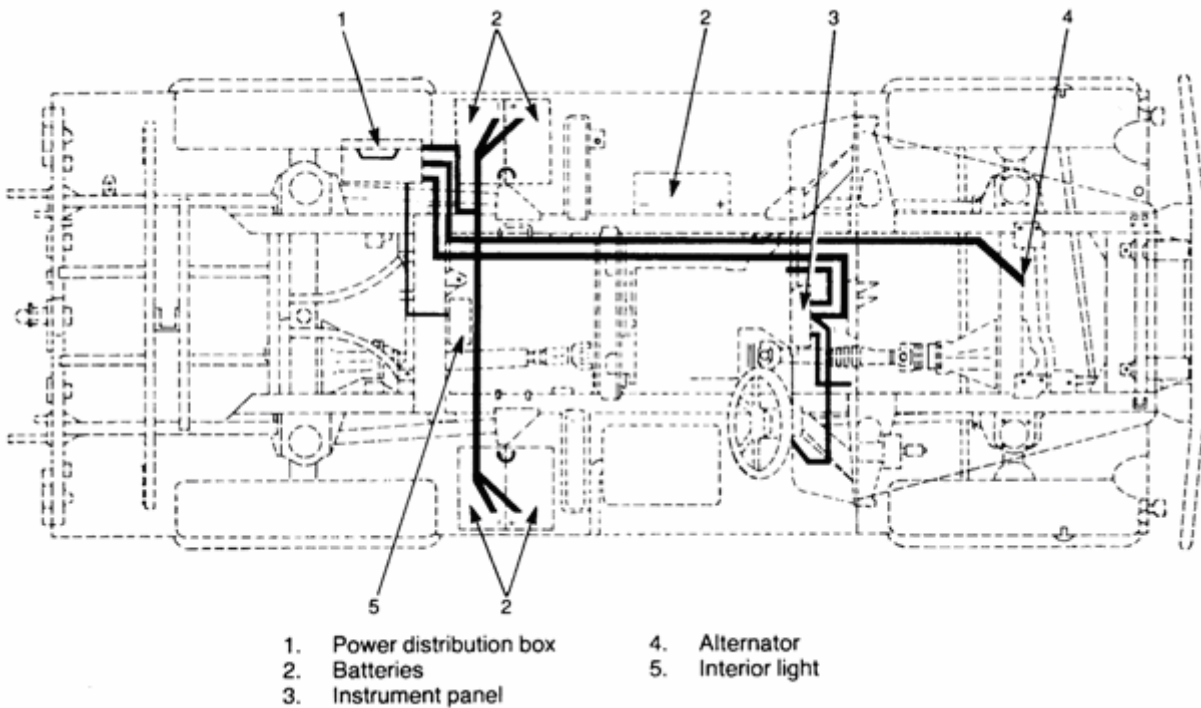

Figure 4 Rear Wiring Harness (FFR)

22. Replacement. Replace the wiring harness as follows:

- a. Disconnect the batteries, negative terminals first (refer Figure 5).

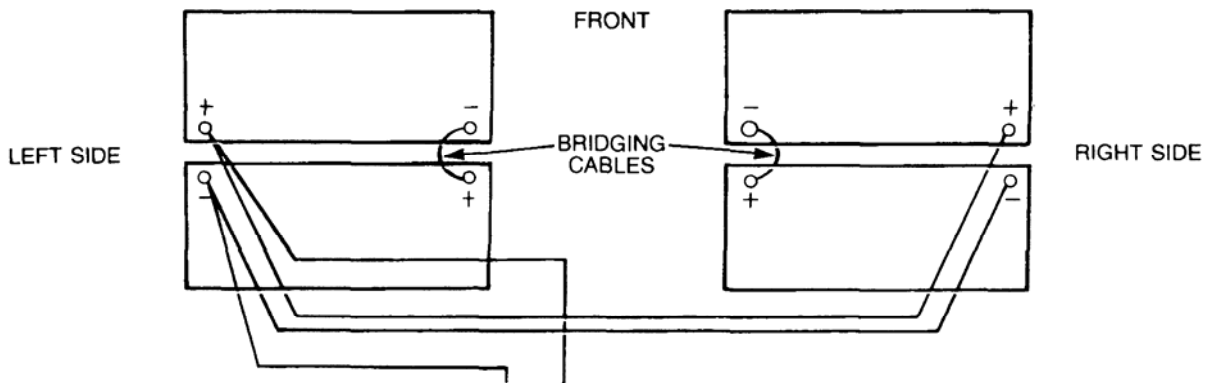

Figure 5 Batteries Installation

UNCONTROLLED IF PRINTED

NOTE

All electrical wiring in the vehicle is colour coded for identification and reference. If necessary, refer to the wiring diagram in EMEI Vehicle G 103, in conjunction with the relevant illustration, when replacing a wiring harness.

- b. Determine which harness is to be replaced and ensure that the replacement harness is of the correct capacity and that the wires are correctly colour coded.
- c. Using the old harness and tags as a guide, connect the wires to the appropriate terminals.
- d. Reconnect the batteries.
- e. Test the function of the components associated with the wiring harness that has been replaced to ensure correct function.

Batteries (28 Volt Installation)

23. Replacement. Replace the batteries (28 volt installation) as follows:

- a. Switch off the master switch on the power distribution box.
- b. Remove the security clip and pin from the left hand battery carrier (refer Figure 6).

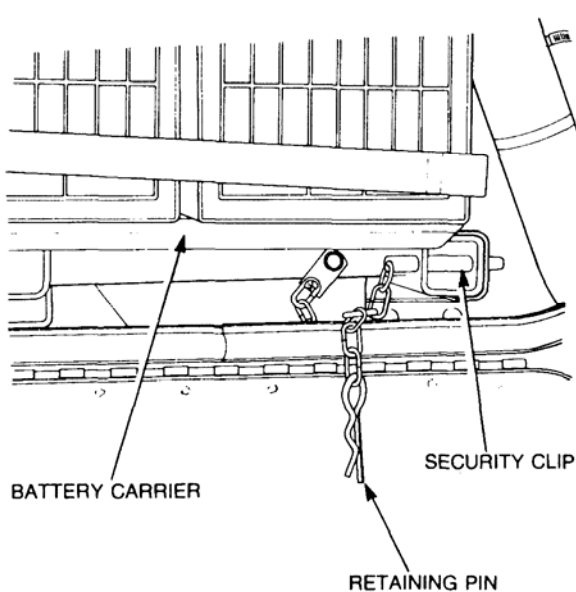

Figure 6 Left Side Battery Compartment

- c. Slide the batteries and carrier clear of the vehicle body, until the small bridging cable is exposed.
- d. Disconnect the bridging cable from both the positive and negative terminals on the batteries.
- e. Remove the bridging cable.
- f. Repeat the procedure (detailed in sub-paragraphs b to e) for the batteries installed on the right side of the vehicle.
- g. Disconnect the remaining cables from the batteries.
- h. Remove the nuts and washers securing the battery retaining bracket.
- i. Remove the battery retaining bracket.
- j. Lift the batteries out of the battery carrier.
- k. Install the batteries in the battery carrier.

NOTE

Ensure that the batteries are installed correctly (refer Figure 5).

- l. Secure the batteries with the retaining bracket.
- m. Connect the battery cables and stow the battery carriers.
- n. Secure the battery carriers with the security clip and pin.
- o. Switch on the master switch on the power distribution box.

Interior Lamps

24. **Bulb Replacement.** Replace the bulb in the interior lamps as follows:

NOTE

The interior lamps are located in the vehicle roof in the rear of the vehicle. There are two lens assemblies, one white and one red. Before proceeding determine which assembly is faulty. The interior lamp switch is a single pole double throw switch. The centre position of the switch is the OFF position. The ON positions will switch either the red or white light assembly.

- a. Remove the two screws securing the lens (refer Figure 7).

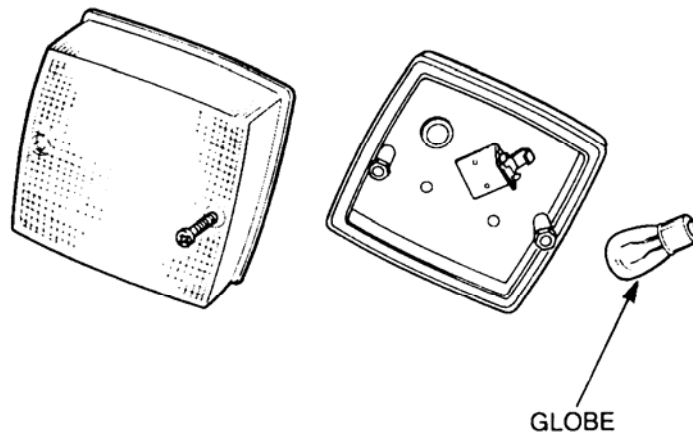

Figure 7 Interior Lamps Exploded View

- b. Remove the lens.
- c. Remove the bulb.
- d. Install a new bulb.

CAUTION

Do not over tighten the lens screws as the lens may crack

- e. Replace the lens.

25. **Lamp Unit Replacement.** Replace the lamp unit as follows:

- a. Remove the two screws securing the lens.
- b. Remove the lens.
- c. Tag and disconnect the lamp harness from the lamp switch.
- d. Remove the two nuts and washers securing the lamp unit to the mounting panel.
- e. Remove and discard the lamp unit.
- f. Position the new lamp unit on the mounting panel.

- g. Secure with the two nuts and washers.
- h. Install the lens.
- i. Secure with the two lens screws.
- j. Connect the lamp harness to the lamp switch.

Interior Lamps Switch

26. **Replacement.** Replace the interior lamps switch as follows:

- a. Disconnect the batteries.
- b. Tag and disconnect the lamp and wiring harnesses from the lamp switch.
- c. Remove the nut securing the switch to the mounting panel.
- d. Remove and discard the switch.
- e. Position the new lamp switch on the mounting panel.
- f. Secure with the nut.
- g. Connect the wiring harnesses to the lamp switch.
- h. Connect the batteries.

Hour Meter or Amp Gauge Replacement

27. **Removal.** Remove the faulty gauges as follows:

- a. Disconnect the batteries.
- b. Remove the four screws securing the instrument panel to the trim panel (refer Figure 8).

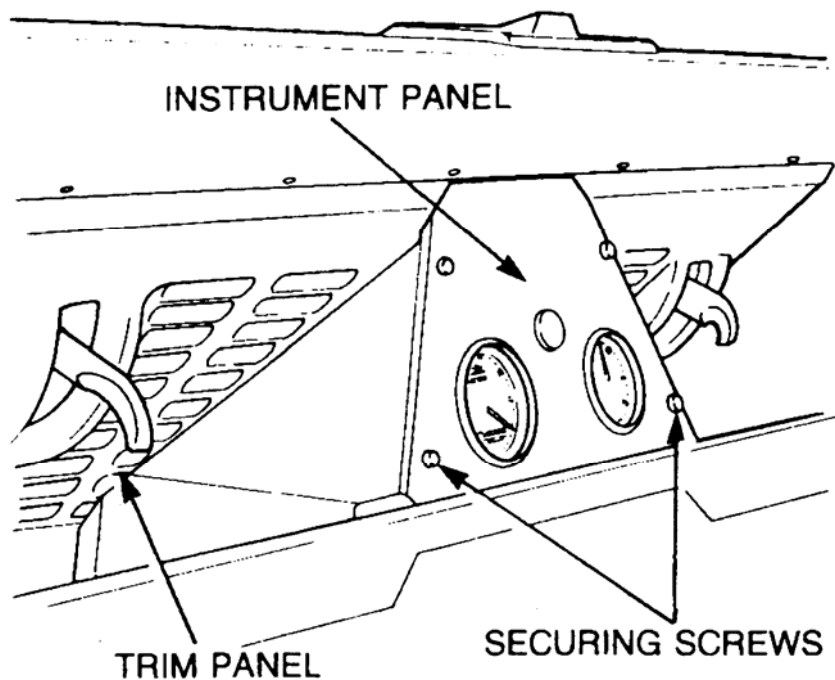

Figure 8 Instrument Panel Removal

- c. Ease the instrument panel away to allow access to the wiring harness.
- d. Tag and disconnect the wiring harness from the gauge to be removed.
- e. Remove the two nuts and clamp plate securing the gauge to the panel.
- f. Remove the faulty gauge.

28. **Installation.** Install the replacement gauges as follows:

- a. Fit the gauge into the instrument panel.
- b. Secure the gauge with the two nuts and clamp plate.
- c. Connect the wiring harness to the gauge.

NOTE

Ensure that the connectors are fitted to the correct terminals.

- d. Fit the instrument panel to the trim panel.
- e. Secure the instrument panel with the four screws.
- f. Connect the batteries.

Electrical System Fault Finding (28 Volt)

29. The procedures for electrical system fault finding (28Volt) are detailed in Table 4.

Table 4 Electrical System Fault Finding (28 Volt)

Serial	Symptom	Probable Cause	Action
1	Low reading on ammeter.	Loose fan belt.	Tighten to correct tension.
		Defective regulator.	Test / replace end bell assembly.
		Poor connection in charging circuit.	Rectify.
		Defective batteries.	Replace defective batteries.
		Defective rectifier.	Test / replace end bell assembly.
2	No reading on ammeter.	Open circuit regulator sensing line.	Test / rectify defective sensing line switch or relay.
		Defective fan belt.	Replace fan belt.
		Loose or disconnected Cannon plug.	Tighten plug.
		Open circuit in main circuit.	Test / rectify defect.
		Defective regulator.	Test / replace end bell assembly.
		Open circuit in RF filter capacitor(s).	Test / replace end bell assembly.
		Disconnected field leads.	Refit / tighten plugs.
		Open circuit batteries.	Test / replace batteries.
Defective relay.	Test / replace relay.		
3	Alternator overheating.	Defective connection resulting in arcing.	Tighten connections.
		Restricted or blocked air grille.	Clean air grille.
		Alternator delivering maximum continuous output.	Check regulator sensing line for high resistance or poor connection.
		Defective regulator.	Test / replace end bell assembly.
		Rectifier diode(s) defective.	Test / replace end bell assembly.
		Defective batteries.	Test / replace batteries.
4	Alternator noisy.	Defective bearings.	Replace alternator.
		Loose fan or pulley.	Rectify.
		Loose alternator mountings.	Rectify.
		Defective rectifier.	Test / replace end bell assembly.

UNCONTROLLED IF PRINTED

Table 4 Electrical System Fault Finding 28 Volt (Continued)

Serial	Symptom	Probable Cause	Action
5	Intermittent overcharging	High resistance or poor connection in regulator sensing line.	Rectify.
		Defective regulator.	Test / replace end bell assembly.
		Loose battery terminals.	Rectify.
6	No reading on battery condition indicator when master switch is in the ON position.	Defective indicator.	Replace indicator.
		Open circuit in the power distribution box wiring harness.	Rectify.
		Defective fuse.	Replace fuse.
		Defective circuit breaker in the power distribution box.	Replace circuit breaker.
		Loose battery terminals.	Rectify.
7	Low reading on battery condition indicator when master switch is in the ON position.	Defective batteries.	Test / replace batteries.
		Defective indicator.	Replace indicator.
8	Hour meter not working.	Defective hour meter.	Replace hour meter.
		Open circuit in hour meter wiring.	Rectify.

BODY - GROUP 17

Roll Over Protection

WARNING

The roll over protection structure is to be replaced should any of the following occur:

- the vehicle has been involved in a roll over accident;**
- distortion has occurred to the roll over structure or capping rails; or**
- weld failure occurs.**

- 27.** Refer to EMEI Vehicle G 117-1 for fitting instructions.
- 28.** Some vehicles have had the rear canopy bow reinforced to enhance air portability of vehicles fitted with the Interim Gunnery Computer. Refer to EMEI Vehicle G 117-4 for reinforcement instructions.

END

Distribution List: **VEH G 16.2 – Code 2** (Maint Level)
(Sponsor: LV SPO, Light B Vehicles)
(Authority: TRAMM)