

**TRUCK, SURVEILLANCE, LIGHTWEIGHT, W/WINCH, W/SIDE STOWAGE, W/REAR SEAT, MC2 – LAND ROVER 110 4X4**

**MEDIUM AND HEAVY GRADE REPAIR**

This instruction is authorised for use by command of the Chief of Army. It provides direction, mandatory controls and procedures for the operation, maintenance and support of equipment. Personnel are to carry out any action required by this instruction in accordance with EMEI General A 001.

**TABLE OF CONTENTS**

	<b>Page No</b>		<b>Page No</b>
General.....	3	Steering Box .....	6
Introduction .....	3	Power Steering System Test .....	9
Associated Publications .....	3	Body .....	11
Safety Precautions .....	4	Rollover Protection .....	11
Authorised Personnel.....	4	Cargo Tray Bins.....	11
Maintenance Supply Serial (MSI) Identification .....	5	Heavy Grade Repair .....	11
Special Tools and Gauges .....	5	Steering .....	11
Medium Grade Repair.....	6	Power Steering Pump.....	11
Steering .....	6	Steering Box .....	14

**LIST OF FIGURES**

	<b>Page No</b>		<b>Page No</b>
Figure 1 Removal of the Flexible Hoses to the Steering Box .....	7	Figure 11 Removal of the Bearing.....	13
Figure 2 Alignment of the Steering Column .....	7	Figure 12 Rack and Piston Retaining Ring Removal.....	15
Figure 3 Removal of the Tie Bar .....	8	Figure 13 Rack Pad Adjuster Removal.....	15
Figure 4 Removal of the Steering Box .....	8	Figure 14 Input Shaft and Bearings Removal.....	16
Figure 5 Installation of the Test Equipment.....	9	Figure 15 Removal of the Sector and Input Shaft Seals.....	16
Figure 6 Power Steering Pump Exploded View .....	12	Figure 16 Input Shaft Oil Seal Installation .....	17
Figure 7 Steering Pump Cover.....	12	Figure 17 Sector Shaft Oil Seals Installation .....	18
Figure 8 Cartridge and Coil Spring.....	12	Figure 18 Input Shaft Adjustment .....	18
Figure 9 Removal of the Drive Gear .....	13	Figure 19 Sector Shaft Installation.....	19
Figure 10 Removal of the Pump Shaft.....	13	Figure 20 Sector Shaft Adjustment.....	20

**LIST OF TABLES**

	<b>Page No</b>		<b>Page No</b>
Table 1 Location of Identification Numbers.....	5	Table 3 Power Steering Fault Finding .....	10
Table 2 Special Tools and Gauges .....	5	Table 4 Steering Specifications .....	20
Table 2 Special Tools and Gauges (Continued) .....	6	Table 4 Steering Specifications (Continued) .....	21

UNCONTROLLED IF PRINTED

UNCONTROLLED IF PRINTED

**Blank Page**

## GENERAL

### INTRODUCTION

1. This EMEI details all Medium and Heavy Grade Repair procedures for the Truck, Surveillance, Lightweight, W/Winch, W/Side Storage, W/Rear Seat, MC2 – Land Rover 110 4 × 4. For all other repairs refer to the relevant EMEI for the base variant vehicle.
2. Discard all used gaskets, seals, cotter pins, tab washers, lock pins, key washers and lock washers.
3. Use only those fuels and lubricants specified in the Servicing Instruction, EMEI Vehicle G 109, the User Handbook and this EMEI when replenishing fuel or lubricants.
4. Any fastenings or fittings being tightened to prescribed torques are to have dry, clean threads unless otherwise specified. When specified, thread sealants are to be applied to dry, clean, oil free threads.

### Associated Publications

5. Reference may be necessary to the latest issue of the following documents:
  - a. Block Scale 2406/31 – Special Tools for RAEME- B Vehicles – Truck, Utility and Truck, Light, MC2 (Land Rover Model 110);
  - b. Complete Equipment Schedules (CES):
    - (1) SCES TBA and;
    - (2) Maintenance Kit SCES 12142;
  - c. Defence Road Transport Instructions (DRTI);
  - d. Defence Safety Manual (SAFETYMAN);
  - e. [EMEI Vehicle A 291-5](#) – General Service B Vehicle Tyre Guide – Operating Instructions;
  - f. [EMEI Vehicle A 548-1](#) – Vehicle Seat Belts – Inspection for Usability;
  - g. [EMEI Vehicle G 090](#) – Truck, Surveillance, Lightweight, W/Winch, W/Side Stowage, W/Rear Seat, MC2, Land Rover 110 4x4 – Data Summary;
  - h. [EMEI Vehicle G 092](#) – Truck, Surveillance, Lightweight, W/Winch, W/Side Stowage, W/Rear Seat, MC2, Land Rover 110 4x4 – Technical Description;
  - i. [EMEI Vehicle G 093](#) – Truck, Surveillance, Lightweight, W/Winch, W/Side Stowage, W/Rear Seat, MC2, Land Rover 110 4x4 – Light Grade Repair;
  - j. [EMEI Vehicle G 098-1](#) – Truck, Surveillance, Lightweight, W/Winch, W/Side Stowage, W/Rear Seat, MC2, Land Rover 110 4x4 – Inspection for Useability;
  - k. [EMEI Vehicle G 103](#) – Truck, Utility, Lightweight, MC2, Land Rover 110 and Truck, Utility, Lightweight, W/Winch, MC2, Land Rover 110 – Light Grade Repair;
  - l. [EMEI Vehicle G 104-1](#) – Truck, Utility, Lightweight, MC2, Land Rover 110 and Truck, Utility Lightweight, W/Winch, MC2, Land Rover 110 – Medium Grade Repair;
  - m. [EMEI Vehicle G 104-2](#) Truck, Utility, Lightweight, MC2, Land Rover 110 and Truck, Utility Lightweight, W/Winch, MC2, Land Rover 110 – Heavy Grade Repair;
  - n. [EMEI Vehicle G 109](#) – Truck, Utility, Lightweight, MC2, Land Rover 110 4X4, All Types – Servicing Instruction;
  - o. [EMEI Workshop D 701](#) – Repair Policy for Equipment Painted in Polyurethane Paint;
  - p. [EMEI Workshop E 404](#) – Hazardous Substances – Chemical (HAZCHEM);
  - q. [EMEI Workshop E 410](#) – Occupational Health and Safety – Asbestos – General Instruction;
  - r. GM 120 – Record Book for Service Equipment – Army;
  - s. Material Safety Data Sheets (MSDS);
  - t. Repair Parts Scale (RPS) 02188;

- u. RPS 02290; and
- v. Current version of the Technical Regulation of Army Materiel Manual (TRAMM) (available from DTR-A website <http://intranet.defence.gov.au/armyweb/Sites/DTRA>).

### Safety Precautions

**WARNING**

**Precautions should be taken prior to carrying out repairs which include painting, sanding, scraping or welding. Refer to EMEI Workshop D 701 – Repair Policy for Equipment Painted in Polyurethane Paint.**

6. This vehicle is painted in polyurethane paint.

**WARNING**

**All industrial safety, work practices and equipment operating and maintenance instructions pertaining to this EMEI are to be adhered to.**

7. Protect the vehicle from dust and inclement weather when performing any of the tasks contained in this EMEI. If practical perform these tasks in a sheltered or enclosed area.

**CAUTION**

**Do not use adhesive tape to seal fuel or oil openings. The adhesive on most tapes is soluble in fuel or oil and can cause contamination. Remove temporary covers before assembling.**

8. Prevent dirt and foreign objects from entering any component. Place clean temporary covers on all exposed openings. All open hoses, tubes and lines are to be protected with plastic or metal caps or plugs.

**CAUTION**

**Isolate the vehicle batteries to prevent short circuits and overheating of electrical equipment before removing any electrical system components.**

9. When disconnecting electrical connectors, hoses and fittings, remove clamps as required, to gain slack and avoid damage to connectors and fittings.

**WARNING**

**The handling, storage, use and disposal of chemical substances, fuels and lubricants are to be in accordance with Safetyman, MSDS and EMEI Workshop E series requirements.**

10. Discard all contaminated fuel and lubricants drained from the vehicle in accordance with current instructions.

### Authorised Personnel

11. Repairs are to be carried out by the following technical tradespersons:
- a. Vehicle Mechanic ECN 229-2;
  - b. Technician Electrical ECN 418-2;
  - c. Metalsmith ECN 235-2; or

- d. civil equivalents qualified in accordance with the requirements of the TRAMM.

**Maintenance Supply Serial (MSI) Identification**

12. Table 1 lists the location of identification numbers on the MSI.

**Table 1 Location of Identification Numbers**

Serial	Identification Number	Location
1	Chassis number	Right-hand side of the chassis, forward of the spring mounting turret
2	Chassis nameplate	Left-hand seat box, in the cab
3	Engine number	Left-hand side of the engine block
4	Injection pump identification	Side of the pump
5	Transmission and transfer case	Rear of the transfer case
6	Torque limiter	On rear end of the drive plate
7	Front axle number	Adjacent to the axle breather
8	Rear axle number	Adjacent to the axle breather
9	Rollover protection	Front, lower centre of the front bar

**Special Tools and Gauges**



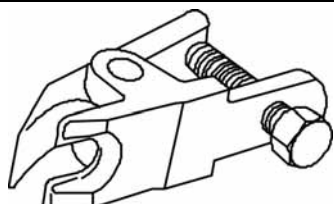
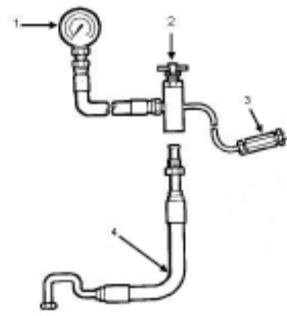
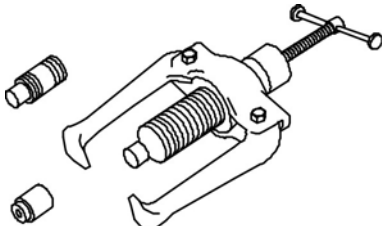

13. Table 2 lists the special tools, gauges and apparatus, required as indicated, to perform the Medium and Heavy Grade Repair tasks.

**Table 2 Special Tools and Gauges**

Serial	Part No	NSN	Name	Use	Illustration
1	LRT-57-018	5120-66-128-4304	Ball joint separator	Para 14 Medium Grade Repair	
2	JD 10 Comprising: 1. LRT-57-005 2. LRT-57-001 3. LRT-57-002 4. LRT-57-030	2530-66-128-4343 5130-99-767-3076 4910-99-726-1999	Power steering test set Pressure gauge Test adaptor Thread adaptor Hose	Para 16 Medium Grade Repair	
3	LRT-57-012		Steering arm remover	Para 23 Heavy Grade Repair	

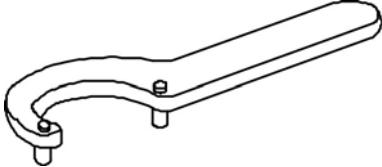
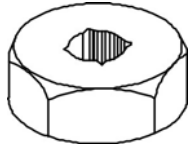
UNCONTROLLED IF PRINTED

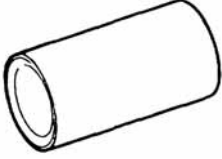
Table 2 Special Tools and Gauges (Continued)

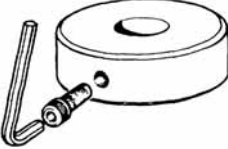
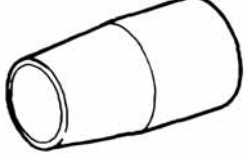
Serial	Part No	NSN	Name	Use	Illustration
4	LRT-57-007	5120-66-128-4334	Worm adjuster lock nut C-Spanner	Para 23 Para 25  Heavy Grade Repair	
5	LRT-57-006	5120-66-128-4335	Worm adjuster socket	Para 23 Para 25  Heavy Grade Repair	
6	LRT-57-019	5120-66-128-4330	Rotary valve ring expander	Para 24  Heavy Grade Repair	
7	LRT-57-020	5120-66-128-4329	Rotary valve ring compressor	Para 24  Heavy Grade Repair	
8	R01015	5120-66-128-4324	Input shaft seal saver	Para 25  Heavy Grade Repair	
9	LRT-57-017	5120-66-128-4336	Steering box torque setting tool	Para 25  Heavy Grade Repair	
10	LRT-57-021	5120-66-128-4333	Sector shaft seal saver	Para 25  Heavy Grade Repair	

UNCONTROLLED IF PRINTED

**MEDIUM GRADE REPAIR**

**STEERING**

**Steering Box**

14. **Removal.** Remove the steering box as follows:
  - a. Remove the filler cap from the steering fluid reservoir.
  - b. Disconnect the high pressure hose from the connector on the power steering pump and drain the fluid from the system via the disconnected hose into a suitable container and discard. Reinstall the filler cap and connect the high pressure hose to the steering pump.
  - c. Remove the two bolts securing the steering shaft cover to the inner guard and remove the cover.

- d. Using special tool LRT-57-018 (Table 2, Serial 1), disconnect the drop-arm ball joint.
- e. Disconnect the flexible hoses from the steering box housing (Figure 1), and then plug the disconnected hoses and connections, to prevent ingress of foreign matter.

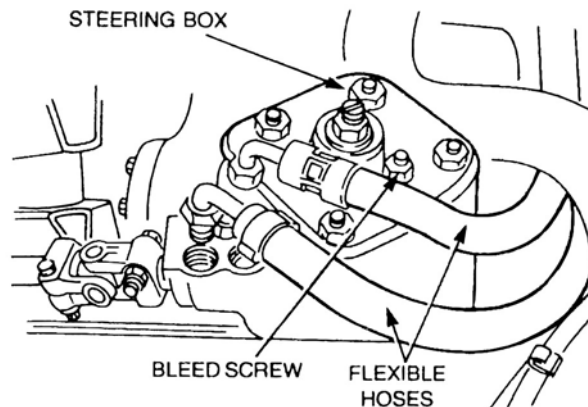

**Figure 1 Removal of the Flexible Hoses to the Steering Box**

- f. Chock the rear wheels, then using a suitable hydraulic jack, raise the front of the vehicle and support it on axle stands.
- g. Ensure the front wheels and the steering wheel are positioned in the straight ahead position, then match-mark the relationship of the steering column inner shaft to the top universal joint (Figure 2).

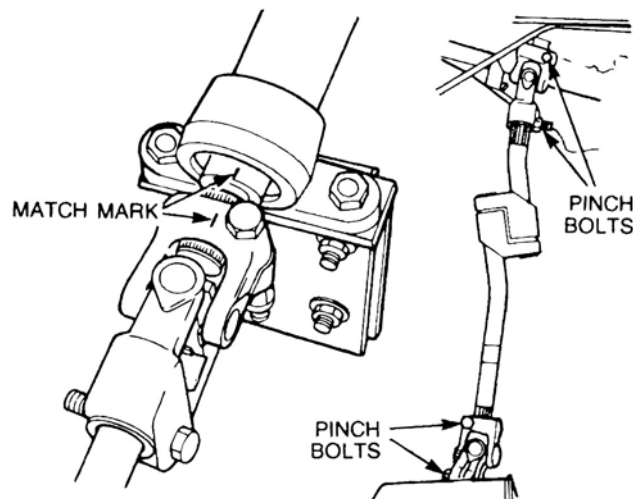

**Figure 2 Alignment of the Steering Column**

- h. Remove the pinch bolt and locknut securing the universal joint to the steering box worm shaft. Slacken the two pinch bolts securing the upper universal joint, then slide the collapsible shaft and lower universal joint off the steering box worm shaft. Discard the locknuts.
- i. Slacken the locknut securing the tie bar to the panhard rod mounting arm. Remove the two locknuts, washers and bolts securing the tie bar to the steering box (Figure 3), then swing the tie bar clear of the steering box. Discard the locknuts.

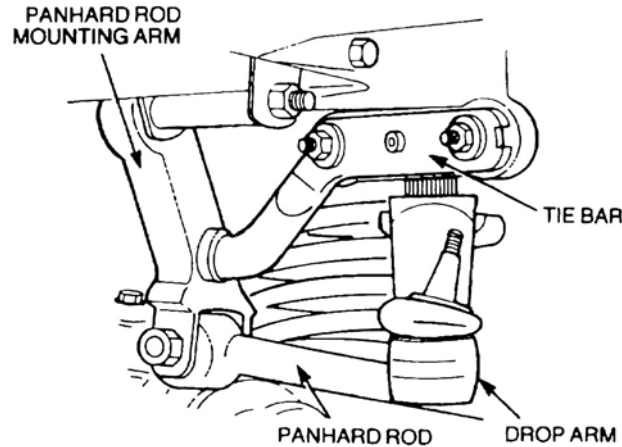

**Figure 3 Removal of the Tie Bar**

- j. Bend back the tabs on the locking plates, then remove the bolts securing the steering box to the chassis frame and remove the steering box. Discard the locking plates (Figure 4).

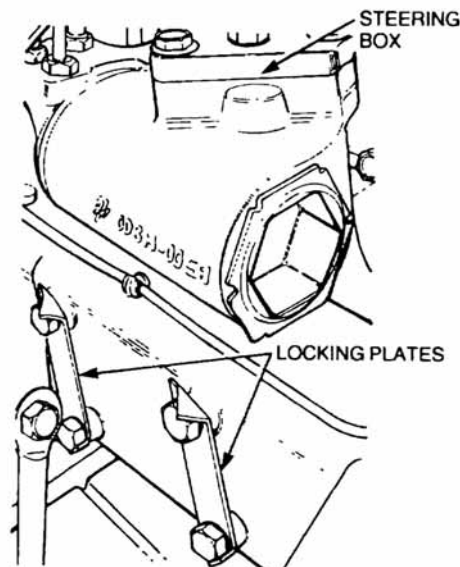

**Figure 4 Removal of the Steering Box**

15. **Installation.** Install the steering box as follows:
- a. Ensure the four mounting bolts and the new locking plates are positioned through the chassis, then install the steering box on the bolts. Fit the four flat washers and new lock-plates then tighten the bolts to 80 N.m. Bend the lock-plate tabs over the heads of the four bolts.
  - b. Check that the steering wheel is in the straight ahead position, then set the steering to the mid way lock-to-lock position.
  - c. Taking care not to turn the steering wheel, align the match-mark and install the top universal joint to the steering column inner shaft, then connect the lower universal joint on the steering box worm shaft and install the pinch bolts. Fit new locknuts to all the pinch bolts, then tighten them to 35 N.m.
  - d. Fit the steering shaft cover on the inner guard and secure it with the two bolts and washers.
  - e. Install the tie bar on the steering box, but do not tighten the two nuts and bolts.
  - f. Using a new locknut, secure the tie bar to the panhard rod mounting arm, do not tighten at this time. Slacken the two tie bar retaining bolts, then tighten them securely. Tighten the locknut securing the tie bar to the panhard rod mounting arm to 80 N.m.
  - g. Connect the drag link to the drop-arm and tighten the nut to 40 N.m, then insert a new split pin.

UNCONTROLLED IF PRINTED



- h. Remove the plugs from the steering box hoses and connections, then connect the flexible hoses to the steering box. Tighten the connections securely.
- i. Remove the filler cap and fill the reservoir with a recommended fluid to the full level marked on the dipstick. Install the filler cap.
- j. Using a suitable hydraulic jack, raise the front of the vehicle and remove the axle stands. Lower the vehicle and remove the chocks from the rear wheels.
- k. Bleed the power steering system in accordance with EMEI Vehicle G 093.

### Power Steering System Test

16. **Test Procedure.** Test the power steering system using the following procedure:

- a. Connect the components of the test equipment JD10 (Table 2, Serial 2) to the steering system as shown in Figure 5.

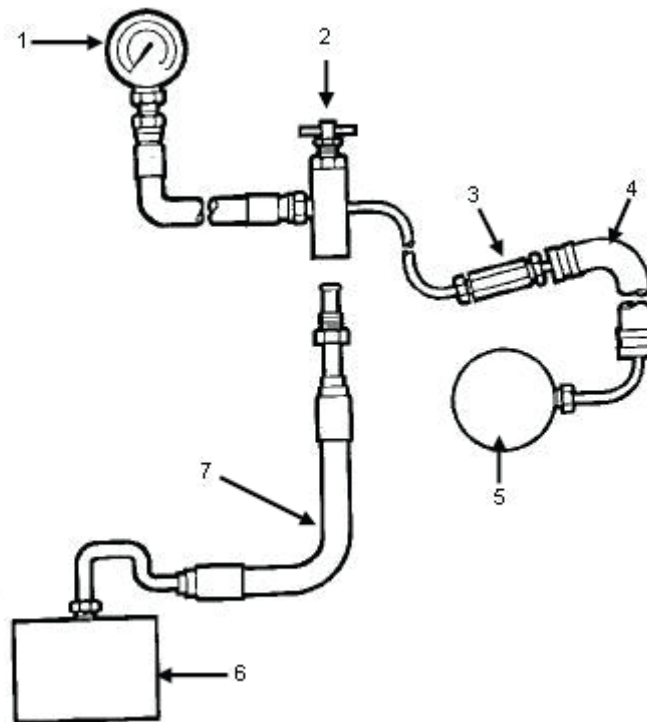

- |  |                    |
|--|--------------------|
| 1. Pressure gauge LRT-57-005           | 5. Steering pump   |
| 2. Test adaptor LRT-57-001             | 6. Steering box    |
| 3. Thread adaptor LRT-57-002           | 7. Hose LRT-57-030 |
| 4. Existing hose, steering box to pump |                    |

**Figure 5 Installation of the Test Equipment**

- b. Ensure that the system is free from leaks and check that the power steering reservoir fluid is at the correct level. Top it up if necessary.
- c. Open the tap in the adaptor, then start and run the engine and bleed the system (Ref EMEI Vehicle G 093), taking care not to overload the pressure gauge.



**Do not hold the steering in full-lock position for more than 30 seconds in any one minute period, otherwise overheating of the steering fluid and possible seal damage could result.**

- d. Run the engine at 1 000 rpm, turn the steering on hard full-lock and check for a reading of 5 860 to 6 550 kPa then repeat the test on the opposite lock.
- e. Run the engine at idle, then turn the steering on hard full-lock and check for a reading of 2 745 kPa. Repeat the test on the opposite lock.
- f. Release the steering wheel and with the engine idling, check for a pressure below 685 kPa.
- g. If the pressures registered are not to specification, close off the valve tap for no more than five seconds, and with the engine idling, check for a pressure of approximately 2 745 kPa. If the pressure fails to reach specification, repair or replace the pressure relief valve and retest the system.
- h. If the pressures shown are to specification when the valve tap is closed off, the fault is in the rotary valve on the steering box input shaft. Repair or replace the rotary valve (input shaft) as necessary.

17. Table 3 is a fault finding table for the power steering.

**Table 3 Power Steering Fault Finding**

Serial	Symptom	Probable Cause	Action
1	Oil leaking at output shaft of steering box	Clogged oil filter in reservoir (high back pressure) Restricted oil return line	Replace reservoir Check and rectify as necessary
2	Oil leaking between the reservoir and pump	Loose at connections or adapter Damaged pressure or return lines	Check and rectify as necessary Replace as necessary
3	Oil forced from the oil reservoir	Clogged oil filter in reservoir Air in system	Replace reservoir Bleed the system and check for air leaks
4	Engine oil in the power steering reservoir	Faulty oil pump shaft seal	Repair power steering pump
5	No power steering on a cold start	Vanes in power steering pump not extending	Increase engine speed to extend vanes and start pump action. Usually a temporary or infrequent occurrence, pump repair or replacement not required
6	Hard steering	Faulty power steering pump	Repair or replace pump

UNCONTROLLED IF PRINTED

## BODY

### Rollover Protection

#### WARNING

The rollover protection assembly is to be replaced if the vehicle has been involved in a rollover accident.

The rollover protection assembly is to be replaced where distortion has occurred to the roll over structure or capping rails.

The rollover protection assembly is to be replaced if any welds are cracked or have failed.

The rollover protection is NOT to be modified or repaired by drilling, grinding or welding the structure. The ROPS is to be repaired by replacement as detailed in EMEI Vehicle G 098-1.

#### NOTE

Loose/damaged hardware used for mounting the camouflage net carrier are authorised to be repaired in accordance with the procedure detailed in EMEI Vehicle G 093.

### Cargo Tray Bins

18. **Removal.** Remove the cargo tray bins as follows:
- Drill out all retaining rivets from the cargo tray bins. Securing rivets are located in line with the vehicle coaming rail, along the top of the cargo tray bins adjacent to the bulkhead and along the floor assembly of the cargo tray bins.
  - With a sharp blade or Stanley knife cut along the sealant bead between the cargo tray bins and the vehicle coaming rail.
  - Remove the cargo tray bins and clean off any remaining sealant left over from sub Para b above.
  - Clean off the sealant along the vehicle coaming rail in preparation to reinstalling the cargo tray bins.
19. **Installation.** Install the cargo tray bins as follows:
- Apply sealant (Sikaflex – 529 Sprayable Sealant or equivalent) to the left and right cargo tray side surface above the rivet hole line. The purpose of the sealer is to provide a water cap to the rivets.

#### NOTE

- Ensure that when installing the securing rivets in the floor of the cargo tray bins that they also retain the top flanges of the rear seat mounting reinforcements.
- Install the cargo tray bins into the cargo tray and install the securing rivets. Securing rivets are located in line with the vehicle coaming rail, along the top of the cargo tray bins adjacent to the bulkhead and along the floor assembly of the cargo tray bins.
  - Apply sealant (Sikaflex – 529 Sprayable Sealant or equivalent) to the upper most mating surface between the cargo tray bins and the vehicle coaming rail. Apply this sealer for the entire length of the joint.

## HEAVY GRADE REPAIR

## STEERING

### Power Steering Pump

20. **Disassembly.** Disassemble the power steering pump (Figure 6) as follows:

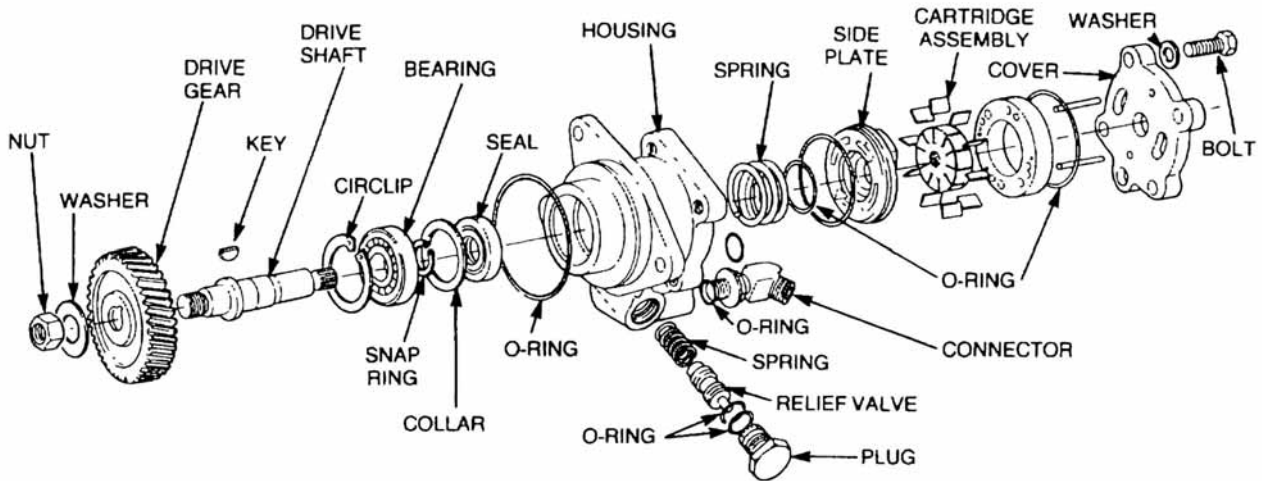

**Figure 6 Power Steering Pump Exploded View**

- a. Remove the power steering pump in accordance with EMEI Vehicle G 093.
- b. Secure the pump in a vice with the side cover facing up.
- c. Remove the plug from the pump housing and withdraw the relief valve and spring.
- d. Remove the four bolts and washers securing the cover (Figure 7) to the power steering pump. Remove the cover.

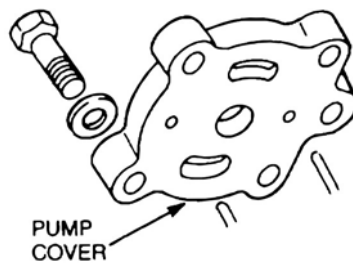

**Figure 7 Steering Pump Cover**

- e. Remove the power steering pump from the vice and by gently shaking the pump, remove the cartridge and coil spring (Figure 8).

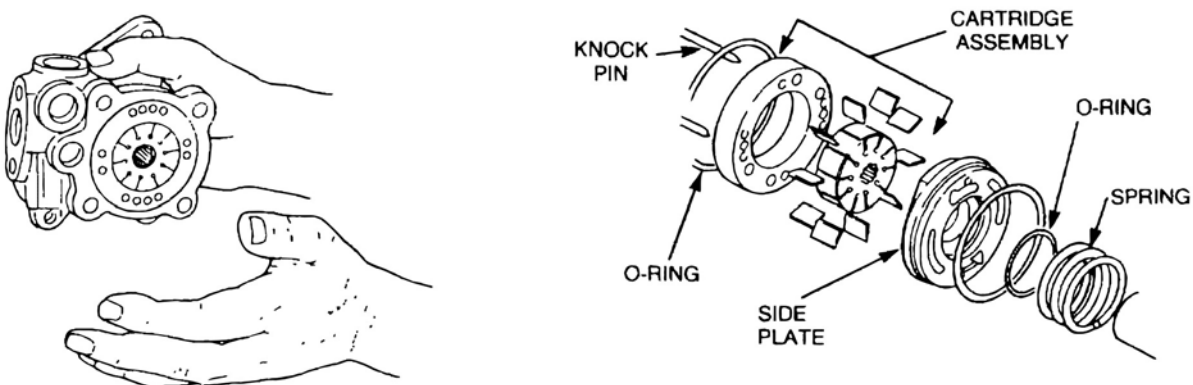

**Figure 8 Cartridge and Coil Spring**

- f. Remove the nut and washer securing the oil pump drive gear to the shaft, and then remove the drive gear from the shaft (Figure 9).

UNCONTROLLED IF PRINTED

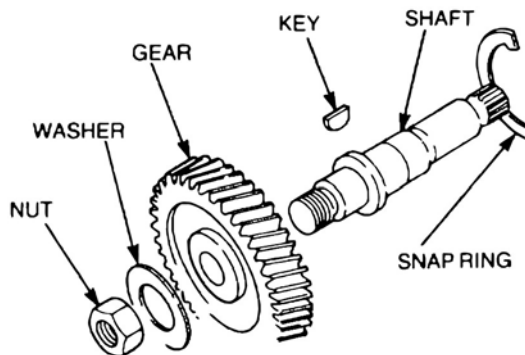

**Figure 9 Removal of the Drive Gear**

- g.** Using pointed-nose pliers, remove the snap-ring, then remove the pump shaft from the housing by lightly tapping the shaft with a soft hammer (Figure 10).

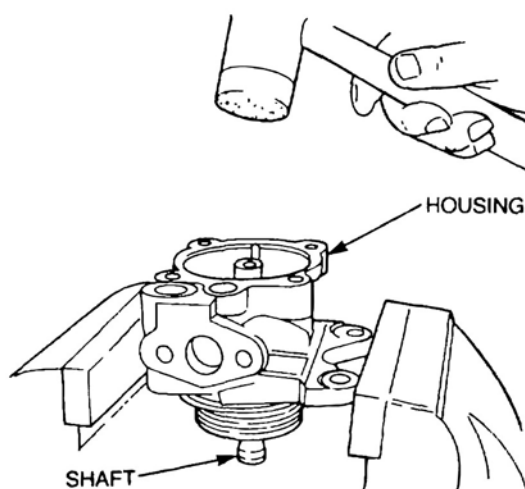

**Figure 10 Removal of the Pump Shaft**

- h.** Using a suitable lever, pry the oil seal from the pump housing, then remove the snap-ring retaining the bearing (Figure 11). Remove the bearing housing.

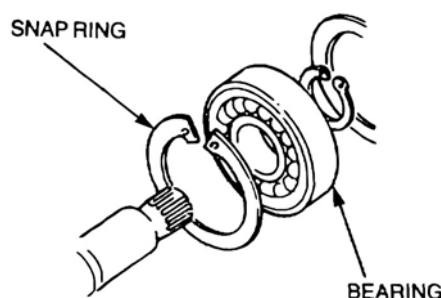

**Figure 11 Removal of the Bearing**

- 21. Cleaning and Inspection.** Clean and inspect the power steering pump as follows:
  - a.** Thoroughly clean all the parts with a solvent which is compatible with the system fluid, then dry all the parts with filtered, dry, compressed air. Keep all the parts clean during inspection and reassembly, otherwise damage of close tolerance parts may result.
  - b.** Inspect the wearing surfaces of the body, cam-ring and rotor for scoring or excessive wear. Remove light score marks by lapping, and replace heavily scored or badly worn parts.
  - c.** Inspect the vanes for burrs, wear or excessive play in the rotor slots. Replace badly worn or scored parts.

UNCONTROLLED IF PRINTED

- d. Inspect the oil seal wearing surface on the shaft for scoring or wear. If marks are present and cannot be removed by light polishing, replace the shaft.
- e. Check for free movement of the relief valve in the cover bore. Remove any burrs with light polishing, taking care not to round off the sharp edges of the lands. Do not attempt to rework the valve bore. Replace the cover if the bore is damaged.
- f. Check that the spool when inserted in its housing does not stick by manually operating the spool control valve.
- g. Measure the outside of the flow control valve spool and the inside diameter of the spool hole, if the measurement exceeds 0.030 mm, replace the control valve spool.

**22. Reassembly.** Reassemble the power steering pump as follows:

- a. Apply a suitable lubricant to all parts prior to reassembly. A small amount of petroleum jelly can be used to hold the O rings in position during reassembly.
- b. Secure the pump body in a vice and using a suitable mandrel, tap the oil seal into position in the pump body. Lubricate the seal lip with petroleum jelly.
- c. Position the Woodruff key in the key-way on the drive shaft, then install the drive gear on the drive shaft and secure it with the washer and nut. Tighten the nut to 73 to 84 N.m.
- d. Support the bearing and press the shaft into the bearing.
- e. Install the snap-ring in the groove on the bearing, then slide the shaft and collar into the body until the bearing is correctly seated. A light tap with a soft hammer may be necessary to correctly seat the bearing.
- f. Install the inner and outer O rings to the side plate, then install the spring and the side plate into the pump body.

**NOTE**

Due to the possibility of damage to the machined cartridge parts during handling and shipping, all sharp edges should be oil-stoned prior to reassembly.

- g. Assemble the cartridge assembly, ensuring that the R-shaped area of the vanes touch the surface of the cam profile.
- h. Install the cartridge into the pump body, ensuring that the reference holes in the side plate and cam-ring are aligned in the same direction.
- i. Fit the O ring into the pump body, then install the locating pins in the side cover and position the cover on the pump, install the bolts and tighten them to 30 to 40 N.m.
- j. Insert the flow control spring, valve and O rings into the bore in the body, and then install the O ring on the plug. Install the plug and tighten it to 73 to 84 N.m.
- k. Carefully fit the discharge connector and tighten it to 68 to 78 N.m.
- l. Install the power steering pump on the engine in accordance with EMEI Vehicle G 093.

**Steering Box**

**23. Disassembly.** Disassemble the steering box as follows:

- a. Centralise the sector shaft with the input shaft worm, then match-mark the drop-arm to the sector shaft, then remove the drop-arm using special tool LRT-57-012 (Table 2, Serial 3).
- b. At the rack and piston bore in the housing, rotate the retaining ring (if necessary) until one end is approximately 12 mm from the extractor hole, then insert a suitable pointed drift into the extractor hole to unseat the retaining ring from the groove (Figure 12). Remove the retaining ring, then rotate the steering input shaft toward the right-hand lock, until the piston pushes the end cover out from the rack and piston bore.

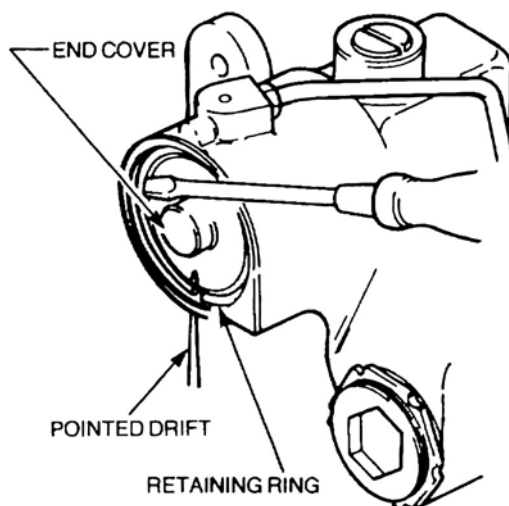

**Figure 12 Rack and Piston Retaining Ring Removal**

- c. Remove the grub screw (Figure 13) from the rack pad adjuster, then with a suitable screwdriver remove the rack pad adjuster. Remove and discard the sealing ring and the nylon rack pad.

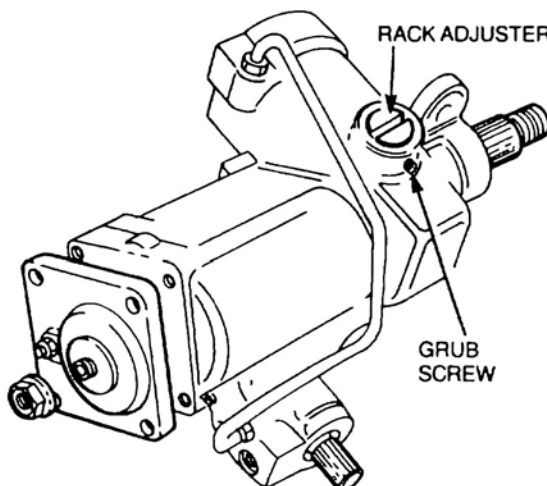

**Figure 13 Rack Pad Adjuster Removal**

- d. Remove the sector shaft locknut from the top of the steering box, then remove the four bolts and washers securing the sector shaft cover to the top of the steering box. With the aid of a suitable screwdriver, screw the sector shaft adjuster in until the cover can be removed. Remove the cover, then slide the sector shaft out from the steering box. Discard the O ring.
- e. Remove the piston from the rack and piston bore by threading a suitable bolt into the tapped hole in the piston, and pulling the piston from the bore.
- f. Using a C-spanner, special tool LRT-57-007 (Table 2, Serial 4), remove the locknut from the worm adjuster, then remove the worm adjuster using special tool LRT-57-006 (Table 2, Serial 5).

**NOTE**

To remove the inner bearing cup and shims, jar the steering box housing on the work bench or use a suitable extractor, e.g. a bronze drift and a hammer.

- g. Using a soft-headed hammer, tap the splined end of the input shaft to free the bearing from the housing. Remove the outer bearing cup and cage, then withdraw the input (worm) shaft assembly together with the inner bearing cage, from the housing (Figure 14). Remove the inner bearing cup, together with the shims and retain the shims.

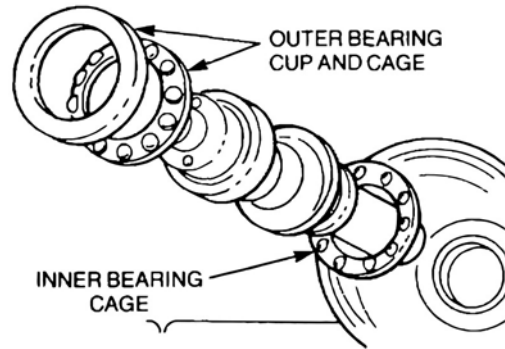
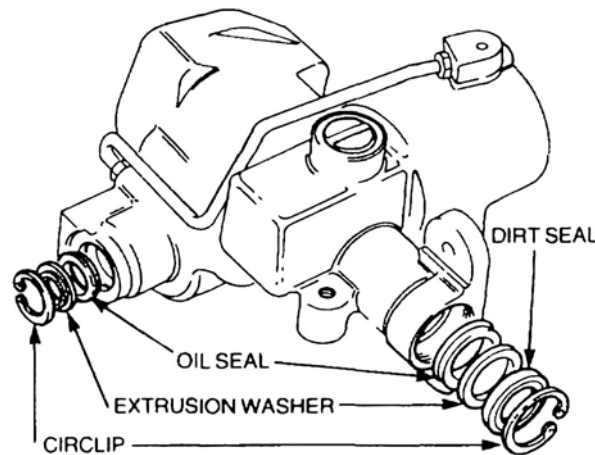

**Figure 14 Input Shaft and Bearings Removal**

- h.** Remove the circlips and seals from the sector shaft bore and the input shaft bore (Figure 15).

**NOTE**

Do not remove the sector shaft bushes from the shaft bore unless replacement is necessary.



**Figure 15 Removal of the Sector and Input Shaft Seals**

- 24. Cleaning and Inspection.** Clean and inspect the steering box as follows:

- a.** Clean all parts with a suitable cleaning agent, ensuring that all gasket material is removed, then allow them to dry.
- b.** Remove and discard the plastic ring and rubber seal from the piston, then check the piston for scoring, wear or damage and check the teeth on the rack for wear or damage. Replace the rack and piston assembly if excessive wear or damage is evident.

**NOTE**

Ensure that the tubing is a neat fit in the sector shaft bore and butts squarely against the bush.

- c.** Check the sector shaft bushes for roundness or damage and replace them as required. If replacement is necessary, use a suitable piece of tubing and a hammer (or press) to drive the bushes from the housing.
- d.** Inspect the piston bore for scoring, gouging or wear and replace the housing as necessary.
- e.** Inspect the transfer pipe for signs of cracking and replace as necessary.
- f.** Check all threaded holes, ports and bores for damaged threads. If necessary, use suitable taps to clean or dress threads, or replace the housing if thread damage is severe.



- g.** Inspect the sector shaft for uneven wear on the gear teeth, worn or badly damaged adjuster screw thread, obvious side play on the rollers and excessive wear on the bush running area of the shaft. Replace the sector shaft if any of these faults are evident.
- h.** Check the bush in the sector shaft cover for wear and replace the cover as an assembly if wear is evident.
- i.** Check the valve rings on the valve and worm assembly for cuts, scratches, grooves or other damage and replace as necessary. If replacement is required, install the new rings using the ring expander, special tool LRT-57-019 (Table 2, Serial 6). If necessary, warm the valve rings and the expander with hot water to assist with installation, then install the ring compressor, special tool LRT-57-020 (Table 2, Serial 7), to cool the rings.
- j.** Check that the bearing running surfaces and the worm on the valve and worm assembly are smooth and without any sign of pitting, galling, indentations or uneven wear. Check for wear in the torsion bar assembly pins; no free movement should exist between the input shaft and the worm. Replace the valve and worm assembly if any wear or damage is evident.
- k.** Inspect the rack thrust pad adjuster and the adjuster grub screw for wear or damage and replace them as necessary. Replace the nylon thrust pad.
- l.** Inspect the rack and piston assembly for worn or damaged rack teeth, damaged thrust pad bearing surface, damage to the outer diameter of the piston and scoring or damage to the seal and ring groove of the piston. Replace the rack and piston assembly if any of these faults is evident.

**25. Reassembly.** Reassemble the steering box as follows:

- a.** Install a new oil seal, with the open side toward the housing, into the input shaft bore. Ensure that the seal flange butts against the shoulder in the bore, then install the extrusion washer and a new circlip (Figure 16).

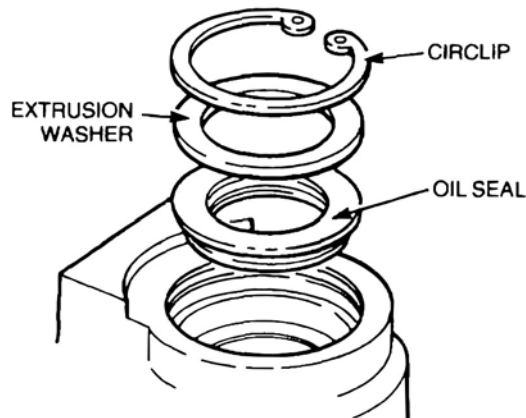

**Figure 16 Input Shaft Oil Seal Installation**

**NOTE**

Ensure that the tubing is a neat fit in the sector shaft bore and butts squarely against the bush.

- b.** If removed, install new bushes into the sector shaft bore in the housing. Align and start each bush into the housing, then with the aid of a press and a suitable piece of tubing, press the bushes into position.
- c.** Install a new oil seal, with the lip side in, into the sector shaft bore, then install the extrusion washer and a new dirt seal with the lip side out. Install a new circlip to retain the seals in position (Figure 17).

UNCONTROLLED IF PRINTED

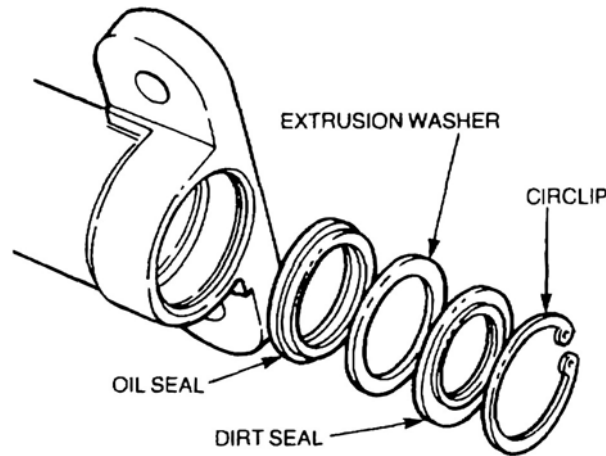

Figure 17 Sector Shaft Oil Seals Installation

NOTE

If the original shims are not available, install shims with a nominal thickness of 0.76 mm.

- d. Lubricate the new input shaft bearings with petroleum jelly, then install the inner bearing cup together with the original shims, or shims of equivalent thickness, into the input shaft bore of the housing.
- e. Position the inner bearing cage on the input shaft, then install a seal saver, special tool R01015 (Table 2, Serial 8) over the splined end of the input shaft. Smear the sealing lip of the input shaft seal with petroleum jelly, then install the input shaft into the housing and position the outer bearing cage and cup on the input shaft.
- f. Install a new sealing ring on the worm adjuster and loosely screw the adjuster into the housing, then install the locknut (Figure 18), but do not tighten it. Screw the worm adjuster in until the input shaft end-float is almost eliminated. Install the torque setting tool LRT-57-017 (Table 2, Serial 9) onto the input shaft, then coil a length of cord several times around the tool and attach a suitable spring scale to one end of the cord. Pull on the scale with a slow and steady pull until the input shaft rotates. Record the load indicated on the scale required to keep the input shaft turning slowly and evenly.

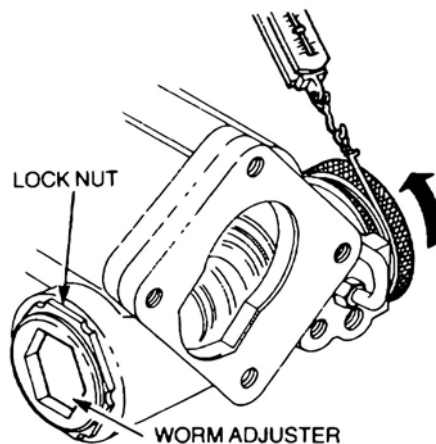

Figure 18 Input Shaft Adjustment

- g. Using the worm adjusting socket, special tool LRT-57-006 (Table 2, Serial 5), screw in the worm adjuster to increase the previously recorded rolling resistance by 1.8 to 2.2 kg, on a setting tool radius of 31.7 mm, to settle the bearings. Back off the worm adjuster until the previously recorded rolling resistance is increased by 0.9 to 1.3 kg, then tighten the locknut using a C-spanner, special tool LRT-57-007 (Table 2, Serial 4), and check that the rolling resistance has not altered.

UNCONTROLLED IF PRINTED

- h. Install a new rubber seal into the groove on the piston, ensure that the seal is not twisted, then smear the seal with petroleum jelly. Heat the nylon ring with hot water, then install the ring alongside the seal in the piston groove and allow the ring to cool.
- i. Thread a suitable bolt into the tapped hole in the piston, then with the aid of the bolt, insert the piston and rack assembly into the bore in the housing until the crown of the piston is 63.5 mm from the outer end of the bore.
- j. Install the seal saver, special tool LRT-57-021 (Table 2, Serial 10), onto the threaded end of the sector shaft, then liberally coat the sector shaft with clean power steering fluid. Smear the seal lips on both the oil seal and dirt seal, in the sector shaft bore, with petroleum jelly and liberally coat both the worm and the rack with clean power steering fluid. Start the sector shaft into the housing and align the pitch of the centre tooth of the rack with the centre tooth of the sector shaft gear (Figure 19). Insert the sector shaft while simultaneously rotating the input shaft about a small arc to engage the sector shaft roller with the worm.

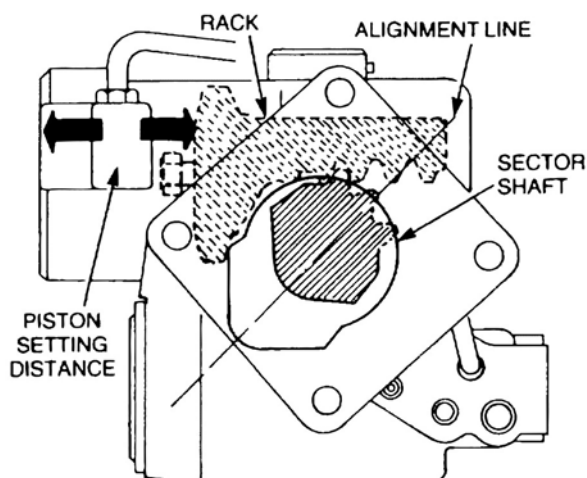

Figure 19 Sector Shaft Installation

- k. Install a new sealing ring on the rack adjuster and install the adjuster (Figure 13), together with a new nylon thrust pad, into the housing. Screw in the adjuster until the thrust pad makes contact with the rack, then back the adjuster out half a turn. Screw in the grub screw until it contacts the rack adjuster, but do not tighten it.

**NOTE**

Before securing the cover to the housing, rotate the input shaft to ensure that the sector shaft roller moves freely on the input shaft worm.

- l. Position a new O ring in the sector shaft cover, then screw the cover fully onto the sector shaft adjusting screw. Align the bolt holes in the cover with those in the housing, then tap the cover with a soft-headed hammer to joint the cover fully with the housing. If necessary, back off the sector shaft adjusting screw to allow the cover to joint fully with the housing.
- m. Install the sector shaft cover retaining bolts and tighten the bolts to between 22 and 27 N.m.
- n. Install a new sealing ring on the piston bore cover and smear the sealing ring with petroleum jelly. Remove the bolt from the piston, then install the cover into the piston bore. Press the cover into the bore sufficiently to clear the retaining ring groove, then install a new retaining ring, ensuring that one end of the ring is approximately 12 mm from the extractor hole.
- o. Centralize the sector shaft on the worm by halving the number of turns of the input shaft when turned from lock to lock. Slacken the sector shaft adjusting screw to obtain backlash between the input shaft and the sector shaft, then screw the adjusting screw in until the backlash is just eliminated. Using the spring scale and the torque setting tool LRT-57-017 (Table 2, Serial 9) (previously installed on the input shaft), measure and record the maximum rolling resistance of the input shaft (Figure 20). Loosely install a new locknut onto the sector shaft adjusting screw while holding the screw stationary, then

screw the adjusting screw in until the recorded rolling resistance has been increased by 0.9 to 1.3 kg when the locknut is tightened. Readjust as necessary.

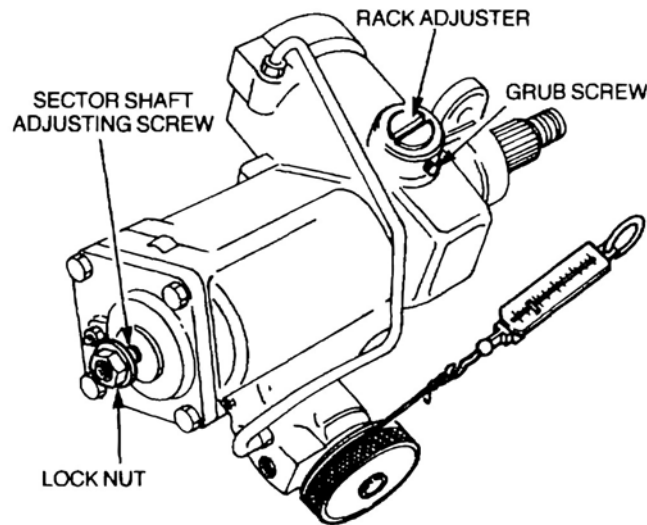

**Figure 20 Sector Shaft Adjustment**

- p. With the spring scale and torque setting tool on the input shaft, adjust the rack adjuster until the rolling resistance is 0.9 to 1.3 kg above the final rolling resistance setting of the sector shaft. Ensure that the rolling resistance does not exceed 7.25 kg, then tighten the grub screw to lock the rack adjuster in position.

**NOTE**

An adjustment of 0.07 mm to the thickness of the shims will move the position of the highest reading by approximately a quarter of a turn of the input shaft.

- q. Using the torque setting tool LRT-57-017 (Table 2, Serial 9) and the spring scale, measure the rolling resistance of the worm and roller. Turn the input shaft to the left-hand full lock position and attach the spring scale to the torque setting tool. Place a chalk mark on the torque setting tool (for reference purposes), then pull the spring scale with a slow and steady pull. The highest reading on the spring scale should occur when the sector shaft roller travels across the centre of the worm (approximately one and a half turns from the left full lock position). If the highest reading occurs before reaching the centre of travel, reduce the thickness of the shims located between the input shaft inner bearing and the housing. If the highest reading occurs after the centre of travel, increase the thickness of the shims.
- r. Once the correct shim and adjustment has been made, reassemble the steering box and repeat the adjustment procedures (sub-para e, f, g, j, l, m, o, p and q).
- s. Centralize the sector shaft with the input shaft worm, then position the drop-arm on the sector shaft, ensuring that the match-marks are aligned. Install the retaining nut, together with a new tab washer, and tighten the nut to 169 N.m.
- t. Install the steering box (Para 15) and bleed the power steering system in accordance with EMEI Vehicle G 093.

- 26. The steering specifications are detailed in Table 4.

**Table 4 Steering Specifications**

Serial	Item	Specification
1	Power steering pump flow control valve spool-to-spool hole clearance	0.030 mm
2	Power steering pump gear to drive shaft tightening torque	73 to 84 N.m
3	Power steering pump side cover to pump body tightening torque	30 to 40 N.m

UNCONTROLLED IF PRINTED

**Table 4 Steering Specifications (Continued)**

<b>Serial</b>	<b>Item</b>	<b>Specification</b>
4	Power steering pump control valve plug tightening torque	73 to 84 N.m
5	Power steering pump discharge connector tightening torque	68 to 78 N.m
6	Input shaft shims nominal thickness	0.76 mm
7	Input shaft bearing rolling resistance	Add 1.8 to 2.2 kg to initial resistance obtained (Para 25), then back off the worm adjuster until the initial resistance is increased by only 0.9 to 1.3 kg
8	Piston and rack assembly installation setting	Crown of piston 63.5 mm from outer end of bore
9	Sector shaft cover bolts tightening torque	22 to 27 N.m
10	Piston bore cover retaining ring	End of ring to be 12 mm from extractor hole
11	Sector shaft resistance adjustment	Input shaft rolling resistance to be increased by 0.9 to 1.3 kg with sector shaft adjuster locknut tightened
12	Rack resistance adjustment	Input shaft rolling resistance to be increased by 0.9 to 1.3 kg above the resistance setting for the sector shaft, but must not exceed 7.25 kg
13	Sector shaft-to-input shaft resistance position	Alteration to the input shaft bearing shim thickness of 0.07 mm alters the position of the highest resistance by a quarter of a turn of the input shaft
14	Drop-arm nut tightening torque	169 N.m
15	Steering box mounting bolts and nuts tightening torque	80 N.m
16	Steering column universal joint pinch bolts tightening torque	35 N.m
17	Tie bar to Panhard rod mounting tightening torque	80 N.m
18	Drag link to drop arm retaining nut tightening torque	40 N.m
<b>Power steering test pressures</b>		
19	Full lock with engine at 1000 rpm	5 860 to 6 550 kPa
20	Full lock with engine at idle	2 745 kPa
21	Steering wheel released with engine at idle	685 kPa
22	Valve tap closed with engine at idle	2 745 kPa

UNCONTROLLED IF PRINTED

**END**

Distribution List: **VEH G 16.7 – Code 3** (Maint Level)  
(Sponsor: CGSV SPO, Light B Vehicles)  
(Authority: DAC LVSP0 085/07 021/08)