

VEHICLE STANDARD (AUSTRALIAN DESIGN RULE **46/00 - HEADLAMPS**) 2006
VOLUME 2

APPENDIX E

UN-ECE REGULATION NO. 31/02

**UNIFORM PROVISIONS CONCERNING THE APPROVAL OF HALOGEN
SEALED BEAM UNIT (HSB) MOTOR VEHICLE HEADLAMPS EMITTING AN
ASSYMERICAL PASSING BEAM OR A DRIVING BEAM OR BOTH**

**UNIFORM PROVISIONS CONCERNING THE APPROVAL OF HALOGEN
SEALED-BEAM UNIT (HSB UNIT) MOTOR VEHICLE HEADLAMPS EMITTING
AN ASYMMETRICAL PASSING BEAM OR A DRIVING BEAM OR BOTH**

CONTENTS

REGULATION

1. Scope
2. Definitions
3. Application for approval
4. Markings
5. Approval
6. General specifications
7. Rated and test values
8. Illumination
9. Colour
10. Gauging of discomfort
11. Conformity of production
12. Penalties for non-conformity of production
13. Modification and extension of approval of a type of halogen sealed-beam headlamp unit (HSB unit)
14. Production definitely discontinued
15. Transitional provisions
16. Names and addresses of technical services responsible for conducting approval tests and of administrative departments

ANNEXES

- Annex 1 - Communication concerning the approval or extension or refusal or withdrawal of approval or production definitely discontinued of a type of halogen sealed-beam headlamp unit (HSB unit) pursuant to Regulation No. 31
- Annex 2 - Example of arrangements of approval marks
- Annex 3 - Electrical connections of HSB units
- Annex 4 - Measuring screen
- Annex 5 - Minimum requirements for conformity of production control procedures
- Annex 6 - Tests for stability of photometric performance of headlamps in operation
- Annex 7 - Requirements for lamps incorporating lenses of plastic material - testing of lens or material samples and of complete lamps
- Appendix 1 - Chronological order of approval tests
- Appendix 2 - Method of measurement of the diffusion and transmission of light
- Appendix 3 - Spray testing method
- Appendix 4 - Adhesive tape adherence test
- Annex 8 - Minimum requirements for sampling by an inspector
-

Regulation No. 31

UNIFORM PROVISIONS CONCERNING THE APPROVAL OF HALOGEN SEALED-BEAM UNIT (HSB UNIT) MOTOR VEHICLE HEADLAMPS EMITTING AN ASYMMETRICAL

PASSING BEAM OR A DRIVING BEAM OR BOTH

1. SCOPE ^{1/}

This Regulation applies to motor vehicle headlamps which may incorporate lenses of glass or plastic material.

2. DEFINITIONS

For the purpose of this Regulation,

- 2.1. "Halogen sealed-beam headlamp unit" (hereinafter termed "HSB unit") means a headlamp whose components, including a reflector of glass, metal or other material, an optical system and one or more halogen light sources, form an integral whole which is indivisibly joined and cannot be dismantled without rendering the unit completely unusable. Such units are:
 - 2.1.1. of "category 1", when they emit only a driving beam;
 - 2.1.2. of "category 21", when they emit only a passing beam;
 - 2.1.3. of "category 22", when they emit, at the user's choice, either a driving beam or a passing beam;
- 2.2. "Lens" means the outermost component of the headlamp (unit) which transmits light through the illuminating surface;
- 2.3. "Coating" means any product or products applied in one or more layers to the outer face of a lens;
- 2.4. "HSB units of different types" means units which differ in such essential respects as:
 - 2.4.1. the trade name or mark;
 - 2.4.2. the characteristics of the optical system;
 - 2.4.3. the inclusion or elimination of components capable of altering the optical effects by reflection, refraction, absorption and/or deformation during operation; the fitting or elimination of filters intended solely to change the colour of the beam but not its light distribution does not constitute a change of type;
 - 2.4.4. the rated voltage;
 - 2.4.5. the shape of the filament or filaments;
 - 2.4.6. the kind of beam produced (passing beam, driving beam or both);
 - 2.4.7. the materials constituting the lens and coating, if any.

^{1/} Nothing in this Regulation shall prevent a Party to the Agreement applying this Regulation from prohibiting the combination of an HSB unit incorporating a lens of plastic material approved under this Regulation with a mechanical headlamp-cleaning device (with wipers).

3. APPLICATION FOR APPROVAL

- 3.1. The application for approval shall be submitted by the owner of the trade name or mark or by his duly accredited representative. It shall specify:
 - 3.1.1. whether the HSB unit is intended to provide both a passing beam and a driving beam or only one of these beams;
 - 3.1.2. where the HSB unit is intended to provide a passing beam, whether it is designed for both right-hand and left-hand traffic or for right-hand or left-hand traffic only.
- 3.2. Every application for approval shall be accompanied by:
 - 3.2.1. drawings in triplicate, sufficiently detailed to permit identification of the type and giving a front view of the HSB unit (with, if applicable, details of the lens moulding) and a cross-section; also the filament(s) and shield(s) shall be shown on the drawings at a scale of 2:1 both in front view and in side view; the drawing must show the position intended for the approval number and the additional symbols in relation to the circle of the approval mark;
 - 3.2.2. a brief technical description;
 - 3.2.3. samples as follows:
 - 3.2.3.1. for approval of an HSB unit emitting uncoloured light: five samples,
 - 3.2.3.2. for approval of an HSB unit emitting coloured light: two coloured-light samples and five uncoloured-light samples of the same type, differing from the type submitted, only in that the lens or filter is not coloured,
 - 3.2.3.3. in the case of HSB units which emit coloured light, which differ from uncoloured-light units only in the colour of light emitted and which have already satisfied the requirements of paragraphs 6., 7. and 8. below, it will be sufficient to submit only one sample of a coloured-light unit to undergo the tests described in paragraph 9. below.
 - 3.2.4. For the test of plastic material of which the lenses are made:
 - 3.2.4.1. thirteen lenses.
 - 3.2.4.1.1. Six of these lenses may be replaced by six samples of material at least 60 x 80 mm in size, having a flat or convex outer surface and a substantially flat area (radius of curvature not less than 300 mm) in the middle measuring at least 15 x 15 mm.
 - 3.2.4.1.2. Every such lens or sample of material shall be produced by the method to be used in mass production,
 - 3.2.4.2. a reflector to which the lenses can be fitted in accordance with the manufacturer's instructions.
- 3.3. The characteristics of the materials making up the lenses and coatings, if any, should be accompanied by the test report on these materials and coatings if they have already been tested.
- 3.4. The competent authority shall verify the existence of satisfactory arrangements for ensuring effective control of the conformity of production before type approval is granted.

4. MARKINGS^{2/}

- 4.1. HSB units submitted for approval shall bear the trade name or mark of the applicant.
- 4.2. They shall comprise, on the lens, a space of sufficient size to accommodate the approval mark and the additional symbols provided for in paragraph 5. below; the space shall be shown in the drawings referred to in paragraph 3.2.1. above.
- 4.3. They shall bear, either on the lens or on the body, the rated voltage and rated wattage of the driving-beam filament, followed by the rated wattage of the passing-beam filament, where applicable.

5. APPROVAL

5.1. General

- 5.1.1. If all the HSB unit type samples submitted in pursuance of paragraph 3. above meet the requirements of this Regulation, approval shall be granted.
 - 5.1.2. Where grouped, combined or reciprocally incorporated lamps satisfy the requirements of more than one Regulation, a single international approval mark may be affixed provided that each of the grouped, combined or reciprocally incorporated lamps satisfies the provisions applicable to it.
 - 5.1.3. An approval number shall be assigned to each type approved. Its first two digits (at present 02) shall indicate the series of amendments incorporating the most recent major technical amendments made to the Regulation at the time of issue of the approval. The same Contracting Party may not assign the same number to another type of HSB unit covered by this Regulation except in the case of an extension of the approval to a device differing only in the colour of the light emitted.
 - 5.1.4. Notice of approval or of extension or refusal or withdrawal of approval or production definitely discontinued of a type of optical unit pursuant to this Regulation shall be communicated to the Parties to the 1958 Agreement applying this Regulation, by means of a form conforming to the model in annex 1 to this Regulation.
 - 5.1.5. In addition to the mark prescribed in paragraph 4.1., an approval mark as described in paragraphs 5.2. and 5.3. below shall be affixed in the spaces referred to in paragraph 4.2. above to every headlamp conforming to a type of HSB unit approved under this Regulation.
- 5.2. Composition of the approval mark
- The approval mark shall consist of:
- 5.2.1. an international approval marking, comprising
 - 5.2.1.1. a circle surrounding the letter "E" followed by the distinguishing number of the country which has granted approval;^{3/}

^{2/} In the case of units designed to meet the requirements of traffic moving on one side of the road only (either right or left), it is further recommended that the area which can be occulted to prevent discomfort to users in a country where traffic moves on the side of the road opposite to that for which the unit was designed should be outlined indelibly on the lens. This marking is not necessary, however, where the area is clearly apparent from the design.

- 5.2.1.2. the approval number prescribed in paragraph 5.1.3. above;
- 5.2.2. the following additional symbol (or symbols):
 - 5.2.2.1. on HSB optical units meeting left-hand traffic requirements only, a horizontal arrow, pointing to the right of an observer, facing the HSB optical unit, i.e., to the side of the road on which the traffic moves;
 - 5.2.2.2. on HSB optical units meeting the requirements of this Regulation in respect of the passing beam only, the letters "HSC";
 - 5.2.2.3. on HSB optical units meeting the requirements of this Regulation in respect of the driving beam only, the letters "HSR";
 - 5.2.2.4. on HSB optical units meeting the requirements of this Regulation in respect of both the passing beam and the driving beam, the the letters "HSCR";
 - 5.2.2.5. on HSB optical units meeting the requirements of this Regulation in respect of the driving beam, an indication of the maximum luminous intensity expressed by a reference mark, as defined in paragraph 8.3.2.1.2. below, placed near the circle surrounding the letter "E";
 - 5.2.2.6. on HSB units incorporating a lens of plastic material, the group of letters "PL" near the symbols prescribed in paragraphs 5.2.2.3. to 5.2.2.5. above;
 - 5.2.2.7. the two digits of the approval number (at present 02) which indicate the series of amendments incorporating the most recent major technical amendments made to the Regulation at the time of issue of the approval and, if necessary, the required arrow may be marked close to the above additional symbols.
 - 5.2.2.8. In every case the relevant operating mode used during the test procedure according to paragraph 1.1.1.1. of annex 6 and the allowed voltage(s) according to paragraph 1.1.1.2. of annex 6 shall be stipulated on the approval forms and on the communication forms transmitted to the countries which are Contracting Parties to the Agreement and which apply this Regulation.

In the corresponding cases the device shall be marked as follows:

On units meeting the requirements of this Regulation which are so designed that the filament of the passing beam shall not be lit simultaneously with that of any other lighting function with which it may be reciprocally incorporated:

an oblique stroke (/) shall be placed behind the passing lamp symbol in the approval mark.
- 5.2.2.9. The marks and symbols referred to in paragraphs 5.2.1. and 5.2.2. above shall be clearly legible and be indelible even when the optical unit is fitted in the vehicle.

^{3/} 1 for Germany, 2 for France, 3 for Italy, 4 for the Netherlands, 5 for Sweden, 6 for Belgium, 7 for Hungary, 8 for the Czech Republic, 9 for Spain, 10 for Yugoslavia, 11 for the United Kingdom, 12 for Austria, 13 for Luxembourg, 14 for Switzerland, 15 (vacant), 16 for Norway, 17 for Finland, 18 for Denmark, 19 for Romania, 20 for Poland, 21 for Portugal and 22 for the Russian Federation, 23 for Greece, 24 (vacant), 25 for Croatia, 26 for Slovenia, 27 for Slovakia, 28 for Belarus, 29 for Estonia, 30 (vacant), 31 for Bosnia and Herzegovina, 32-36 (vacant), 37 for Turkey, 38-39 (vacant) and 40 for The former Yugoslav Republic of Macedonia. Subsequent numbers will be assigned to other countries in the chronological order in which they ratify or accede to the Agreement Concerning the Adoption of Uniform Technical Prescriptions for Wheeled Vehicles, Equipment and Parts which can be Fitted and/or be Used on wheeled Vehicles and the Conditions for Reciprocal Recognition of Approvals Granted on the Basis of these Prescriptions, and the numbers thus assigned shall be communicated by the Secretary-General of the United Nations to the Contracting Parties to the Agreement.

5.3. Arrangement of the approval mark

5.3.1. Independent lamps

Annex 2, figures 1 to 7, to this Regulation gives examples of arrangements of the approval mark with the above-mentioned additional symbols.

5.3.2. Grouped, combined or reciprocally incorporated lamps

5.3.2.1. Where grouped, combined or reciprocally incorporated lamps have been found to comply with the requirements of several Regulations, a single international approval mark may be affixed, consisting of a circle surrounding the letter "E", followed by the distinguishing number of the country which has granted the approval, and an approval number. This approval mark may be located anywhere on the grouped, combined or reciprocally incorporated lamps, provided that:

5.3.2.1.1. it is visible after their installation;

5.3.2.1.2. no part of the grouped, combined or reciprocally incorporated lamps that transmits light can be removed without at the same time removing the approval mark.

5.3.2.2. The identification symbol for each lamp appropriate to each Regulation under which approval has been granted, together with the corresponding series of amendments incorporating the most recent major technical amendments to the Regulation at the time of issue of the approval and, if necessary, the required arrow shall be marked:

5.3.2.2.1. either on the appropriate light-emitting surface,

5.3.2.2.2. or in a group, in such a way that each of the grouped, combined or reciprocally incorporated lamps may be clearly identified (see four possible examples in annex 2).

5.3.2.3. The size of the components of a single approval mark shall not be less than the minimum size required for the smallest of the individual marks by the Regulation under which approval has been granted.

5.3.2.4. An approval number shall be assigned to each type approved. The same Contracting Party may not assign the same number to another type of grouped, combined or reciprocally incorporated lamps covered by this Regulation.

5.3.2.5. Annex 2, figure 8, to this Regulation gives examples of arrangements of approval marks for grouped, combined or reciprocally incorporated lamps with all the above-mentioned additional symbols.

5.3.3. Lamps, the lens of which is used for different types of lamps and which may be reciprocally incorporated or grouped with other lamps

The provisions laid down in paragraph 5.3.2. above are applicable.

5.3.3.1. In addition, where the same lens is used, the latter may bear the different approval marks relating to the different types of headlamps or units of lamps, provided that the main body of the HSB unit, even if it cannot be separated from the lens, also comprises the space described in paragraph 4.2. above and bears the approval mark of the actual functions.

If different types of HSB units comprise the same main body, the latter may bear the different approval marks.

- 5.3.3.2. Annex 2, figure 9, to this Regulation gives examples of arrangements of approval marks relating to the above case.

6. GENERAL SPECIFICATIONS

- 6.1. Every sample shall conform to the specifications set forth in this paragraph and in paragraphs 7. and 8. below and, if necessary, to those set forth in paragraph 9.
- 6.2. HSB units shall be so designed and made that in normal use, despite the vibrations to which they may then be subjected, their satisfactory operation continues to be ensured and they retain the characteristics prescribed by this Regulation.
- 6.2.1. HSB optical units shall be fitted with a device enabling them to be so adjusted on the vehicle as to comply with the rules applicable to them. Such a device need not be fitted on HSB optical unit insert if the use of such inserts is confined to vehicles on which the headlamp setting can be adjusted by other means.
- Where an HSB optical unit providing a driving beam and an HSB optical unit providing a passing beam are assembled as exchangeable subunits to form a composite unit, the adjusting device shall enable each HSB unit individually to be duly adjusted.
- 6.2.2. However, this will not apply to headlamp assemblies whose reflectors are indivisible. For this type of assembly the requirements of paragraph 8.3. of this Regulation shall apply. In the case where more than one light source is used to provide the main beam, the combined main-beam functions will be used to determine the maximum value of the illumination (EM).
- 6.3. The terminals shall be in electrical contact with the appropriate filament or filaments only and shall be robust and firmly fixed to the HSB unit.
- 6.4. HSB units shall comprise electrical connections in conformity with those shown in one of the patterns reproduced in annex 3 to this Regulation and shall be of the dimensions specified in that annex.
- 6.5. Complementary tests shall be done according to the requirements of annex 6 to ensure that in use there is no excessive change in photometric performance.
- 6.6. If the lens of the HSB unit is of plastic material, tests shall be done according to the requirements of annex 7.

7. RATED AND TEST VALUES

- 7.1. The rated voltage is 12 volts.^{4/}
- 7.2. The wattage shall not exceed 75 watts on the driving beam filament and 68 watts on the passing beam filament measured at a test voltage of 13.2 volts.

8. ILLUMINATION^{5/}

8.1. General specifications

- 8.1.1. HSB units shall be made so as to give adequate illumination without dazzle when emitting the passing beam and good illumination when emitting the driving beam.

^{4/} Requirements for HSB units with a rated voltage of 24 volts are under consideration.

^{5/} All photometric measurements shall be made at the rated voltage specified in paragraph 7.1.

- 8.1.2. The illumination produced by the HSB unit shall be determined by means of a vertical screen set up 25 m forward of the unit as shown in annex 4 to this Regulation.^{6/}
- 8.1.3. On this screen, the illumination referred to in paragraphs 8.2.5., 8.2.6. and 8.3. below shall be measured by means of a photoreceptor, the effective area of which shall be contained within a square of 65 mm side.
- 8.2. Requirements concerning the passing beam
- 8.2.1. The passing beam shall produce a "cut-off" I sharp enough to serve as a satisfactory means of adjustment. The "cut-off" shall be a horizontal straight line on the side opposite to the direction of the traffic for which the unit is intended. On the other side it shall not extend beyond either the broken line HV H1 H4 formed by a straight line HV H1 making a 45 degrees angle with the horizontal and a straight line H1 H4, 25 cm above the straight line hh, or the straight line HV H3, inclined at an angle of 15 degrees above the horizontal (see annex 4 to this Regulation). A "cut-off" extending beyond both line HV H2 and line H2 H4 and resulting from a combination of the above two possibilities shall in no circumstances be permitted.
- 8.2.2. The HSB unit shall be so aimed that on the passing beam:
- 8.2.2.1. in the case of HSB units designed to meet the requirements of right-hand traffic, the "cut-off" on the left half of the screen^{7/} is horizontal and, in the case of HSB units designed to meet the requirements of left-hand traffic, the "cut-off" on the right half of the screen is horizontal;
- 8.2.2.2. this horizontal part of the "cut-off" is situated on the screen 25 cm below the level hh (see annex 4 to this Regulation);
- 8.2.2.3. The "elbow" of the "cut-off" is on line vv.^{8/}
- 8.2.3. When so adjusted, the HSB unit need meet only the requirements laid down in paragraphs 8.2.5. and 8.2.6. below if approval thereof is sought solely for provision of a passing beam;^{9/} if it is intended to provide both a passing beam and a driving beam it shall meet the requirements laid down in paragraphs 8.2.5., 8.2.6. and 8.3.

^{6/} If, in the case of an HSB unit designed to meet the requirements of this Regulation in respect of the passing beam only, the focal axis diverges appreciably from the general direction of the beam, lateral adjustment shall be effected in the manner which best satisfies the requirements for illumination at points 75 R and 50 R for right-hand traffic and 75 L and 50 L for left-hand traffic.

^{7/} The test screen shall be wide enough to allow examination of the "cut-off" over a range of at least 5 degrees on either side of the line vv.

^{8/} If the beam does not have a "cut-off" with a clear "elbow", lateral adjustment shall be effected in the manner which best satisfies the requirements for illumination at points 75 R and 50 R for right-hand traffic and 75 L and 50 L for left-hand traffic.

^{9/} An HSB unit designed to emit a passing beam may incorporate a driving beam not subject to this specification.

- 8.2.4. Where an HSB unit so adjusted does not meet the requirements laid down in paragraphs 8.2.5., 8.2.6. and 8.3., its alignment may be changed provided that the axis of the beam is not displaced laterally by more than 1 degrees (= 44 cm) to the right or left. ^{10/} To facilitate alignment by means of the "cut-off", the unit may be partially occulted in order to sharpen the "cut-off".
- 8.2.5. The illumination produced on the screen by the passing beam shall meet the following requirements:

POINT ON MEASURING SCREEN		REQUIRED ILLUMINATION IN LUX
HSB UNITS FOR RIGHT-HAND TRAFFIC	HSB UNITS FOR LEFT-HAND TRAFFIC	
		<0.4
B 50 L	B 50 R	>12
75 L	75 L	<12
75 L	75 R	>12
50 L	50 R	<15
50 R	50 L	>6
50 V	50 V	>2
25 L	25 R	>2
25 R	25 L	<0.7
		>3
At any point in zone III		
“ “ “ “ IV		<2 x (E _{50R} or * E _{50L})
“ “ “ “ I		

* E_{50R} and E_{50L} are the illuminations actually measured.

- 8.2.6. There shall be no lateral variations detrimental to good visibility in any of the Zones I, II, III and IV.
- 8.3. Requirements concerning the driving beam
- 8.3.1. In the case of an HSB unit designed to provide a driving beam and a passing beam, measurements of the illumination produced on the screen by the driving beam shall be taken with the same HSB unit alignment as for measurements under paragraphs 8.2.5. and 8.2.6.; if the HSB unit provides a driving beam only, it shall be so adjusted that the area of maximum illumination is centred on the point of intersection HV of lines hh and vv; such an HSB unit need meet only the requirements laid down in paragraph 8.3.
- 8.3.2. The illumination produced on the screen by the driving beam shall meet the following requirements:
- 8.3.2.1. The point of intersection HV of lines hh and vv shall be situated within the isolux 80% of maximum illumination. This maximum value (EM) shall not be less than

^{10/} The limit of realignment of 1 degrees to the right or left is not incompatible with vertical realignment upward or downward. The latter is limited only by the requirements of paragraph 8.3. However, the horizontal part of the "cut-off" should not extend beyond the line hh (the provisions of paragraph 8.3. are not applicable to HSB units intended to meet the requirements of this Regulation only for provision of a passing beam).

48 lux. The maximum value (E_M) shall not exceed 240 lux; in addition, in the case of a combined passing and driving HSB unit, it shall in no case exceed 16 times the illumination measured for the passing beam at point 75 R (or 75 L).

- 8.3.2.1.1. The maximum intensity (I_M) of the driving beam expressed in thousands of candelas shall be calculated by the formula:

$$I_M = 0.625 E_M$$

- 8.3.2.1.2. The reference mark (I'_M) of this maximum intensity, referred to in paragraph 5.2.2.5., shall be obtained by the ratio:

$$I'_M = \frac{I_M}{3} = 0.208 E_M$$

This value shall be rounded off to the nearest value 7.5 12.5 - 17.5 25 - 27.5 37.5 45 - 50.

- 8.3.2.2. Starting from point HV, horizontally to the right and left, the illumination shall be not less than 24 lux up to a distance of 1.125 m and not less than 6 lux up to a distance of 2.25 m.

9. COLOUR

- 9.1. Approval may be obtained for HSB units emitting either white or selective yellow light.^{11/} Expressed in CIE trichromatic coordinates, the corresponding colorimetric characteristics for selective yellow light are as follows at the test voltage:

Limit towards red $y > 0.138 + 0.580x$

Limit towards green $y < 1.290x - 0.100$

Limit towards white $y > -x + 0.966$

Limit towards spectral value $y < -x + 0.992$

which can be expressed as follows:

dominant wave length: 575 to 585 nm

purity factor: 0.90 to 0.98

- 9.2. The illumination produced on the screen by a selective yellow passing beam shall meet the requirements of paragraphs 8.2.5. and 8.2.6. with the minimum illuminations multiplied by a factor of 0.85; the maximum illumination values remain the same.

10. GAUGING OF DISCOMFORT

The discomfort caused by the passing beam of HSB units shall be gauged.^{12/}

11. CONFORMITY OF PRODUCTION

- 11.1. Headlamps approved under this Regulation shall be so manufactured as to conform to the type approved by meeting the requirements set forth in paragraph 8 and 9.

^{11/} Notwithstanding the provisions of article 3 of the 1958 Agreement concerning the Adoption of Uniform Conditions of Approval and Reciprocal Recognition of Approval for Motor Vehicle Equipment and Parts, the approval of an HSB unit under this Regulation shall not prevent the Contracting Parties to the Agreement applying this Regulation from prohibiting, on vehicles registered in their territory, the use of HSB units emitting a beam of either white or selective yellow light.

^{12/} This requirement will be the subject to a recommendation to administrations.

- 11.2. In order to verify that the requirements of paragraph 11.1. are met, suitable controls of the production shall be carried out.
- 11.3. The holder of the approval shall in particular:
 - 11.3.1. ensure the existence of procedures for the effective control of the quality of products;
 - 11.3.2. have access to the control equipment necessary for checking the conformity to each approved type;
 - 11.3.3. ensure that data of test results are recorded and that related documents shall remain available for a period to be determined in accordance with the administrative service;
 - 11.3.4. analyze the results of each type of test in order to verify and ensure the stability of the product characteristics making allowance for variation of an industrial production;
 - 11.3.5. ensure that for each type of product at least the tests prescribed in annex 5 to this Regulation are carried out;
 - 11.3.6. ensure that any collecting of samples giving evidence of nonconformity with the type of test considered shall give rise to another sampling and another test. All the necessary steps shall be taken to re-establish the conformity of the corresponding production.
- 11.4. The competent authority which has granted type approval may at any time verify the conformity control methods applicable to each production unit.
 - 11.4.1. In every inspection, the test books and production survey records shall be presented to the visiting inspector.
 - 11.4.2. The inspector may take samples at random to be tested in the manufacturer's laboratory. The minimum number of samples may be determined in the light of results of the manufacturer's own checks.
 - 11.4.3. When the quality level appears unsatisfactory or when it seems necessary to verify the validity of the tests carried out in the application of paragraph 11.4.2. above, the inspector shall select samples, to be sent to the technical service which has conducted the type approval tests, using the criteria of annex 8.
 - 11.4.4. The competent authority may carry out any test prescribed in this Regulation. These tests will be on samples selected at random without causing distortion of the manufacturer's delivery commitments and in accordance with the criteria of annex 8.
 - 11.4.5. The competent authority shall strive to obtain a frequency of inspection of once every two years. However, this is at the discretion of the competent authority and their confidence in the arrangements for ensuring effective control of the conformity of production. In the case where negative results are recorded, the competent authority shall ensure that all necessary steps are taken to re-establish the conformity of production as rapidly as possible.
- 11.5. Headlamps with apparent defects are disregarded.
- 11.6. The reference mark is disregarded.

12. PENALTIES FOR NON-CONFORMITY OF PRODUCTION

12.1. The approval granted in respect of a type of HSB unit pursuant to this Regulation may be withdrawn if the requirements set forth above are not met, or if an HSB unit bearing the approval mark does not conform to the type approved.

12.2. If a Contracting Party to the Agreement applying this Regulation withdraws an approval it has previously granted, it shall forthwith so notify the other Contracting Parties applying this Regulation, by means of a communication form conforming to the model in annex 1 to this Regulation.

13. MODIFICATION AND EXTENSION OF APPROVAL OF A TYPE OF HALOGEN SEALED-BEAM HEADLAMP UNIT (HSB UNIT)

13.1. Every modification of the type of HSB unit shall be notified to the administrative department which approved the type of HSB unit. The department may then either:

13.1.1. Consider that the modifications made are unlikely to have an appreciable adverse effect and that in any case the HSB unit still complies with the requirements; or

13.1.1. Require a further test report from the technical service responsible for conducting the tests.

13.2. Confirmation or refusal of approval, specifying the alterations shall be communicated by the procedure specified in paragraph 5.1.4. above to the Parties to the Agreement applying this Regulation.

13.3. The competent authority issuing the extension of approval shall assign a series number for such an extension and inform thereof the other Parties to the 1958 Agreement applying this Regulation by means of a communication form conforming to the model in annex 1 to this Regulation.

14. PRODUCTION DEFINITELY DISCONTINUED

If the holder of an approval completely ceases to manufacture a type of HSB unit approved in accordance with this Regulation, he shall so inform the authority which granted the approval. Upon receiving the relevant communication, that authority shall inform thereof the other Parties to the 1958 Agreement applying this Regulation by means of a communication form conforming to the model in annex 1 to this Regulation.

15. TRANSITIONAL PROVISIONS

15.1. As from the date of entry into force of the 02 series of amendments to this Regulation no Contracting Party applying it shall refuse to grant approvals under this Regulation as amended by the 02 series of amendments.

15.2. As from 24 months after the date of entry into force mentioned in paragraph 15.1. above, Contracting Parties applying this Regulation shall grant approvals only if the type of HSB unit corresponds to the requirements of this Regulation as amended by the 02 series of amendments.

15.3. Existing approvals granted under this Regulation before the date mentioned in paragraph 15.2. above shall remain valid. However, Contracting Parties applying this Regulation may prohibit the fitting of HSB units which do not meet the requirements of this Regulation as amended by the 02 series of amendments:

15.3.1. on vehicles for which type approval or individual approval is granted more than 24 months after the date of entry into force mentioned in paragraph 15.1. above,

15.3.2. on vehicles first registered more than five years after the date of entry into force mentioned in paragraph 15.1. above.

16. NAMES AND ADDRESSES OF TECHNICAL SERVICES RESPONSIBLE FOR CONDUCTING APPROVAL TESTS AND OF ADMINISTRATIVE DEPARTMENTS

The Parties to the 1958 agreement applying this Regulation shall communicate to the United Nations Secretariat the names and addresses of the technical services responsible for conducting approval tests and of the administrative departments which grant approval and to which forms certifying approval or extension or refusal or withdrawal of approval, or production definitely discontinued, issued in other countries, are to be sent.

Annex 1
COMMUNICATION

(maximum format: A4 (210 x 297mm))



issued by: Name of administration:

.....
.....
.....

concerning: ^{2/} APPROVAL GRANTED
APPROVAL EXTENDED
APPROVAL REFUSED
APPROVAL WITHDRAWN
PRODUCTION DEFINITELY DISCONTINUED

of a type of: Halogen Sealed-Beam Headlamp Unit (HSB unit) pursuant to Regulation No. 31

Approval No. Extension No.

1. HSB unit submitted for approval as type ^{3/}
Colour of light emitted: white/selective yellow ^{2/}
Rated voltage.....
Rated wattage.....
2. The passing lamp filament may/may not ^{2/} be lit simultaneously with the driving lamp filament and/ or another reciprocally incorporated lamp.....
.....
3. Trade name or mark.....
4. Manufacturer's name and address.....
5. if applicable, name and address of manufacturer's representative
.....
6. Submitted for approval on.....
7. Technical service responsible for conducting approval tests.....

^{1/} Distinguishing number of the country which has granted/extended/ refused/withdrawn approval (see approval provisions in the Regulation).

^{2/} Strike out what does not apply.

^{3/} Indicate the appropriate marking selected from the list below:

HSCR, HSCR, HSCR, HSC, HSC, HSC, HSR, HSC/R, HSC/R, HSC/R, HSC/, HSC/,
→ <- -> , > <-> . → <-> →
HSC/, HSCR PL, HSCR PL, HSCR PL, HSC PL, HSC PL, HSC PL, HSC PL, HSR PL,
<-> <-> <-> <-> <->
HSC/R PL, HSC/R PL, HSC/PL, HSC/PL, HSC/PL
→ < → < >

8. Date of report issued by that service.....
9. Number of report issued by that service.....
10. Approval granted/extended/refused/withdrawn ^{2/}
11. Reason(s) of extension (if applicable).....
12. Maximum illumination (in lux) of the driving beam at 25 m from the HSB unit
.....(average for 5 units)
13. Place.....
14. Date.....
15. Signature.....
16. The attached drawing No.shows the unit.

Annex 2
EXAMPLES OF ARRANGEMENTS OF APPROVAL MARKS

1.

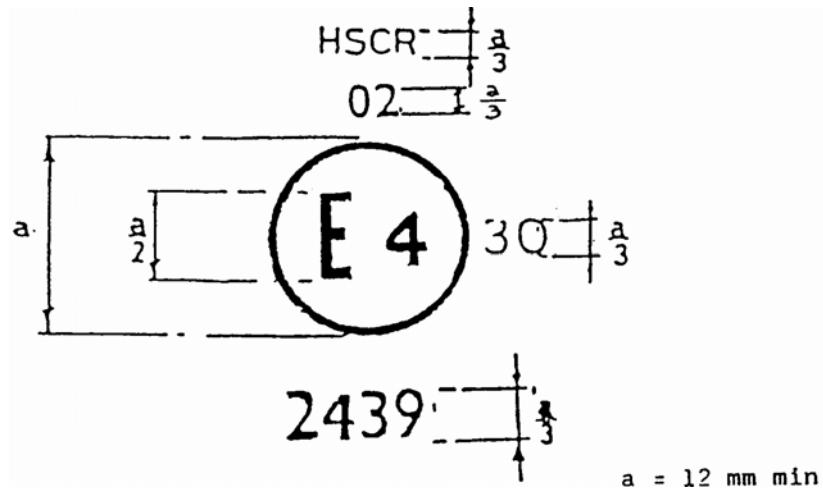

Figure 1

The above approval mark affixed to an HSB optical unit indicates that the unit concerned was approved in the Netherlands (E4) under number 2439, that it meets the requirements of this Regulation, as amended by the 02 series of amendments, in respect of both the driving beam and the passing beam, and that it is designed for right-hand traffic only.

The figure 30 indicates that the maximum intensity of the driving beam is between 86,250 and 101,250 candelas.

Note: The approval number and the additional symbol(s) shall be placed close to the circle and either above or below the letter "E", or to the right or left of that letter. The digits of the approval number shall be on the same side of the letter "E" and face the same direction. The use of Roman numerals as approval numbers should be avoided so as to prevent any confusion with other symbols.

2.

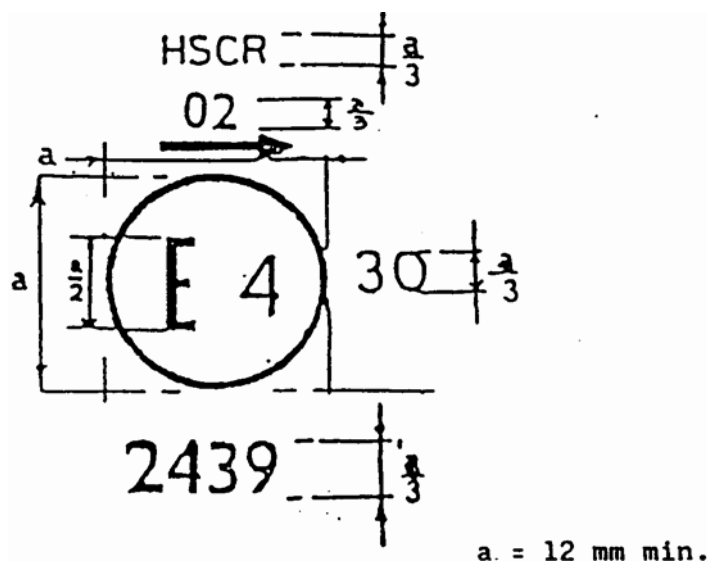

Figure 2

The above approval mark affixed to an HSB optical unit indicates that the unit concerned meets the requirements of this Regulation as amended by the 02 series of amendments, with respect to both the passing beam and the driving beam and that it is designed for left-hand traffic only.

3.

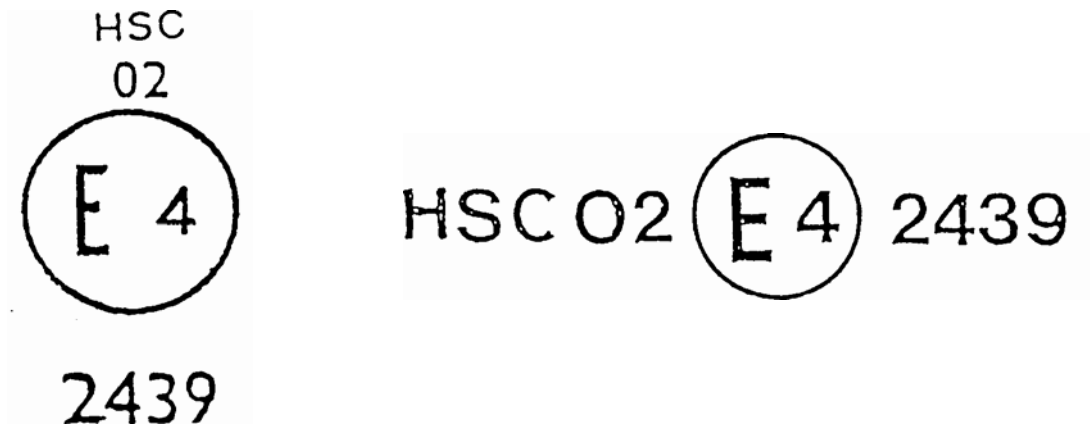

Figure 3a

Figure 3b

The above approval mark affixed to an HSB optical unit indicates that the unit concerned meets the requirements of this Regulation as amended by the 02 series of amendments, in respect of the passing beam only, and that it is designed for right-hand traffic only.

4.

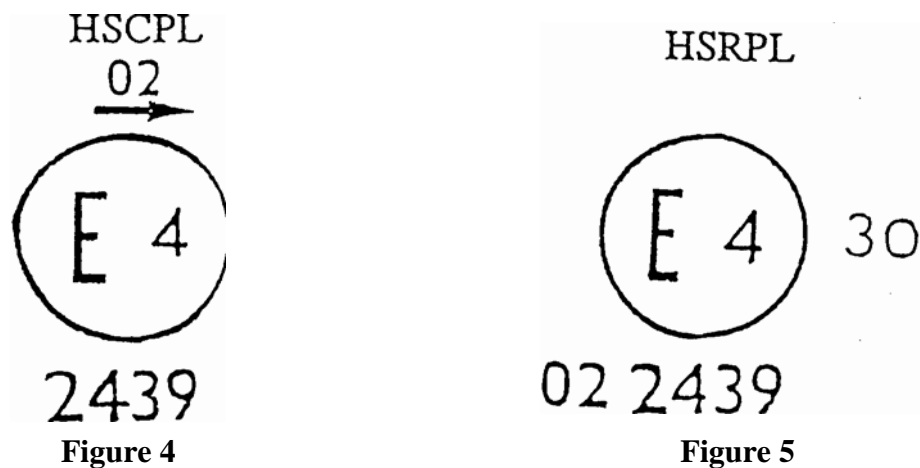

Figure 4

Figure 5

The above approval marks affixed to HSB optical units incorporating the lens of plastic material indicate that the units concerned meet the requirements of this Regulation, as amended by the 02 series of amendments:

figure 4 = With respect to the passing beam only, and that they are designed for left-hand traffic only.

figure 5 = With respect to the driving beam only.

The number 30 indicates that the maximum intensity of the driving beam is between 82,500 and 101,250 candelas.

5.

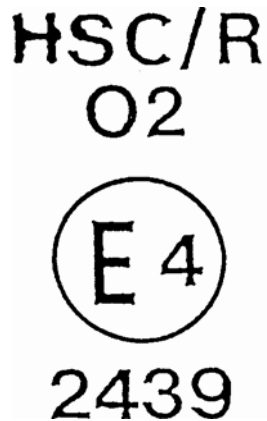

Figure 6

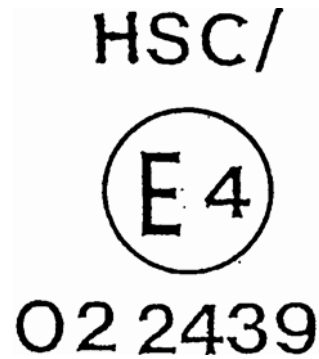

Figure 7

Identification of an HSB unit meeting the requirements of Regulation No. 31

figure 6 = with respect to both the passing beam and the driving beam and designed for right-hand traffic only.

figure 7 = with respect to the passing beam only and designed for right-hand traffic only. The passing lamp filament shall not be lit simultaneously with the driving lamp filament and/or another reciprocally incorporated lamp

6.

Figure 8

Simplified marking for grouped, combined or reciprocally incorporated lamps

(The vertical and horizontal lines schematize the shape of the light-signalling device. They are not part of the approval mark.)

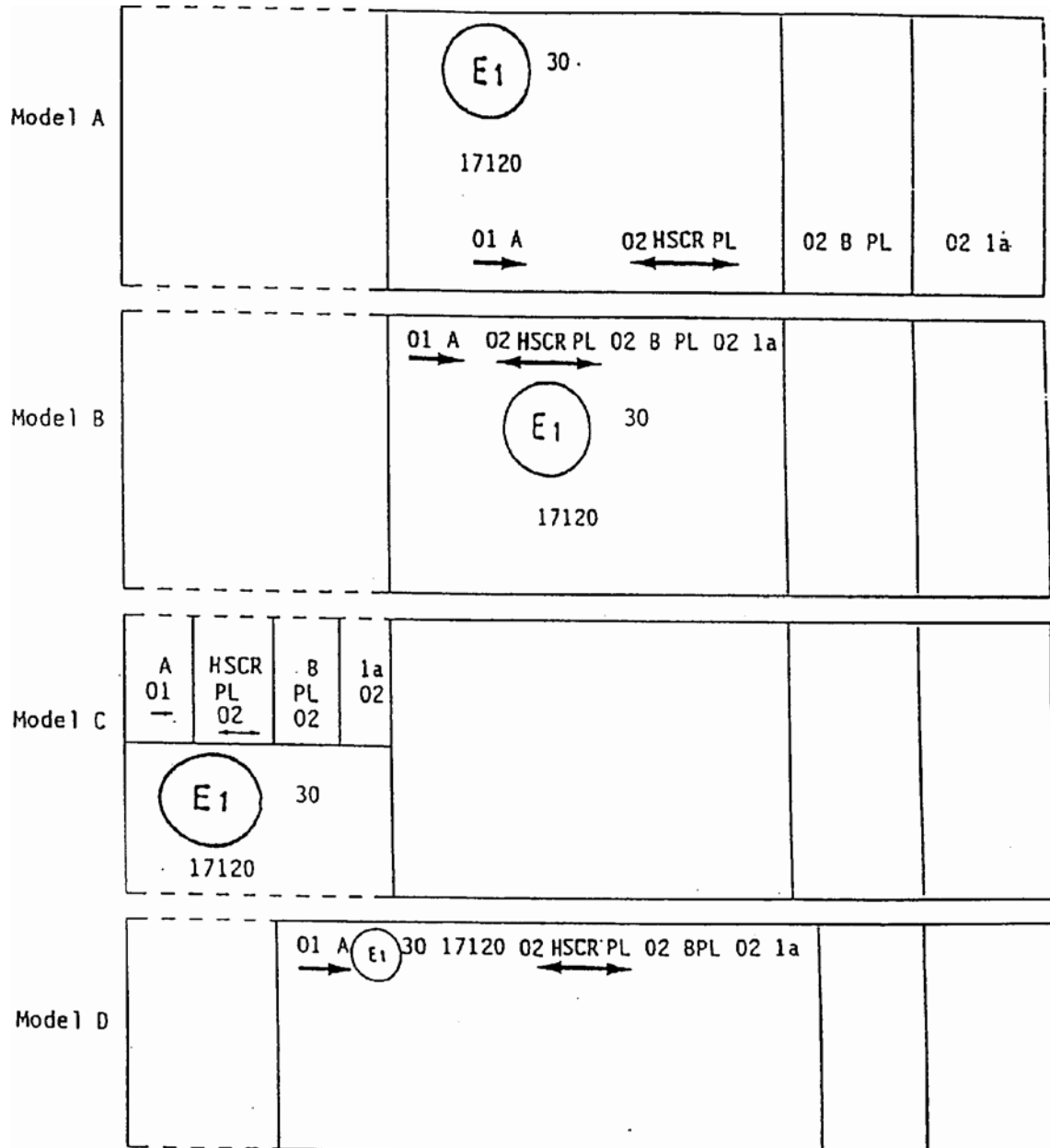

The four examples shown above correspond to a lighting device bearing an approval mark relating to:

A front position lamp approved in accordance with the 01 series of amendments to Regulation No. 7;

An HSB optical unit with a passing beam designed for right-hand and left-hand traffic and a driving beam with a maximum intensity comprised between 86,250 and 101,250 candelas (as indicated by the number 30), approved in accordance

with the 02 series of amendments to Regulation No. 31 and incorporating a lens of plastic material;

A front fog lamp approved in accordance with the 02 series of amendments to Regulation No. 19 and incorporating a lens of plastic material;

A front direction indicator lamp of category Ia, approved in accordance with the 02 series of amendments to Regulation No. 6.

7.

Figure 9

Lamp reciprocally incorporated with an HSB unit

Example 1

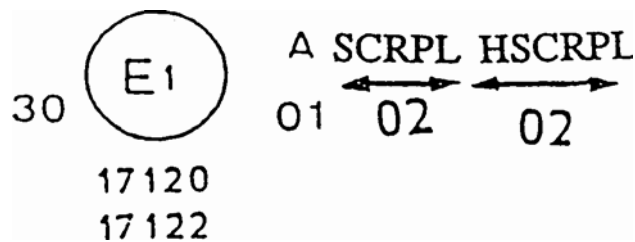

The above example corresponds to the marking of a lens of plastic material intended to be used in different types of HSB units, namely:

either: an HSB unit with a passing beam designed for right-hand and left-hand traffic and a driving beam approved in Germany (E1) in accordance with the requirements of Regulation No. 5 as amended by the 02 series of amendments, which is reciprocally incorporated with a front position lamp approved in accordance with the 01 series of amendments to Regulation No. 7;

or: an HSB unit with a passing beam designed for right-hand and left-hand traffic and a driving beam with a maximum intensity comprised between 86,250 and 101,250 candelas, approved in Germany (E1) in accordance with the requirements of Germany (E1) in accordance with the requirements of Regulation No. 31 as amended by the 02 series of amendments which is reciprocally incorporated with the same front position lamp as above;

or even: either of the above-mentioned HSB units approved as a single lamp.

The main body of the optical unit shall bear the only valid approval number, for instance:

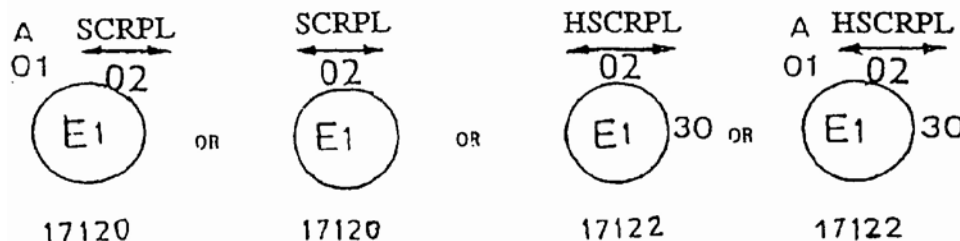

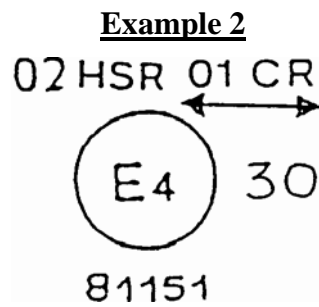

The above example corresponds to the marking of a lens used in an assembly of two HSB optical units approved in the Netherlands (E4), consisting of a headlamp emitting a passing beam designed for both traffic systems and of a driving beam meeting the requirements of Regulation No. 1, and of a headlamp emitting a driving beam meeting the requirements of Regulation No. 31.

Annex 3
ELECTRICAL CONNECTIONS OF HSB UNITS

Category 1 (Driving only)

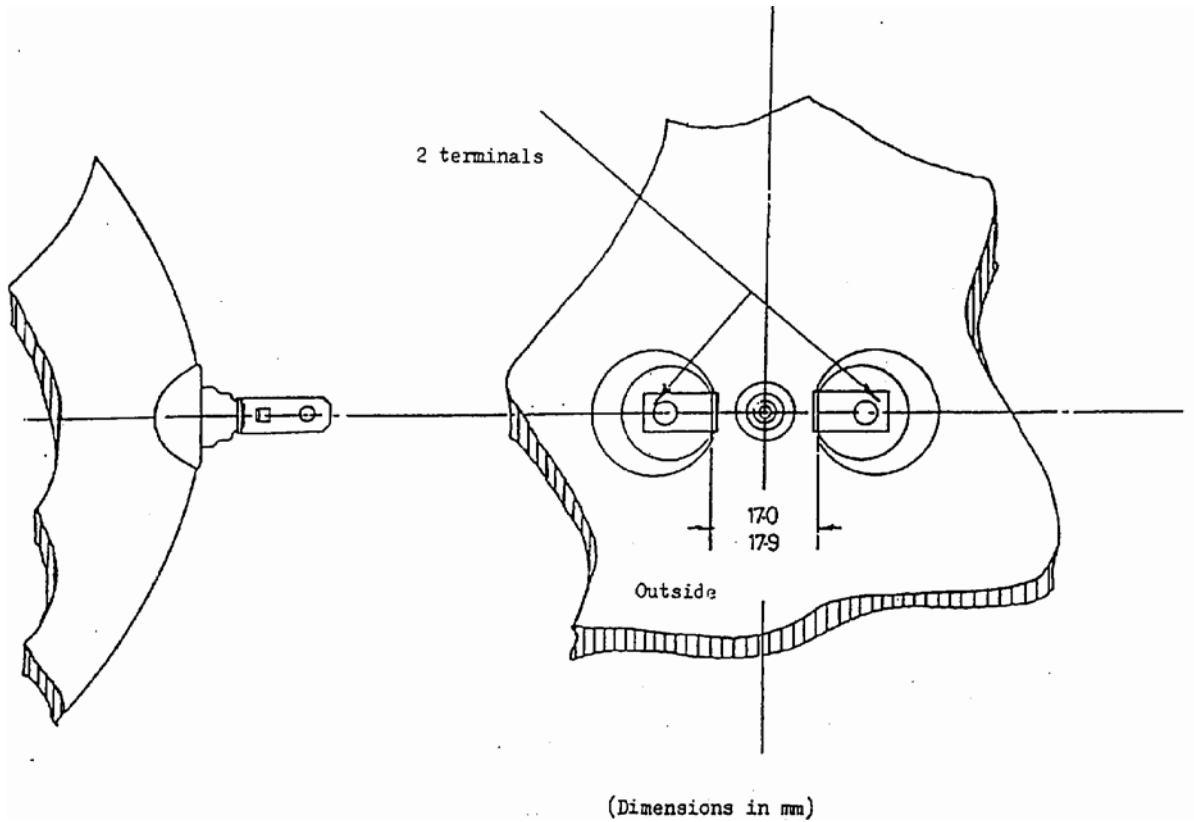

Fig. 1

Category 21 (Passing only)

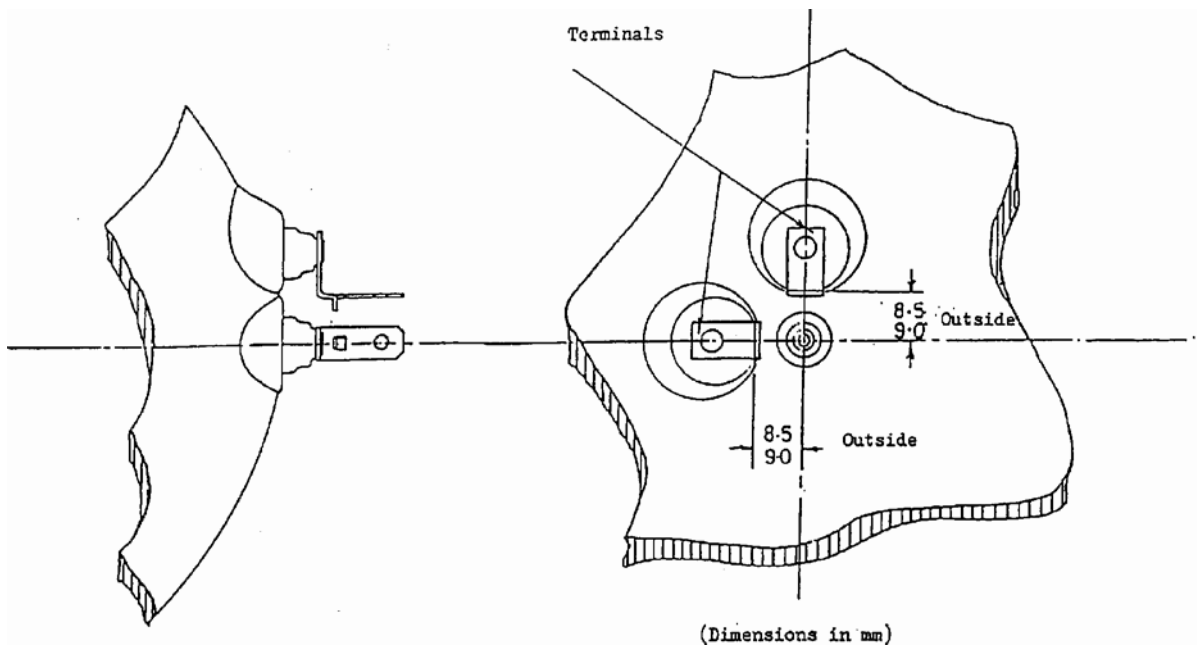

Fig. 2

Category 22 (Passing and driving)

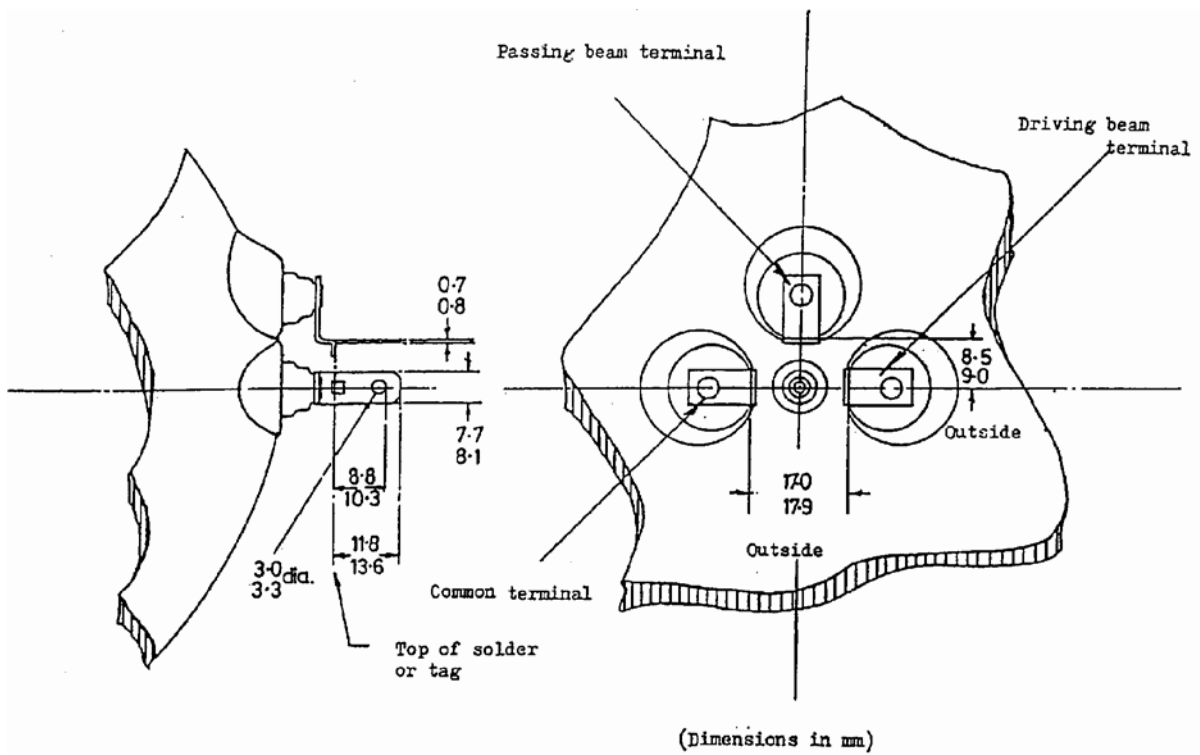
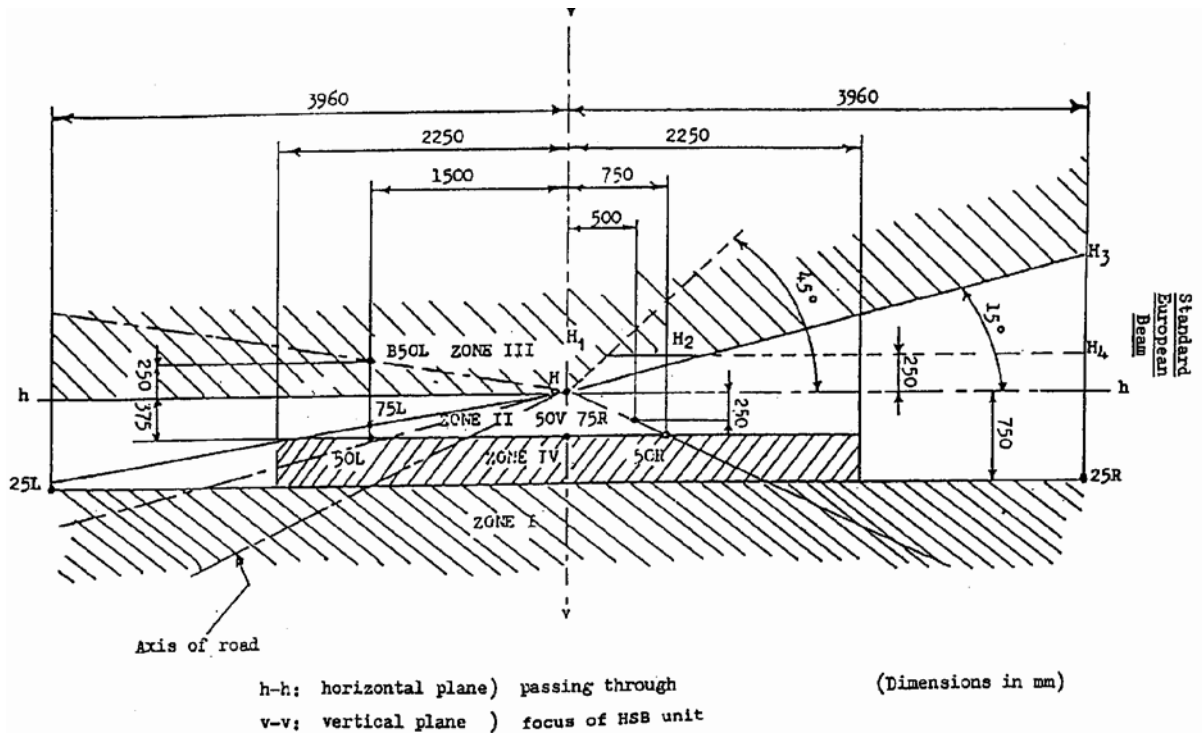
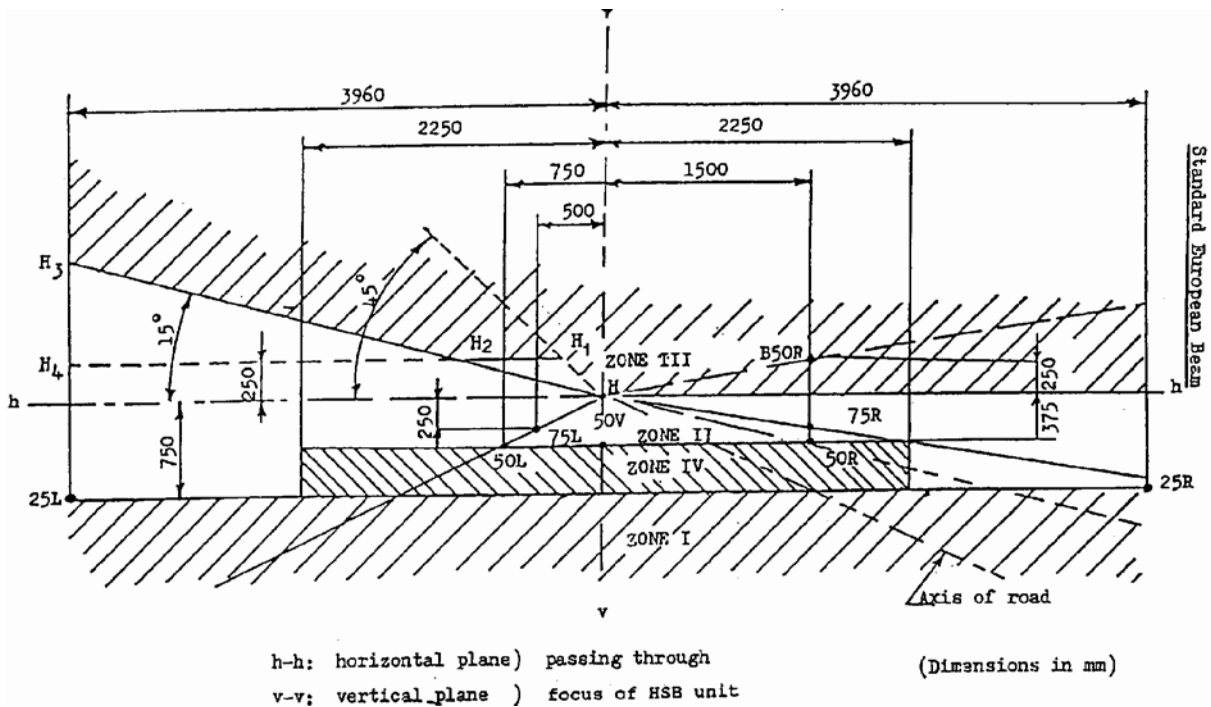

Fig. 3

Annex 4
MEASURING SCREEN
A. HSB unit for right-hand traffic



B. HBS unit for left-hand traffic



Annex 5

MINIMUM REQUIREMENTS FOR CONFORMITY OF PRODUCTION CONTROL PROCEDURES

1. GENERAL

- 1.1. The conformity requirements shall be considered satisfied from a mechanical and geometric standpoint, if the differences do not exceed inevitable manufacturing deviations within the requirements of this Regulation.
- 1.2. With respect to photometric performance, the conformity of mass-produced headlamps shall not be contested if, when testing photometric performance of any headlamp chosen at random:
- 1.2.1. no measured value deviates unfavourably by more than 20 % from the values prescribed in this Regulation. For values B 50 L (or R) and zone III, the maximum unfavourable deviation may be respectively:
- | | | |
|----------------|------|--------------------|
| B 50 L (or R): | 0.2 | lx equivalent 20 % |
| | 0.3 | lx equivalent 30 % |
| Zone III: | 0.3 | lx equivalent 20 % |
| | 0.45 | lx equivalent 30 % |
- 1.2.2. or if
- 1.2.2.1. for the passing beam, the values prescribed in this Regulation a met at HV (with a tolerance of + 0.2 lx) and related to that aiming at one point of each area delimited on the measuring screen (at 25 m) by a circle 15 cm in radius around points B 50 L (or R)^{1/} (with a tolerance of + 0.1 lx), 75 R (or L), 50 V, 25 R, 25 L, and in the entire area of zone IV which is not more than 22.5 cm above line 25 R and 25 L;
- 1.2.2.2. and if, for the driving beam, HV being situated within the isolux 0.75 E_{max}, a tolerance of + 20 % for maximum values and -20 % for minimum values is observed for the photometric values at any measuring point specified in paragraph 8.3. of this Regulation.
- 1.2.3. If the results of the tests described above do not meet the requirements, the alignment of the headlamp may be changed, provided that the axis of the beam is not displaced laterally by more than 1 degrees to the right or left.^{10/}
- 1.3. With respect to the verification of the change in vertical position of the cut-off line under the influence of heat, the following procedure shall be applied:
- One of the sampled headlamps shall be tested according to the procedure described in paragraph 2.1. of annex 6 after being subjected three consecutive times to the cycle described in paragraph 2.2.2. of annex 6.
- The headlamp shall be considered as acceptable if delta r does not exceed 1.5 mrad.

^{1/} Letters in brackets refer to headlamps intended for left-hand traffic.

^{10/} See the corresponding footnote in the text of the Regulation.

If this value exceeds 1.5 mrad but is not more than 2.0 mrad, a second headlamp shall be subjected to the test after which the mean of the absolute values recorded on both samples shall not exceed 1.5 mrad.

- 1.4. The chromaticity coordinates shall be complied with.

The photometric performance of a headlamp emitting selective yellow light shall be the values contained in this Regulation multiplied by 0.84.

2. MINIMUM REQUIREMENTS FOR VERIFICATION OF CONFORMITY BY THE MANUFACTURER

For each type of headlamp the holder of the approval mark shall carry out at least the following tests, at appropriate intervals. The tests shall be carried out in accordance with the provisions of this Regulation.

If any sampling shows non-conformity with respect to the type of test concerned, further samples shall be taken and tested. The manufacturer shall take steps to ensure the conformity of the production concerned.

2.1. Nature of tests

Tests of conformity in this Regulation shall cover the photometric characteristics and the verification of the change in vertical position of the cut-off line under the influence of heat.

2.2. Methods used in tests

- 2.2.1. Tests shall generally be carried out in accordance with the methods set out in this Regulation.

- 2.2.2. In any test of conformity carried out by the manufacturer, equivalent methods may be used with the consent of the competent authority responsible for approval tests. The manufacturer is responsible for proving that the applied methods are equivalent to those laid down in this Regulation.

- 2.2.3. The application of paragraphs 2.2.1. and 2.2.2. requires regular calibrations of test apparatus and its correlation with measurements made by a competent authority.

- 2.2.4. In all cases the reference methods shall be those of this Regulation, particularly for the purpose of administrative verification and sampling.

2.3. Nature of sampling

Samples of headlamps shall be selected at random from the production of a uniform batch. A uniform batch means a set of headlamps of the same type, defined according to the production methods of the manufacturer.

The assessment shall in general cover series production from individual factories. However, a manufacturer may group together records concerning the same type from several factories, provided these operate under the same quality system and quality management.

2.4. Measured and recorded photometric characteristics

The sampled headlamps shall be subjected to photometric measurements at the points provided for in the Regulation, the reading being limited to points E_{\max} ,

HV^{1/}, HL, HR^{2/} in the case of the driving beam, and to points B 50 L (or R), HV, 50 V, 75 R (or L) and 25 L (or R) in the case of the passing beam (see figure in annex 4).

2.5. Criteria governing acceptability

The manufacturer is responsible for carrying out a statistical study of the test results and for defining, in agreement with the competent authority, criteria governing the acceptability of his products in order to meet the specifications laid down for verification of conformity of products in paragraph 11.1. of this Regulation.

The criteria governing the acceptability shall be such that, with a confidence level of 95 %, the minimum probability of passing a spot check in accordance with annex 8 (first sampling) would be 0.95.

^{1/} When the driving beam is reciprocally incorporated with the passing beam, HV in the case of the driving beam shall be the same measuring point as in the case of the passing beam.

^{2/} HL and HR: points on "hh" located at 1.125 m to the left and to the right of point HV respectively.

Annex 6

TESTS FOR STABILITY OF PHOTOMETRIC PERFORMANCE OF HEADLAMPS IN OPERATION TESTS ON COMPLETE HEADLAMPS

Once the photometric values have been measured according to the prescriptions of this Regulation, in points for E max for driving beam and HV, 50 R, B 50 L for passing beam (or HV, 50 L, B 50 R for headlamps designed for left-hand traffic) a complete headlamp sample shall be tested for stability of photometric performance in operation. "Complete headlamp" shall be understood to mean the complete lamp itself including those surrounding body parts and lamps which could influence its thermal dissipation.

1. TEST OF STABILITY OF PHOTOMETRIC PERFORMANCE

The tests shall be carried out in a dry and still atmosphere at an ambient temperature of 23 degrees C +/- 5 degrees C, the complete headlamp being mounted on a base representing the correct installation on the vehicle.

1.1. Clean headlamp

The headlamp shall be operated for 12 hours as described in subparagraph 1.1.1. and checked as prescribed in subparagraph 1.1.2.

1.1.1. Test procedure

The headlamp shall be operated for a period according to the specified time, so that:

- (a) in the case where only one lighting function (driving or passing beam) is to be approved, the corresponding filament is lit for the prescribed time,^{2/}
- (b) in the case of a reciprocally incorporated passing lamp and driving lamp (dual filament HSB headlamp):

If the applicant declares that the headlamp is to be used with a single filament lit^{1/} at a time, the test shall be carried out in accordance with this condition, activating^{2/} each specified function successively for half the time specified in paragraph 1.1.;

In all other cases^{1/2/} the headlamp, shall be subjected to the following cycle until the time specified is reached:

15 minutes, passing-beam filament lit 5 minutes, all filaments lit.

- (c) in the case of grouped lighting functions all the individual functions shall be lit simultaneously for the time specified for individual lighting functions (a) also taking into account the use of reciprocally incorporated lighting functions (b), according to the manufacturer's specifications.

^{1/} Should two filaments be simultaneously lit when headlamp flashing is used, this shall not be considered as being normal use of both filaments simultaneously.

^{2/} When the tested headlamp is grouped and/or reciprocally incorporated with signalling lamps, the latter shall be lit for the duration of the test. In the case of a direction indicator lamp, it shall be lit in flashing operation mode with an on/off time ratio of approximately one to one.

1.1.1.2. Test voltage

The voltage shall be adjusted so as to supply 90% of the maximum wattage specified in this Regulation for the type(s) of HSB headlamp(s) concerned is (are) obtained.

1.1.2. Test results

1.1.2.1. Visual inspection

Once the headlamp has been stabilized to the ambient temperature, the headlamp lens and the external lens, if any, shall be cleaned with a clean, damp cotton cloth. It shall then be inspected visually; no distortion, deformation, cracking or change in colour of either the headlamp lens or the external lens, if any, shall be noticeable.

1.1.2.2. Photometric test

To comply with the requirements of this Regulation, the photometric values shall be verified in the following points:

Passing beam:

50 R - B 50 L - HV for headlamps designed for right-hand traffic

50 L - B 50 R - HV for headlamps designed for left-hand traffic

Driving beam:

Point of E_{\max}

Another aiming may be carried out to allow for any deformation of the headlamp base due to heat (the change of the position of the cut-off line is covered in para. 2 of this annex);

A 10% discrepancy between the photometric characteristics and the values measured prior to the test is permissible including the tolerances of the photometric procedure.

1.2. Dirty headlamp

After being tested as specified in subparagraph 1.1. above, the headlamp shall be operated for one hour as described in subparagraph 1.1.1., after being prepared as prescribed in subparagraph 1.2.1., and checked as prescribed in subparagraph 1.1.2.

1.2.1. Preparation of the headlamp

1.2.1.1. Test mixture

1.2.1.1.1. For headlamp with the outside lens in glass:

The mixture of water and a polluting agent to be applied to the headlamp shall be composed of:

9 parts by weight of silica sand with a particle size of 0-100 μm ,

1 part by weight of vegetal carbon dust (beechwood) with a particle size of 0-100 μm , 0.2 part by weight of NaCMC^{3/}, and
an appropriate quantity of distilled water, with a conductivity of < 1 mS/m.
The mixture must not be more than 14 days old.

1.2.1.1.2. For head lamp with outside lens in plastic material:

The mixture of water and polluting agent to be applied to the headlamp shall be composed of:

9 parts by weight of silica sand with a particle size of 0-100 μm ,
1 part by weight of vegetal carbon dust (beechwood) with a particle size of 0-100 μm , 0.2 part by weight of NaCMC^{3/},
13 parts by weight of distilled water with a conductivity of < 1 mS/m, and
2 + 1 parts by weight of surface-actant.^{4/}
The mixture must not be more than 14 days old.

1.2.1.2. Application of the test mixture to the headlamp

The test mixture shall be uniformly applied to the entire light emitting surface of the headlamp and then left to dry. This procedure shall be repeated until the illumination value has dropped to 15-20% of the values measured for each following point under the conditions described in paragraph 1 above:

Point of E_{max} in driving beam, photometric distribution for a driving/passing lamp,
Point of E_{max} in driving beam, photometric distribution for a driving lamp only,
50 R and 50 V^{5/} for a passing lamp only, designed for right-hand traffic,
50 L and 50 V^{5/} for a passing lamp only, designed for left-hand traffic.

1.2.1.3. Measuring equipment

The measuring equipment shall be equivalent to that used during headlamp approval tests.

2. TEST FOR CHANGE IN VERTICAL POSITION OF THE CUT-OFF LINE UNDER THE INFLUENCE OF HEAT

This test consists of verifying that the vertical drift of the cut-off line under the influence of heat does not exceed a specified value for an operating passing lamp.

The headlamp tested in accordance with paragraph 1.1., shall be subjected to the test described in 2.1., without being removed from or readjusted in relation to its test fixture.

^{3/} NaCMC represents the sodium salt of carboxymethylcellulose, customarily referred to as CMC. The NaCMC used in the dirt mixture shall have a degree of substitution (DS) of 0.6-0.7 and a viscosity of 200-300 cP for a 2% solution at 20 degrees C.

^{4/} The tolerance on quantity is due to the necessity of obtaining a dirt that correctly spreads out on all the plastic lens.

^{5/} 50 V is situated 375 mm below HV on the vertical line v-v on the screen at 25 m distance.

2.1. Test

The test shall be carried out in a dry and still atmosphere at an ambient temperature of 23 degrees C +/- 5 degrees C.

Using a mass production HSB headlamp which has been aged for at least one hour the headlamp shall be operated on passing beam without being dismantled from or readjusted in relation to its test fixture. (For the purpose of this test, the voltage shall be adjusted as specified in para. 1.1.1.2.). The position of the cut-off line in its horizontal part (between vv and the vertical line passing through point B 50 L for right-hand traffic or B 50 R for left-hand traffic) shall be verified 3 minutes (r_3) and 60 minutes (r_{60}) respectively after operation.

The measurement of the variation in the cut-off line position as described above shall be carried out by any method giving acceptable accuracy and reproducible results.

2.2. Test results

2.2.1. The result expressed in milliradians (mrad) shall be considered as acceptable when the absolute value $\Delta r_I = |r_3 - r_{60}|$ recorded on the headlamp is not more than 1.0 mrad ($\Delta r_I < 1.0 \text{ mrad}$).

2.2.2. However, if this value is more than 1.0 mrad but not more than 1.5 mrad ($1.0 \text{ mrad} < \Delta r_I < 1.5 \text{ mrad}$) a second headlamp shall be tested as described in 2.1. after being subjected three consecutive times to the cycle as described below, in order to stabilize the position of mechanical parts of the headlamp on a base representative of the correct installation on the vehicle:

operation of the passing lamp for one hour, (the voltage shall be adjusted as specified in paragraph 1.1.1.2.),

Period of rest for one hour.

The headlamp type shall be considered as acceptable if the mean value of the absolute values Δr_I measured on the first sample and Δr_{II} measured on the second sample is not more than 1.0 mrad

$$\left(\frac{\Delta r_I + \Delta r_{II}}{2} \leq 1.0 \text{ mrad} \right)$$

Annex 7

REQUIREMENTS FOR LAMPS INCORPORATING LENSES OF PLASTIC MATERIAL- TESTING OF LENS OR MATERIAL SAMPLES AND OF COMPLETE LAMPS

1. GENERAL SPECIFICATIONS

- 1.1. The samples supplied pursuant to paragraph 3.2.4. of this Regulation shall satisfy the specifications indicated in paragraphs 2.1. to 2.5. below.
- 1.2. Two out of the five samples of complete lamps supplied pursuant to paragraph 3.2.3. of this Regulation and incorporating lenses of plastic material shall, with regard to the lens material, satisfy the specifications indicated in paragraph 2.6. below.
- 1.3. The samples of lenses of plastic material or samples of material shall be subjected, with the reflector to which they are intended to be fitted (where applicable), to approval tests in the chronological order indicated in table A reproduced in appendix 1 to this annex.
- 1.4. However, if the lamp manufacturer can prove that the product has already passed the tests prescribed in paragraphs 2.1.-2.5. below, or the equivalent tests pursuant to another Regulation, those tests need not be repeated; only the tests prescribed in appendix 1, table B, shall be mandatory.

2. TESTS

2.1. Resistance to temperature changes

2.1.1. Tests

Three new samples (lenses) shall be subjected to five cycles of temperature and humidity (RH = relative humidity) change in accordance with the following programme: 3 hours at 40 degrees C +/- 2 degrees C and 85-95% RH;

1 hour at 23 degrees C +/- 5 degrees C and 60-75% RH;

15 hours at -30 degrees C +/- 2 degrees C;

1 hour at 23 degrees C +/- 5 degrees C and 60-75% RH;

3 hours at 80 degrees C +/- 2 degrees C;

1 hour at 23 degrees C +/- 5 degrees C and 60-75% RH;

Before this test, the samples shall be kept at 23 degrees C +/- 5 degrees C and 60-75% RH for at least four hours.

Note: The periods of one hour at 23 degrees C +/- 5 degrees C shall include the periods of transition from one temperature to another which are needed in order to avoid thermal shock effects.

2.1.2. Photometric measurements

2.1.2.1. Method

Photometric measurements shall be carried out on the samples before and after the test. These measurements shall be made using a standard lamp, at the following points:

B 50 L and 50 R for the passing beam of a passing lamp or a passing/driving lamp (B 50 R and 50 L in the case of headlamps intended for left-hand traffic);

E_{\max} route for the driving beam of a driving lamp or a passing/driving lamp;

2.1.2.2. Results

The variation between the photometric values measured on each sample before and after the test shall not exceed 10% including the tolerances of the photometric procedure.

2.2. Resistance to atmospheric and chemical agents

2.2.1. Resistance to atmospheric agents

Three new samples (lenses or samples of material) shall be exposed to radiation from a source having a spectral energy distribution similar to that of a black body at a temperature between 5,500K and 6,000K. Appropriate filters shall be placed between the source and the samples so as to reduce as far as possible radiations with wave lengths smaller than 295 nm and greater than 2,500 nm. The samples shall be exposed to an energetic illumination of $1,200 \text{ W/m}^2 \pm 200 \text{ W/m}^2$ for a period such that the luminous energy that they receive is equal to $4,500 \text{ MJ/m}^2 \pm 200 \text{ MJ/m}^2$. Within the enclosure, the temperature measured on the black panel placed on a level with the samples shall be 50 degrees C \pm 5 degrees C. In order to ensure a regular exposure, the samples shall revolve around the source of radiation at a speed between 1 and 5 1/min.

The samples shall be sprayed with distilled water of conductivity lower than 1 mS/m at a temperature of 23 degrees C \pm 5 degrees C, in accordance with the following cycle:

spraying: 5 minutes;

drying: 25 minutes.

2.2.2. Resistance to chemical agents

After the test described in paragraph 2.2.1. above and the measurement described in paragraph 2.2.3.1. below have been carried out, the outer face of the said three samples shall be treated as described in paragraph 2.2.2.2. with the mixture defined in paragraph 2.2.2.1. below.

2.2.2.1. Test mixture

The test mixture shall be composed of 61.5% n-heptane, 12.5% toluene, 7.5% ethyl tetrachloride, 12.5% trichloroethylene and 6% xylene (volume per cent).

2.2.2.2. Application of the test mixture

Soak a piece of cotton cloth (as per ISO 105) until saturation with the mixture defined in paragraph 2.2.2.1. above and, within 10 seconds, apply it for 10 minutes to the outer face of the sample at a pressure of 50 N/cm², corresponding to an effort of 100 N applied on a test surface of 14 x 14 mm.

During this 10-minute period, the cloth pad shall be soaked again with the mixture so that the composition of the liquid applied is continuously identical with that of the test mixture prescribed.

During the period of application, it is permissible to compensate the pressure applied to the sample in order to prevent it from causing cracks.

2.2.2.3. Cleaning

At the end of the application of the test mixture, the samples shall be dried in the open air and then washed with the solution described in paragraph 2.3. (Resistance to detergents) at 23 degrees C +/- 5 degrees C.

Afterwards the samples shall be carefully rinsed with distilled water containing not more than 0.2% impurities at 23 degrees C +/- 5 degrees C and then wiped off with a soft cloth.

2.2.3. Results

2.2.3.1. After the test of resistance to atmospheric agents, the outer face of the samples shall be free from cracks, scratches, chipping and deformation, and the mean variation in transmission

$$\Delta t = \frac{T2 - T3}{T_2}$$

, measured on the three samples according to the procedure described in appendix 2 to this annex shall not exceed 0.020 ($\Delta t_m < 0.020$).

2.2.3.2. After the test of resistance to chemical agents, the samples shall not bear any traces of chemical staining likely to cause a variation of flux diffusion, whose mean variation

$$\Delta d = \frac{|T5 - T4|}{T_2}$$

, measured on the three samples according to the procedure described in appendix 2 to this annex shall not exceed 0.020 ($\Delta d_m < 0.020$).

2.3. Resistance to detergents and hydrocarbons

2.3.1. Resistance to detergents

The outer face of three samples (lenses or samples of material) shall be heated to 50 degrees C +/- 5 degrees C and then immersed for five minutes in a mixture maintained at 23 degrees C +/- 5 degrees C and composed of 99 parts distilled water containing not more than 0.02% impurities and one part alkylaryl sulphonate.

At the end of the test, the samples shall be dried at 50 degrees C +/- 5 degrees C. The surface of the samples shall be cleaned with a moist cloth.

2.3.2. Resistance to hydrocarbons

The outer face of these three samples shall then be lightly rubbed for one minute with a cotton cloth soaked in a mixture composed of 70% n-heptane and 30% toluene (volume per cent), and shall then be dried in the open air.

2.3.3. Results

After the above two tests have been performed successively, the mean value of the variation in transmission

$$\Delta t = \frac{|T2 - T3|}{T_2}$$

, measured on the three samples according to the procedure described in appendix 2 to this annex shall not exceed 0.010 ($\Delta t_m < 0.010$).

2.4. Resistance to mechanical deterioration

2.4.1. Mechanical deterioration method

The outer face of the three new samples (lenses) shall be subjected to the uniform mechanical deterioration test by the method described in appendix 3 to this annex.

2.4.2. Results

After this test, the variations: in transmission:

$$\Delta t = \frac{T_2 - T_3}{T_2}$$

and in diffusion:

$$\Delta t = \frac{T_5 - T_4}{T_2}$$

shall be measured according to the procedure described in appendix 2 in the area specified in paragraph 3.2.4.1.1. of this Regulation. The mean value of the three samples shall be such that: $\Delta t_m < 0.100$;

$$\Delta d_m < 0.050.$$

2.5. Test of adherence of coatings, if any

2.5.1. Preparation of the sample

A surface of 20 mm x 20 mm in area of the coating of a lens shall be cut with a razor blade or a needle into a grid of squares approximately 2 mm x 2 mm. The pressure on the blade or needle shall be sufficient to cut at least the coating.

2.5.2. Description of the test

Use an adhesive tape with a force adhesion of 2 N/(cm of width) +/- 20% measured under the standardized conditions specified in appendix 4 to this annex.

This adhesive tape, which shall be at least 25 mm wide, shall be pressed for at least five minutes to the surface prepared as prescribed in paragraph 2.5.1.

Then the end of the adhesive tape shall be loaded in such a way that the force of adhesion to the surface considered is balanced by a force perpendicular to that surface. At this stage, the tape shall be torn off at a constant speed of 1.5 m/s +/- 0.2 m/s.

2.5.3. Results

There shall be no appreciable impairment of the gridded area. Impairments at the intersections between squares or at the edges of the cuts shall be permitted, provided that the impaired area does not exceed 15 % of the gridded surface.

2.6. Tests of the complete lamp incorporating a lens of plastic material

2.6.1. Resistance to mechanical deterioration of the lens surface

2.6.1.1. Tests

The lens of lamp sample No. 1 shall be subjected to the test described in paragraph 2.4.1. above.

2.6.1.2. Results

After the test, the results of photometric measurements carried out on the lamp in accordance with this Regulation shall not exceed by more than 30% the maximum values prescribed at points B 50 L and HV and not be more than 10% below the minimum values prescribed at point 75 R (in the case of headlamps intended for left- hand traffic, the points to be considered are B 50 R, HV and 75 L).

2.6.2. Test of adherence of coatings, if any

The lens of lamp sample No. 2 shall be subjected to the test described in paragraph 2.5. above.

3. VERIFICATION OF THE CONFORMITY OF PRODUCTION

3.1. With regard to the materials used for the manufacture of lenses, the lamps of a series shall be recognized as complying with this, Regulation if:

3.1.1. After the test for resistance to chemical agents and the test for resistance to detergents and hydrocarbons, the outer face of the samples exhibits no cracks, chipping or deformation visible to the naked eye (see paras. 2.2.2., 2.3.1. and 2.3.2.);

3.1.2. After the test described in paragraph 2.6.1.1., the photometric values at the points of measurement considered in paragraph 2.6.1.2. are within the limits prescribed for conformity of production by this Regulation.

3.2. If the test results fail to satisfy the requirements, the tests shall be repeated on another sample of headlamps selected at random.

Annex 7 - Appendix 1

CHRONOLOGICAL ORDER OF APPROVAL TESTS

A. Tests on plastic materials (lenses or samples of material supplied pursuant to paragraph 3.2.4. of this Regulation).

Tests	Sample	Lenses or samples					Samples							
		1	2	3	4	5	6	7	8	9	10	11	12	13
1.1. Limited photometry(para. 2.1.2)											x	x	x	
1.1.1. Temperature change(para. 2.1.1)											x	x	x	
1.1.2. Limited photometry(para. 2.1.2)											x	x	x	
1.2.1. Transmission measurement		x	x	x	x	x	x	x	x	x				
1.2.2. Diffusion measurement		x	x	x				x	x	x				
1.3. Atmospheric agents(para. 2.2.1)		x	x	x										
1.3.1. Transmission measurement		x	x	x										
1.4. Chemicals agents(para. 2.2.2)		x	x	x										
1.4.1. Diffusion measurement		x	x	x										
1.5. Detergents(para. 2.3.1)						x	x	x						
1.6. Hydrocarbons(para. 2.3.2)						x	x	x						
1.6.1. Transmission measurement						x	x	x						
1.7. Deterioration(para. 2.4.1)									x	x	x			
1.7.1. Transmission measurement									x	x	x			
1.7.2. Diffusion measurement									x	x	x			
1.8. Adherence(para. 2.5)														x

B. Tests on complete lamps (supplied pursuant to paragraph 3.2.3. of this Regulation).

Tests	Complete headlamp	
	Sample no.	
	1	2
2.1. Deterioration(para. 2.6.1.1)	X	
2.2. Photometry(para. 2.6.1.2)	X	
2.3. Adherence(para. 2.6.2)	X	
		X

Annex 7 - Appendix 2

METHOD OF MEASUREMENT OF THE DIFFUSION AND TRANSMISSION OF LIGHT

1. EQUIPMENT (see figure)

The beam of a collimator K with a half divergence

$$\frac{\beta}{2} = 17.4 \times 10^{-4} \text{ rd}$$

is limited by a diaphragm DT with an opening of 6 mm against which the sample stand is placed.

A convergent achromatic lens L₂, corrected for spherical aberrations, links the diaphragm D_T with the receiver R; the diameter of the lens L₂ shall be such that it does not diaphragm the light diffused by the sample in a cone with a half top angle of beta/2 = 14 degrees .

An annular diaphragm D_D with angles

$$\frac{\alpha_0}{2} = 1^\circ \text{ and } \frac{\alpha_{\max}}{2} = 12^\circ$$

is placed in an image focal plane of the lens L₂.

The non-transparent central part of the diaphragm is necessary in order to eliminate the light arriving directly from the light source. It shall be possible to remove the central part of the diaphragm from the light beam in such a manner that it returns exactly to its original position.

The distance L₂ D_T and the focal length F₂^{1/} of the lens L₂ shall be so chosen that the image of D_T completely covers the receiver R.

When the initial incident flux is referred to 1,000 units, the absolute precision of each reading shall be better than 1 unit.

2. MEASUREMENTS

The following readings shall be taken:

Reading	With sample	With central part of D _D	Quantity represented
T ₁	No	No	Incident flux in initial reading
T ₂	Yes (before test)	No	Flux transmitted by the new material in a field of 24 degrees C
T ₃	Yes (after test)	No	Flux transmitted by the tested material in a field of 24 degrees C
T ₄	Yes (before test)	Yes	Flux diffused by the new material
T ₅	Yes (after test)	Yes	Flux diffused by the tested material

^{1/} For L₂ it is recommended to use a focal distance of about 80 mm.

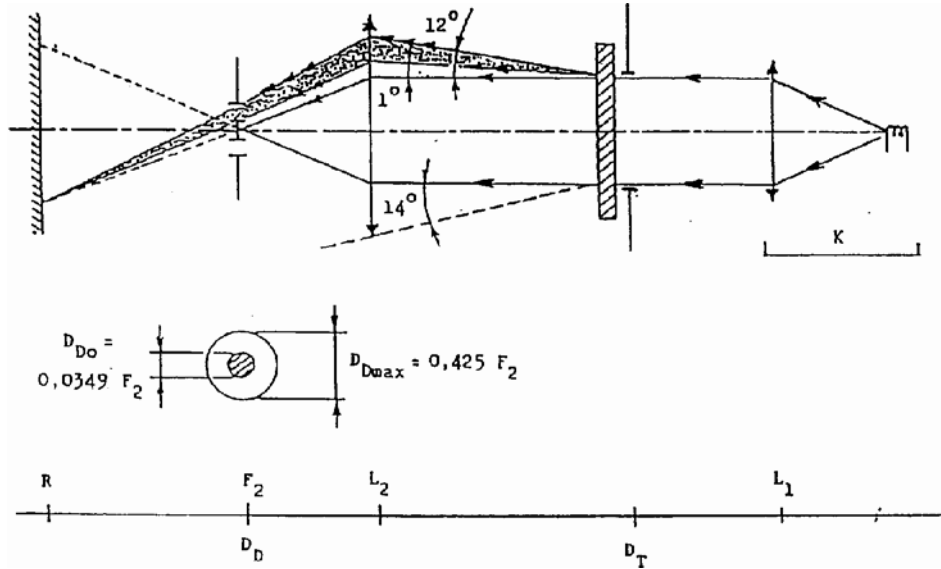

Annex 7 - Appendix 3

SPRAY TESTING METHOD

1. Test equipment

1.1. Spray gun

The spray gun used shall be equipped with a nozzle 1.3 mm in diameter allowing a liquid flow rate of 0.24 +/- 0.02 l/minute at an operating pressure of 6.0 bars - 0, + 0.5 bar. Under these operation conditions the fan pattern obtained shall be 170 mm +/- 50 mm in diameter on the surface exposed to deterioration, at a distance of 380 mm +/- 10 mm from the nozzle.

1.2. Test mixture

The test mixture shall be composed of:

Silica sand of hardness 7 on the Mohr scale, with a grain size between 0 and 0.2 mm and an almost normal distribution, with an angular factor of 1.8 to 2;

Water of hardness not exceeding 205 g/m³ for a mixture comprising 25 g of sand per litre of water.

2. Test

The outer surface of the lamp lenses shall be subjected once or more than once to the action of the sand jet produced as described above. The jet shall be sprayed almost perpendicular to the surface to be tested.

The deterioration shall be checked by means of one or more samples of glass placed as a reference near the lenses to be tested. The mixture shall be sprayed until the variation in the diffusion of light on the sample or samples measured by the method described in appendix 2, is such that:

$$\Delta d = \frac{T5 - T4}{T2} = 0.0250 \pm 0.0025$$

Several reference samples may be used to check that the whole surface to be tested has deteriorated homogeneously.

Annex 7 - Appendix 4

ADHESIVE TAPE ADHERENCE TEST

1. PURPOSE

This method allows to determine under standard conditions the linear force of adhesion of an adhesive tape to a glass plate.

2. PRINCIPLE

Measurement of the force necessary to unstick an adhesive tape from a glass plate at an angle of 90 degrees.

3. SPECIFIED ATMOSPHERIC CONDITIONS

The ambient conditions shall be at 23 degrees C +/- 5 degrees C and 65 +/- 15% relative humidity (RH).

4. TEST PIECES

Before the test, the sample roll of adhesive tape shall be conditioned for 24 hours in the specified atmosphere (see para. 3 above).

Five test pieces each 400 mm long shall be tested from each roll. These test pieces shall be taken from the roll after the first three turns were discarded.

5. PROCEDURE

The test shall be under the ambient conditions specified in paragraph 3.

Take the five test pieces while unrolling the tape radially at a speed of approximately 300 mm/s, then apply them within 15 seconds in the following manner:

Apply the tape to the glass plate progressively with a slight lengthwise rubbing movement of the finger, without excessive pressure, in such a manner as to leave no air bubble between the tape and the glass plate.

Leave the assembly in the specified atmospheric conditions for 10 minutes.

Unstick about 25 mm of the test piece from the plate in a plane perpendicular to the axis of the test piece.

Fix the plate and fold back the free end of the tape at 90 degrees. Apply force in such a manner that the separation line between the tape and the plate is perpendicular to this force and perpendicular to the plate.

Pull to unstick at a speed of 300 mm/s +/- 30 mm/s and record the force required.

6. RESULTS

The five values obtained shall be arranged in order and the median value taken as the result of the measurement. This value shall be expressed in Newtons per centimetre of width of the tape.

Annex 8

MINIMUM REQUIREMENTS FOR SAMPLING BY AN INSPECTOR

1. GENERAL

1.1. The conformity requirements shall be considered satisfied from a mechanical and a geometric standpoint, in accordance with the requirements of this Regulation, if any, if the differences do not exceed inevitable manufacturing deviations.

1.2. With respect to photometric performance, the conformity of mass-produced headlamps shall not be contested if, when testing photometric performance of any headlamp chosen at random;

1.2.1. no measured value deviates unfavourably by more than 20 % from the values prescribed in this Regulation.

For values B 50 L (or R) and Zone III the maximum deviation may be respectively:

B 50 L (or R):	0.2 lx	equivalent 20 %
	0.3 lx	equivalent 30 %
Zone III:	0.3 lx	equivalent 20 %
	0.45 lx	equivalent 30 %

1.2.2. or if

1.2.2.1. for the passing beam, the values prescribed in this Regulation are met at HV (with a tolerance of 0.2 lx) and related to that aiming at least one point of each area delimited on the measuring screen (at 25 m) by a circle 15 cm in radius around points B 50 L (or R)^{1/} (with a tolerance of 0.1 lx), 75 R (or L), 50 V, 25 R, 25 L, and in the entire area of zone IV which is not more than 22.5 cm above line 25 R and 25 L;

1.2.2.2. and if, for the driving beam, HV being situated within the isolux 0.75 E_{max}, a tolerance of + 20 % for maximum values and - 20 % for minimum values is observed for the photometric values at any measuring point specified in paragraph 8.3. of this Regulation. The reference mark is disregarded.

1.2.3. If the results of the tests described above do not meet the requirements, the alignment of the headlamp may be changed, provided that the axis of the beam is not displaced laterally by more than 1 degree to the right or left.^{10/}

1.2.4. Headlamps with apparent defects are disregarded.

1.2.5. The reference mark is disregarded.

1.3. The photometric performance of a headlamp emitting selective yellow light shall be the values contained in this Regulation multiplied by 0.84.

2. FIRST SAMPLING

In the first sampling four headlamps are selected at random. The first sample of two is marked A, the second sample of two is marked B.

^{1/} Letters in brackets refer to headlamps intended for left-hand traffic.

^{10/} See the corresponding footnote in the text of the Regulation.

2.1. The conformity is not contested

2.1.1. Following the sampling procedure shown in Figure 1 of this annex the conformity of mass-produced headlamps shall not be contested if the deviation of the measured values of the headlamps in the unfavourable directions are:

2.1.1.1. sample A

A1:	one headlamp.....	0 %
	one headlamp not more than	20 %
A2:	both headlamps more than.....	0 %
	but not more than.....	20 %

go to sample B

2.1.1.2. sample B

B1:	both headlamps.....	0 %
-----	---------------------	-----

2.1.2. or if the conditions of paragraph 1.2.2. for sample A are fulfilled.

2.2. The conformity is contested

2.2.1. Following the sampling procedure shown in Figure 1 of this annex the conformity of mass-produced headlamps shall be contested and the manufacturer requested to make his production meet the requirements (alignment) if the deviations of the measured values of the headlamps are:

2.2.1.1. sample A

A3:	one headlamp not more than	20 %
	one headlamp more than	20 %
	but not more than	30 %

2.2.1.2. sample B

B2: in the case of A2

	one headlamp more than.....	0 %
	but not more than.....	20 %
	one headlamp not more than	20 %

B3: in the case of A2

	one headlamp.....	0 %
	one headlamp more than.....	20 %
	but not more than.....	30 %

2.2.2. or if the conditions of paragraph 1.2.2. for sample A are not fulfilled.

2.3. Approval withdrawn

Conformity shall be contested and paragraph 12 applied if, following the sampling procedure in Figure 1 of this annex, the deviations of the measured values of the headlamps are:

- 2.3.1. sample A
- A4: one headlamp not more than20 %
one headlamp more than.....30 %
 - A5: both headlamps more than.....20 %
- 2.3.2. sample B
- B4: in the case of A2
 - one headlamp more than.....0 %
 - but not more than.....20 %
 - one headlamp more than.....20 %
 - B5: in the case of A2
 - both headlamps more than.....20 %
 - B6: in the case of A2
 - one headlamp.....0 %
 - one headlamp more than.....30 %
- 2.3.3. or if the conditions of paragraph 1.2.2. for samples A and B are not fulfilled.
3. REPEATED SAMPLING
- In the cases of A3, B2, B3 a repeated sampling, third sample C of two headlamps and fourth sample D of two headlamps, selected from stock manufactured after alignment, is necessary within two months time after the notification.
- 3.1. The conformity is not contested
- Following the sampling procedure shown in Figure 1 of this annex the conformity of mass-produced headlamps shall not be contested if the deviations of the measured values of the headlamps are:
- 3.1.1.1. sample C
- C1: one headlamp.....0 %
one headlamp not more than20 %
 - C2: both headlamps more than.....0 %
but not more than.....20 %
- go to sample D
- 3.1.1.2. sample D
- D1: in the case of C2
 - both headlamps.....0 %
- 3.1.2. or if the conditions of paragraph 1.2.2. for sample C are fulfilled.
- 3.2. The conformity is contested
- 3.2.1. Following the sampling procedure shown in Figure 1 of this annex the conformity of mass-produced headlamps shall be contested and the manufacturer requested to

make his production meet the requirements (alignment) if the deviations of the measured values of the headlamps are:

3.2.1.1. sample D

D2: in the case of C2

- one headlamp more than.....0 %
- but not more than.....20 %
- one headlamp not more than20 %

3.2.1.2. or if the conditions of paragraph 1.2.2. for sample C are not fulfilled:

3.3. Approval withdrawn

Conformity shall be contested and paragraph 12 applied if, following the sampling procedure in Figure 1 of this annex, the deviations of the measured values of the headlamps are:

3.3.1. sample C

- C3: one headlamp not more than20 %
- one headlamp more than..... 20 %
- C4: both headlamps more than20 %

3.3.2. sample D

D3: in the case of C2

- one headlamp 0 or more than0 %
- one headlamp more than20 %

3.3.3. or if the conditions of paragraph 1.2.2. for samples C and D are not fulfilled.

4. CHANGE OF THE VERTICAL POSITION OF THE CUT-OFF LINE

With respect to the verification of the change in vertical positions of the cut-off line under the influence of heat, the following procedure shall be applied:

One of the headlamps of sample A after sampling procedure in Figure 1 of this annex shall be tested according to the procedure described in paragraph 2.1. of annex 6 after being subjected three consecutive times to the cycle described in paragraph 2.2.2. of annex 6.

The headlamp shall be considered as acceptable if Δr does not exceed 1.5 mrad.

If this value exceeds 1.5 mrad but is not more than 2.0 mrad, the second headlamp of sample A shall be subjected to the test after which the mean of the absolute values recorded in both samples shall not exceed 1.5 mrad.

However, if this value of 1.5 mrad on sample A is not complied with, the two headlamps of sample B shall be subjected to the same procedure and the value of Δr for each of them shall not exceed 1.5 mrad.

Figure 1

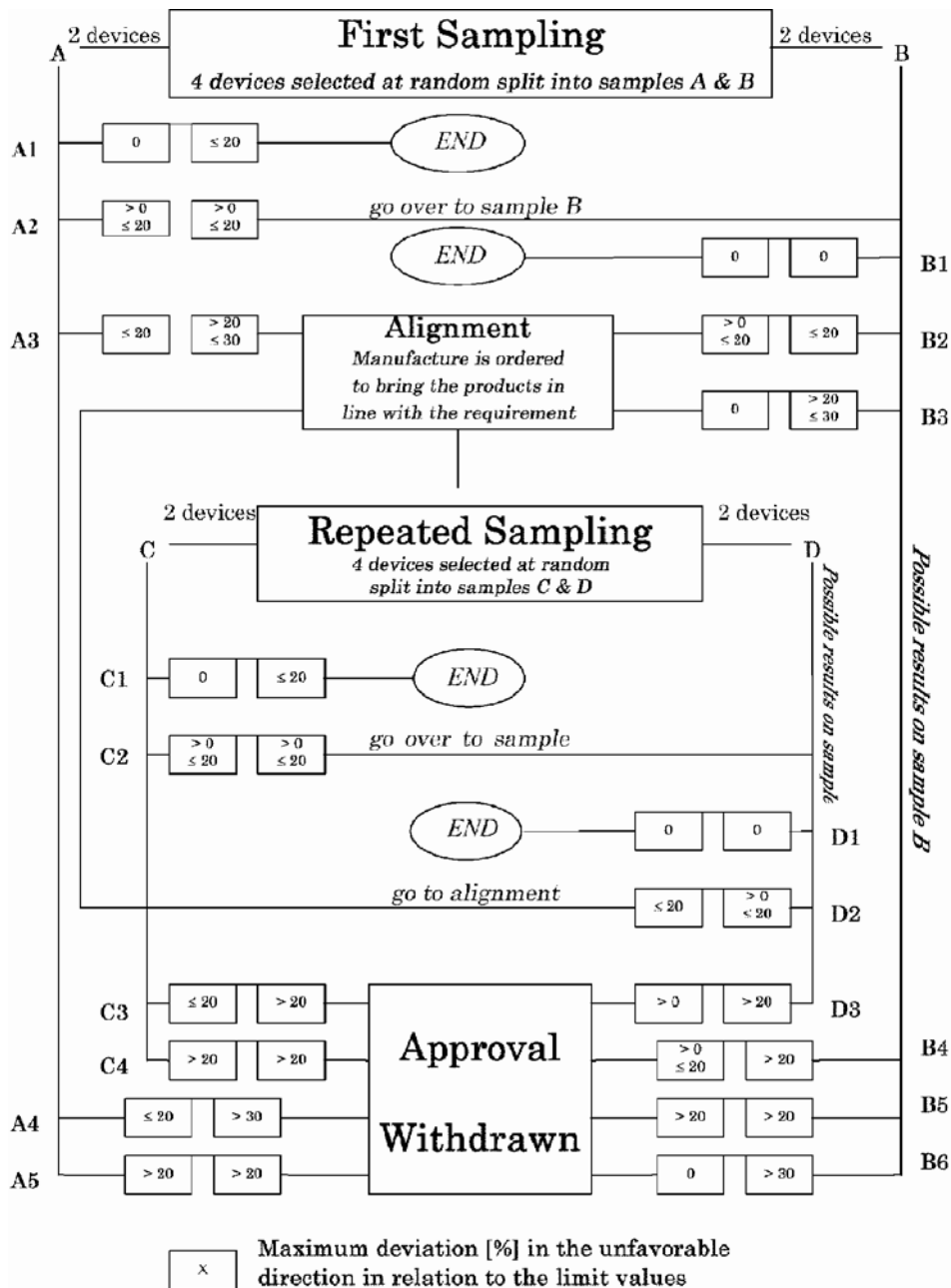

APPENDIX F
AGREEMENT

**CONCERNING THE ADOPTION OF UNIFORM TECHNICAL PRESCRIPTIONS
FOR WHEELED VEHICLES, EQUIPMENT AND PARTS WHICH CAN BE FITTED
AND/OR BE USED ON WHEELED VEHICLES AND THE CONDITIONS FOR
RECIPROCAL RECOGNITION OF APPROVALS GRANTED ON THE BASIS OF
THESE PRESCRIPTIONS ^{*/}**

(Revision 2, including the amendments which entered into force on 16 October 1995)

Addendum 111: Regulation No. 112

Revision 1

Incorporating all valid text up to :

Supplement 1 to the original version of the Regulation - Date of entry into force: 11 August 2002

Supplement 2 to the original version of the Regulation - Date of entry into force: 10 December 2002

Supplement 3 to the original version of the Regulation - Date of entry into force: 30 October 2003

Supplement 4 to the original version of the Regulation - Date of entry into force: 13 November 2004

Supplement 5 to the original version of the Regulation - Date of entry into force: 4 July 2006

Also incorporating amendments to Revision 2. All valid text up to: ^{1/}

Supplement 6 to the original version of the Regulation - Date of entry into force: 10 October 2006

Supplement 7 to the original version of the Regulation - Date of entry into force: 2 February 2007

Uniform provisions concerning the approval of motor vehicle headlamps emitting an asymmetrical passing beam or a driving beam or both and equipped with filament lamps



UNITED NATIONS

^{*/} Former title of the Agreement: Agreement Concerning the Adoption of Uniform Conditions of Approval and Reciprocal Recognition of Approval for Motor Vehicle Equipment and Parts, done at Geneva on 20 March 1958.

^{1/} Amendments compiled by Vehicle Safety Standards, Department of Transport and Regional Services

Regulation No. 112

UNIFORM PROVISIONS CONCERNING THE APPROVAL OF MOTOR VEHICLE
HEADLAMPS EMITTING AN ASYMMETRICAL PASSING BEAM OR A DRIVING
BEAM OR BOTH AND EQUIPPED WITH FILAMENT LAMPS

CONTENTS

REGULATION

A. ADMINISTRATIVE PROVISIONS

0. Scope

1. Definitions

2. Application for approval of a headlamp

3. Markings

4. Approval

B. TECHNICAL REQUIREMENTS FOR HEADLAMPS

5. General specifications

6. Illumination

7. Colour

8. Gauging of discomfort

C. FURTHER ADMINISTRATIVE PROVISIONS

9. Modification of the headlamp type and extension of approval

10. Conformity of production

11. Penalties for non-conformity of production

12. Production definitely discontinued

13. Names and addresses of Technical Services responsible for conducting approval tests,
and of Administrative Departments 22

ANNEXES

- Annex 1 - Communication concerning the approval or extension or refusal or withdrawal of approval or production definitely discontinued of a type of headlamp pursuant to Regulation No. 112

- Annex 2 - Examples of arrangement of approval marks

- Annex 3 - Measuring screen

- Annex 4 - Tests for stability of photometric performance of headlamps in operation
 - Appendix 1 - Overview of operational periods concerning tests for stability of photometric performance

- Annex 5 - Minimum requirements for conformity of production control procedures

- Annex 6 - Requirements for lamps incorporating lenses of plastic material - testing of lens or material samples and of complete lamps
 - Appendix 1 - Chronological order of approval tests
 - Appendix 2 - Method of measurement of the diffusion and transmission of light
 - Appendix 3 - Spray testing method
 - Appendix 4 - Adhesive tape adherence test

- Annex 7 - Minimum requirements for sampling by an inspector

- Annex 8 - Overview of operational periods concerning tests for stability of photometric performance

A. ADMINISTRATIVE PROVISIONS

0. SCOPE ^{1/}

This Regulation applies to headlamps for vehicles of categories L, M, N and T ².

1. DEFINITIONS

For the purpose of this Regulation,

- 1.1. "Lens" means the outermost component of the headlamp (unit) which transmits light through the illuminating surface;
- 1.2. "Coating" means any product or products applied in one or more layers to the outer face of a lens;
- 1.3. Headlamps of different "types" mean headlamps which differ in such essential respects as:
 - 1.3.1. the trade name or mark;
 - 1.3.2. the characteristics of the optical system;
 - 1.3.3. the inclusion or elimination of components capable of altering the optical effects by reflection, refraction, absorption and/or deformation during operation;
 - 1.3.4. suitability for right-hand or left-hand traffic or for both traffic systems;
 - 1.3.5. the kind of beam produced (passing beam, driving beam or both);
 - 1.3.6. the materials constituting the lenses and coating, if any;
 - 1.3.7. the category of filament lamp used.
- 1.4. Headlamps of different "Classes" (A or B) mean headlamps identified by particular photometric provisions.
- 1.5. The definitions given in Regulation No. 48 and its series of amendments in force at the time of application for type approval shall apply to this Regulation.

^{1/} Nothing in this Regulation shall prevent a Party to the Agreement applying this Regulation from prohibiting the combination of a headlamp incorporating a lens of plastic material approved under this Regulation with a mechanical headlamp-cleaning device (with wipers).

² As defined in Annex 7 to the Consolidated Resolution on the Construction of Vehicles (R.E.3), (document TRANS/WP.29/78/Rev.1/Amend.2 as last amended by Amend.4).

2. APPLICATION FOR APPROVAL OF A HEADLAMP
 - 2.1. The application for approval shall be submitted by the owner of the trade name or mark or by his duly accredited representative. It shall specify:
 - 2.1.1. whether the headlamp is intended to provide both a passing beam and a driving beam or only one of these beams;
 - 2.1.2. whether, if the headlamp is intended to provide a passing beam, it is designed for both left-hand and right-hand traffic or for either left-hand or right-hand traffic only;
 - 2.1.3. if the headlamp is equipped with an adjustable reflector, the mounting position(s) of the headlamp in relation to the ground and the longitudinal median plane of the vehicle;
 - 2.1.4. whether it concerns a Class A or B headlamp;
 - 2.1.5. the category of the filament lamp(s) used, as listed in Regulation No. 37.
 - 2.2. Every application for approval shall be accompanied by:
 - 2.2.1. drawings in triplicate in sufficient detail to permit identification of the type and representing a frontal view of the headlamp, with details of lens ribbing if any, and the cross-section; the drawings shall indicate the space reserved for the approval mark;
 - 2.2.1.1. if the headlamp is equipped with an adjustable reflector, an indication of the mounting position(s) of the headlamp in relation to the ground and the longitudinal median plane of the vehicle, if the headlamp is for use in that (those) position(s) only;
 - 2.2.2. a brief technical description including, in the case where headlamps are used to produce bend lighting, the extreme positions according to paragraph 6.2.9. below;
 - 2.2.3. two samples of the type of headlamp.
 - 2.2.4. For the test of plastic material of which the lenses are made:
 - 2.2.4.1. thirteen lenses;
 - 2.2.4.1.1. six of these lenses may be replaced by six samples of material at least 60 x 80 mm in size, having a flat or convex outer surface and a substantially flat area (radius of curvature not less than 300 mm) in the middle measuring at least 15 x 15 mm;

- 2.2.4.1.2. every such lens or sample of material shall be produced by the method to be used in mass production;
- 2.2.4.2. a reflector to which the lenses can be fitted in accordance with the manufacturer's instructions.
- 2.3. The materials making up the lenses and coatings, if any, shall be accompanied by the test report of the characteristics of these materials and coatings if they have already been tested.
3. MARKINGS ^{3/}
- 3.1. Headlamps submitted for approval shall bear the trade name or mark of the applicant.
- 3.2. They shall comprise, on the lens and on the main body, ^{4/} spaces of sufficient size for the approval mark and the additional symbols referred to in paragraph 4; these spaces shall be indicated on the drawings referred to in paragraph 2.2.1. above.
- 3.3. Headlamps designed to satisfy the requirements both of right-hand and of left-hand traffic shall bear markings indicating the two settings of the optical unit on the vehicle or of the filament lamp on the reflector; these markings shall consist of the letters "R/D" for the position for right-hand traffic and the letters "L/G" for the position for left-hand traffic.
4. APPROVAL
- 4.1. General
- 4.1.1. If all the samples of a type of headlamp submitted pursuant to paragraph 2 above satisfy the provisions of this Regulation, approval shall be granted.
- 4.1.2. Where grouped, combined or reciprocally incorporated lamps satisfy the requirements of more than one Regulation, a single international approval mark may be affixed provided that each of the grouped, combined or reciprocally incorporated lamps satisfies the provisions applicable to it.
- 4.1.3. An approval number shall be assigned to each type approved. Its first two digits (at present 00) shall indicate the series of amendments incorporating the most

^{3/} In the case of headlamps designed to meet the requirements of traffic moving on one side of the road only (either right or left), it is further recommended that the area which can be occulted to prevent discomfort to users in a country where traffic moves on the side of the road opposite to that of the country for which the headlamp was designed should be outlined indelibly on the front lens. This marking is not necessary, however, where the area is clearly apparent from the design.

^{4/} If the lens cannot be detached from the main body of the headlamp, a unique marking as per paragraph 4.2.5. shall be sufficient.

recent major technical amendments made to the Regulation at the time of issue of the approval. The same Contracting Party may not assign the same number to another type of headlamp covered by this Regulation.

4.1.4. Notice of approval or of extension or refusal or withdrawal of approval or production definitely discontinued of a type of headlamp pursuant to this Regulation shall be communicated to the Parties to the 1958 Agreement applying this Regulation, by means of a form conforming to the model in Annex 1 to this Regulation, with the indications according to paragraph 2.2.1.1.

4.1.4.1. if the headlamp is equipped with an adjustable reflector and if this headlamp is to be used only in mounting positions according to the indications in paragraph 2.2.1.1. the applicant shall be obliged by the Approval Authority to inform the user in a proper way about the correct mounting position(s).

4.1.5. In addition to the mark prescribed in paragraph 3.1., an approval mark as described in paragraphs 4.2. and 4.3. below shall be affixed in the spaces referred to in paragraph 3.2. above to every headlamp conforming to a type approved under this Regulation.

4.2. Composition of the approval mark

The approval mark shall consist of:

4.2.1. An international approval mark, comprising:

4.2.1.1. a circle surrounding the letter "E" followed by the distinguishing number of the country which has granted approval;^{5/}

4.2.1.2. the approval number prescribed in paragraph 4.1.3. above;

^{5/} 1 for Germany, 2 for France, 3 for Italy, 4 for the Netherlands, 5 for Sweden, 6 for Belgium, 7 for Hungary, 8 for the Czech Republic, 9 for Spain, 10 for Serbia, 11 for the United Kingdom, 12 for Austria, 13 for Luxembourg, 14 for Switzerland, 15 (vacant), 16 for Norway, 17 for Finland, 18 for Denmark, 19 for Romania, 20 for Poland, 21 for Portugal, 22 for the Russian Federation, 23 for Greece, 24 for Ireland, 25 for Croatia, 26 for Slovenia, 27 for Slovakia, 28 for Belarus, 29 for Estonia, 30 (vacant), 31 for Bosnia and Herzegovina, 32 for Latvia, 33 (vacant), 34 for Bulgaria, 35 (vacant), 36 for Lithuania, 37 for Turkey, 38 (vacant), 39 for Azerbaijan, 40 for The former Yugoslav Republic of Macedonia, 41 (vacant), 42 for the European Community (Approvals are granted by its Member States using their respective ECE symbol), 43 for Japan, 44 (vacant), 45 for Australia, 46 for Ukraine, 47 for South Africa, 48 for New Zealand, 49 for Cyprus, 50 for Malta, 51 for the Republic of Korea, 52 for Malaysia, 53 for Thailand, 54 and 55 (vacant) and 56 for Montenegro. Subsequent numbers shall be assigned to other countries in the chronological order in which they ratify or accede to the Agreement Concerning the Adoption of Uniform Technical Prescriptions for Wheeled Vehicles, Equipment and Parts which can be Fitted and/or be Used on Wheeled Vehicles and the Conditions for Reciprocal Recognition of Approvals Granted on the Basis of these Prescriptions, and the numbers thus assigned shall be communicated by the Secretary-General of the United Nations to the Contracting Parties to the Agreement.

- 4.2.2. the following additional symbol (or symbols):
- 4.2.2.1. on headlamps meeting left-hand traffic requirements only, a horizontal arrow pointing to the right of an observer facing the headlamp, i.e. to the side of the road on which the traffic moves;
 - 4.2.2.2. on headlamps designed to meet the requirements of both traffic systems by means of an appropriate adjustment of the setting of the optical unit or the filament lamp, a horizontal arrow with a head on each end, the heads pointing respectively to the left and to the right;
 - 4.2.2.3. on headlamps meeting the requirements of this Regulation in respect of the passing beam only, the letters "C" for Class A headlamp or "HC" for Class B headlamp;
 - 4.2.2.4. on headlamps meeting the requirements of this Regulation in respect of the driving beam only, the letters "R" for Class A headlamp or "HR" for Class B headlamp;
 - 4.2.2.5. on headlamps meeting the requirements of this Regulation in respect of both the passing beam and the driving beam, the letters "CR" for Class A headlamp or "HCR" for Class B headlamp;
 - 4.2.2.6. on headlamps incorporating a lens of plastic material, the group of letters "PL" to be affixed near the symbols prescribed in paragraphs 4.2.2.3. to 4.2.2.5. above;
 - 4.2.2.7. on headlamps meeting the requirements of this Regulation in respect of the driving beam, an indication of the maximum luminous intensity expressed by a reference mark, as defined in paragraph 6.3.2.1.2. below, placed near the circle surrounding the letter "E";

In the case of grouped or reciprocally incorporated driving beam headlamps, indication of the maximum luminous intensity of the driving beams as a whole shall be expressed as above.

- 4.2.3. In every case the relevant operating mode used during the test procedure according to paragraph 1.1.1.1. of Annex 4 and the permitted voltage(s) according to paragraph 1.1.1.2. of Annex 4 shall be stipulated on the approval forms and on the communication forms transmitted to the countries which are Contracting Parties to the Agreement and which apply this Regulation.

In the corresponding cases the device shall be marked as follows:

- 4.2.3.1. on headlamps meeting the requirements of this Regulation which are so designed that the filament of the passing beam shall not be lit simultaneously with that of any other lighting function with which it may be reciprocally incorporated: an oblique stroke (/) shall be placed behind the passing lamp symbol in the approval mark.

- 4.2.3.2. on headlamps meeting the requirements of Annex 4 to this Regulation only when supplied with a voltage of 6 V or 12 V, a symbol consisting of the number 24 crossed out by an oblique cross (x), shall be placed near the filament lamp holder.
- 4.2.4. The two digits of the approval number (at present 00) which indicate the series of amendments incorporating the most recent major technical amendments made to the Regulation at the time of issue of the approval and, if necessary, the required arrow may be marked close to the above additional symbols.
- 4.2.5. The marks and symbols referred to in paragraphs 4.2.1. to 4.2.3. above shall be clearly legible and be indelible. They may be placed on an inner or outer part (transparent or not) of the headlamp, which cannot be separated from the transparent part of the headlamp emitting the light. In any case they shall be visible when the headlamp is fitted on the vehicle or when a movable part such as the hood is opened.
- 4.3. Arrangement of the approval mark
- 4.3.1. Independent lamps
- Annex 2, figures 1 to 10, to this Regulation gives examples of arrangements of the approval mark with the above-mentioned additional symbols.
- 4.3.2. Grouped, combined or reciprocally incorporated lamps
- 4.3.2.1. Where grouped, combined or reciprocally incorporated lamps have been found to comply with the requirements of several Regulations, a single international approval mark may be affixed, consisting of a circle surrounding the letter "E" followed by the distinguishing number of the country which has granted the approval, and an approval number. This approval mark may be located anywhere on the grouped, combined or reciprocally incorporated lamps, provided that:
- 4.3.2.1.1. it is visible as per paragraph 4.2.5.;
- 4.3.2.1.2. no part of the grouped, combined or reciprocally incorporated lamps that transmits light can be removed without at the same time removing the approval mark.
- 4.3.2.2. The identification symbol for each lamp appropriate to each Regulation under which approval has been granted, together with the corresponding series of amendments incorporating the most recent major technical amendments to the Regulation at the time of issue of the approval, and if necessary, the required arrow shall be marked:
- 4.3.2.2.1. either on the appropriate light-emitting surface,

- 4.3.2.2.2. or in a group, in such a way that each of the grouped, combined or reciprocally incorporated lamps may be clearly identified (see four possible examples in Annex 2).
- 4.3.2.3. The size of the components of a single approval mark shall not be less than the minimum size required for the smallest of the individual marks by the Regulation under which approval has been granted.
- 4.3.2.4. An approval number shall be assigned to each type approved. The same Contracting Party may not assign the same number to another type of grouped, combined or reciprocally incorporated lamps covered by this Regulation.
- 4.3.2.5. Annex 2, figure 11, to this Regulation gives examples of arrangements of approval marks for grouped, combined or reciprocally incorporated lamps with all the above-mentioned additional symbols.

4.3.3. Lamps, the lens of which are used for different types of headlamps and which may be reciprocally incorporated or grouped with other lamps

The provisions laid down in paragraph 4.3.2. above are applicable.

- 4.3.3.1. In addition, where the same lens is used, the latter may bear the different approval marks relating to the different types of headlamps or units of lamps, provided that the main body of the headlamp, even if it cannot be separated from the lens, also comprises the space described in paragraph 3.2. above and bears the approval marks of the actual functions.

If different types of headlamps comprise the same main body, the latter may bear the different approval marks.

- 4.3.3.2. Annex 2, figure 12, to this Regulation gives examples of arrangements of approval marks relating to the above case.

B. TECHNICAL REQUIREMENTS FOR HEADLAMPS ^{6/}

5. GENERAL SPECIFICATIONS

- 5.1. Each sample shall conform to the specifications set forth in paragraphs 6 to 8 below.
- 5.2. Headlamps shall be so made as to retain their prescribed photometric characteristics and to remain in good working order when in normal use, in spite of the vibrations to which they may be subjected.
 - 5.2.1. Headlamps shall be fitted with a device enabling them to be so adjusted on the vehicles as to comply with the rules applicable to them. Such a device need not

^{6/} Technical requirements for filament lamps: see Regulation No. 37.

be fitted on units in which the reflector and the diffusing lens cannot be separated, provided the use of such units is confined to vehicles on which the headlamp setting can be adjusted by other means.

Where a headlamp providing a passing beam and a headlamp providing a driving beam, each equipped with its own filament lamp, are assembled to form a composite unit the adjusting device shall enable each optical system individually to be duly adjusted.

- 5.2.2. However, these provisions shall not apply to headlamp assemblies whose reflectors are indivisible. For this type of assembly the requirements of paragraph 6.3. of this Regulation apply.
- 5.3. The headlamp shall be equipped with filament lamp(s) approved according to Regulation No. 37. Any Regulation No. 37 filament lamp may be used, provided that no restriction on the application is made in the table of contents of Regulation No. 37.^{7/}
- 5.4. The components by which a filament lamp is fixed to the reflector shall be so made that, even in darkness, the filament lamp can be fixed in no position but the correct one.^{8/}
- 5.5. The filament lamp holder shall conform to the characteristics given in IEC Publication 61-2, third edition, 1969. The holder data sheet relevant to the category of filament lamp used, applies.
- 5.6. Headlamps designed to satisfy the requirements both of right-hand and of left-hand traffic may be adapted for traffic on a given side of the road either by an appropriate initial setting when fitted on the vehicle or by selective setting by the user. Such initial or selective setting may consist, for example, of fixing either the optical unit at a given angle on the vehicle or the filament lamp at a given angle in relation to the optical unit. In all cases, only two different and clearly distinct settings, one for right-hand and one for left-hand traffic, shall be possible, and the design shall preclude inadvertent shifting from one setting to the other or setting in an intermediate position. Where two different setting positions are provided for the filament lamp, the components for attaching the filament lamp to the reflector must be so designed and made that, in each of its two settings, the filament lamp will be held in position with the precision required for headlamps designed for traffic on only one side of the road. Conformity with the requirements of this paragraph shall be verified by visual

^{7/} HIR1 and/or H9 filament lamps shall only be permitted to produce passing beam in conjunction with the installation of headlamp cleaning device(s) conforming to Regulation No. 45. In addition, with respect to vertical inclination, the provision of paragraph 6.2.6.2.2. of Regulation No. 48, 01 series of amendments, shall not be applied when these lamps are installed.

This restriction shall apply as long as there is no general agreement on the use of levelling devices and headlamp cleaners with respect to the level of the performance of the headlamp.

^{8/} A headlamp is regarded as satisfying the requirements of this paragraph if the filament lamp can be easily fitted into the headlamp and the positioning lugs can be correctly fitted into their slots even in darkness.

inspection and, where necessary, by a test fitting.

- 5.7. Complementary tests shall be done according to the requirements of Annex 4 to ensure that in use there is no excessive change in photometric performance.
- 5.8. If the lens of the headlamp is of plastic material, tests shall be done according to the requirements of Annex 6.
- 5.9. On headlamps designed to provide alternately a driving beam and a passing beam, or a passing beam and/or a driving beam designed to become bend lighting, any mechanical, electromechanical or other device incorporated in the headlamp for these purposes shall be so constructed that:
 - 5.9.1. the device is strong enough to withstand 50,000 operations without suffering damage despite the vibrations to which it may be subjected in normal use;
 - 5.9.2. in the case of failure the illumination above the line H-H shall not exceed the values of a passing beam according to paragraph 6.2.5.; in addition, on headlamps designed to provide a passing and/or a driving beam to become a bend lighting, a minimum illumination of at least 5 lux shall be fulfilled in test point 25 V (VV line, D 75 cm).
 - 5.9.3. either the passing beam or the driving beam shall always be obtained without any possibility of the mechanism stopping in between two positions;
 - 5.9.4. the user cannot, with ordinary tools, change the shape or position of the moving parts.

6. ILLUMINATION

6.1. General provisions

- 6.1.1. Headlamps shall be so made that they give adequate illumination without dazzle when emitting the passing beam, and good illumination when emitting the driving beam.
- 6.1.2. The illumination produced by the headlamp shall be determined by means of a vertical screen set up 25 m forward of the headlamp and at right angles to its axes as shown in Annex 3 to this Regulation.
- 6.1.3. The headlamps shall be checked by means of an uncoloured standard (étalon) filament lamp designed for a rated voltage of 12 V. During the checking of the headlamp, the voltage at the terminals of the filament lamp shall be regulated so as to obtain the reference luminous flux as indicated at the relevant data sheet of Regulation No. 37.
- 6.1.4. The headlamp shall be considered acceptable if it meets the requirements of this paragraph 6 with at least one standard (étalon) filament lamp, which may be

submitted with the headlamp.

6.2. Provisions concerning passing beams

- 6.2.1. The passing beam must produce a sufficiently sharp "cut-off" to permit a satisfactory adjustment with its aid. The "cut-off" must be a horizontal straight line on the side opposite to the direction of the traffic for which the headlamp is intended; on the other side, it must not extend beyond either the broken line HV H₁ H₄ formed by a straight line HV H₁ making a 45° angle with the horizontal and the straight line H₁ H₄, 25 cm above the straight line hh, or the straight line HV H₃, inclined at an angle of 15° above the horizontal (see Annex 3). A cut-off extending beyond both line HV H₂ and line H₂ H₄ and resulting from a combination of the two above possibilities shall in no circumstances be permitted.
- 6.2.2. The headlamp shall be so aimed that:
- 6.2.2.1. in the case of headlamps designed to meet the requirements of right-hand traffic, the "cut-off" on the left-half of the screen ^{9/} is horizontal and, in the case of headlamps designed to meet the requirements of left-hand traffic, the "cut-off" on the right-half of the screen is horizontal;
- 6.2.2.2. this horizontal part of the "cut-off" is situated on the screen 25 cm below the level hh (see Annex 3);
- 6.2.2.3. the "elbow" of the "cut-off" is on line vv. ^{10/}
- 6.2.3. When so aimed, the headlamp need, if its approval is sought solely for provision of a passing beam, ^{11/} comply only with the requirements set out in paragraphs 6.2.5. to 6.2.7. and 6.2.9. below; if it is intended to provide both a passing beam and a driving beam, it shall comply with the requirements set out in paragraphs 6.2.5. to 6.2.7. and 6.3.
- 6.2.4. Where a headlamp so aimed does not meet the requirements set out in paragraphs 6.2.5. to 6.2.7. and 6.3., its alignment may be changed, provided that the axis of the beam is not displaced laterally by more than 1° (= 44 cm) to the right or left. ^{12/} To facilitate alignment by means of the "cut-off", the headlamp may be partially occulted in order to sharpen the "cut-off".

^{9/} The test screen must be sufficiently wide to allow examination of the "cut-off" over a range of at least 5° on either side of the line vv.

^{10/} If the beam does not have a cut-off with a clear "elbow", the lateral adjustment shall be effected in the manner which best satisfies the requirements for illumination at points 75 R and 50 R for right-hand traffic and for points 75 L and 50 L for left-hand traffic.

^{11/} Such a special "passing beam" headlamp may incorporate a driving beam not subject to requirements.

^{12/} The limit of realignment of 1° towards the right or left is not incompatible with upward or downward vertical realignment. The latter is limited only by the requirements of paragraph 6.3. However, the horizontal part of the "cut-off" should not extend beyond the line hh (the provisions of paragraph 6.3. are not applicable to headlamps intended to meet the requirements of this Regulation only for provision of a passing beam).

6.2.5. The illumination produced on the screen by the passing beam shall meet the following requirements:

Point on measuring screen		Required illumination in lux	
Headlamps for right-hand traffic	Headlamps for left-hand traffic	Class A headlamp	Class B headlamp
Point B 50 L	Point B 50 R	≤ 0.4	≤ 0.4
Point 75 R	Point 75 L	≥ 6	≥ 12
Point 75 L	Point 75 R	≤ 12	≤ 12
Point 50 L	Point 50 R	≤ 15	≤ 15
Point 50 R	Point 50 L	≥ 6	≥ 12
Point 50 V	Point 50 V	-	≥ 6
Point 25 L	Point 25 R	≥ 1.5	≥ 2
Point 25 R	Point 25 L	≥ 1.5	≥ 2
Any point in zone III		≤ 0.7	≤ 0.7
Any point in zone IV		≥ 2	≥ 3
Any point in zone I		≤ 20	$\leq 2E$ ^{*/}
*/ E is the actually measured value in points 50R respectively 50L			

6.2.6. There shall be no lateral variations detrimental to good visibility in any of the zones I, II, III and IV.

6.2.7. The illumination values in zones "A" and "B" as shown in figure C in Annex 3 shall be checked by the measurement of the photometric values of points 1 to 8 on this figure; these values shall lie within the following limits: ^{13/}

$$1 + 2 + 3 \geq 0.3 \text{ lux, and}$$

$$4 + 5 + 6 \geq 0.6 \text{ lux, and}$$

$$0.7 \text{ lux} \geq 7 \geq 0.1 \text{ lux and}$$

$$0.7 \text{ lux} \geq 8 \geq 0.2 \text{ lux}$$

6.2.8. Headlamps designed to meet the requirements of both right-hand and left-hand traffic must, in each of the two setting positions of the optical unit or of the filament lamp, meet the requirements set forth above for the corresponding direction of traffic.

^{13/} Illumination values in any point of zones A and B, which also lies within zone III, shall not exceed 0.7 lux.

- 6.2.9. The requirements in paragraph 6.2.5. above shall also apply to headlamps designed to provide bend lighting and/or that include the additional light source referred to in paragraph 6.2.10.2. In the case of a headlamp designed to provide bend lighting its alignment may be changed, provided that the axis of the beam is not displaced vertically by more than 0.2 °.
- 6.2.9.1. If bend lighting is obtained by:
- 6.2.9.1.1. swivelling the passing beam or moving horizontally the kink of the elbow of the cut-off, the measurements shall be carried out after the complete headlamp assembly has been reaimed horizontally, e.g. by means of a goniometer;
- 6.2.9.1.2. moving one or more optical parts of the headlamp without moving horizontally the kink of the elbow of the cut-off, measurements shall be carried out with these parts being in their extreme operating position;
- 6.2.9.1.3. means of one additional light source without moving horizontally the kink of the elbow of the cut-off, measurements shall be carried out with this light source activated.
- 6.2.10. Only one principal light source is permitted for each passing beam headlamp. However, a maximum of two additional light sources are permitted as follows:
- 6.2.10.1. One additional light source inside the passing beam headlamp according to Regulation No. 37 may be used to contribute to bend lighting.
- 6.2.10.2. One additional light source according to Regulation No. 37, inside the passing beam headlamp, may be used for the purposes of generating infrared radiation. It shall only be activated at the same time as the principal light source. In the event that the principal light source fails, this additional light source shall be automatically switched off.
- 6.2.10.3. In the event of failure of an additional light source, the headlamp shall continue to fulfil the requirements of the passing beam.
- 6.3. Provisions concerning driving beams
- 6.3.1. In the case of a headlamp designed to provide a driving beam and a passing beam, measurements of the illumination produced on the screen by the driving beam shall be taken with the same headlamp alignment as for measurements under paragraphs 6.2.5. to 6.2.7. above; in the case of a headlamp providing a driving beam only, it shall be so adjusted that the area of maximum illumination is centred on the point of intersection of lines hh and vv; such a headlamp need meet only the requirements referred to in paragraph 6.3.
- 6.3.2. It is possible to use several light sources for the driving beam.

- 6.3.3. The illumination produced on the screen by the driving beam shall meet the following requirements.
- 6.3.3.1. The point of intersection (HV) of lines hh and vv shall be situated within the isolux 80 per cent of maximum illumination. This maximum value (E_M) shall not be less than 32 lux for Class A headlamps and 48 lux for Class B headlamps. The maximum value shall in no circumstances exceed 240 lux; in addition, in the case of a combined passing and driving headlamp, this maximum value shall not be more than 16 times the illumination measured for the passing beam at point 75 R (or 75 L).

- 6.3.3.1.1. The maximum intensity (I_M) of the driving beam expressed in thousands of candelas shall be calculated by the formula:

$$I_M = 0.625 E_M$$

- 6.3.3.1.2. The reference mark (I'_M) of this maximum intensity, referred to in paragraph 4.2.2.7. above, shall be obtained by the ratio:

$$I'_M = \frac{I_M}{3} = 0.208 E_M$$

This value shall be rounded off to the value 7.5 - 10 - 12.5 - 17.5 - 20 - 25 - 27.5 - 30 - 37.5 - 40 - 45 - 50.

- 6.3.3.2. Starting from point HV, horizontally to the right and left, the illumination shall be not less than 16 lux for Class A headlamp and 24 lux for Class B headlamp up to a distance of 1.125 m and not less than 4 lux for Class A headlamp and 6 lux for Class B headlamp up to a distance of 2.25 m.

- 6.4. In the case of headlamps with adjustable reflector the requirements of paragraphs 6.2. and 6.3. are applicable for each mounting position indicated according to paragraph 2.1.3. For verification the following procedure shall be used:

- 6.4.1. Each applied position is realized on the test goniometer with respect to a line joining the centre of the light source and point HV on a aiming screen. The adjustable reflector is then moved into such a position that the light pattern on the screen corresponds to the aiming prescriptions of paragraphs 6.2.1. to 6.2.2.3. and/or 6.3.1;

- 6.4.2. with the reflector initially fixed according to paragraph 6.4.1., the headlamp must meet the relevant photometric requirements of paragraphs 6.2. and 6.3;

- 6.4.3. additional tests are made after the reflector has been moved vertically $\pm 2^\circ$ or at least into the maximum position, if less than 2° , from its initial position by means of the headlamps adjusting device. Having re-aimed the headlamp as a whole (by means of the goniometer for example) in the corresponding opposite

direction the light output in the following directions shall be controlled and lie within the required limits:

passing beam : points HV and 75 R (75 L respectively);
driving beam : E_M and point HV (percentage of E_M).

- 6.4.4. if the applicant has not indicated more than one mounting position, the procedure of paragraphs 6.4.1. to 6.4.3. shall be repeated for all other positions;
- 6.4.5. if the applicant has not asked for special mounting positions, the headlamp shall be aimed for measurements of paragraphs 6.2. and 6.3. with the headlamps adjusting device in its mean position. The additional test of paragraph 6.4.3. shall be made with the reflector moved into its extreme positions (instead of $\pm 2^\circ$) by means of the headlamps adjusting device.
- 6.5. The screen illumination values mentioned in paragraphs 6.2.5. to 6.2.7. and 6.3. above shall be measured by means of a photo receptor, the effective area of which shall be contained within a square of 65 mm side.

7. COLOUR

- 7.1. The colour of the light emitted shall be white. Expressed in CIE trichromatic coordinates, the light of the beams shall be in the following boundaries:

limit towards blue	:	$x \geq 0.310$
limit towards yellow	:	$x \leq 0.500$
limit towards green	:	$y \leq 0.150 + 0.640 x$
limit towards green	:	$y \leq 0.440$
limit towards purple	:	$y \geq 0.050 + 0.750 x$
limit towards red	:	$y \geq 0.382$

8. GAUGING OF DISCOMFORT

The discomfort caused by the passing beam of headlamps shall be gauged. 14/

C. FURTHER ADMINISTRATIVE PROVISIONS

9. MODIFICATION OF THE HEADLAMP TYPE AND EXTENSION OF APPROVAL

- 9.1. Every modification of the headlamp type shall be notified to the Administrative Department which approved the headlamp type. The said department may then either:
- 9.1.1. Consider that the modifications made are unlikely to have appreciable adverse effects and that in any event the headlamp still complies with the requirements;

14/ This requirement will be the subject of a recommendation to administrations.

or

- 9.1.2. Require a further test report from the Technical Service responsible for conducting the tests.
- 9.2. Confirmation or refusal of approval, specifying the alterations, shall be communicated by the procedure specified in paragraph 4.1.4. above to the Parties to the Agreement which apply this Regulation.
- 9.3. The Competent Authority issuing the extension of approval shall assign a series number to each communication form drawn up for such an extension and inform thereof the other Parties to the 1958 Agreement applying this Regulation by means of a communication form conforming to the model in Annex 1 to this Regulation.

10. CONFORMITY OF PRODUCTION

The conformity of production procedures shall comply with those set out in the Agreement, Appendix 2 (E/ECE/324-E/ECE/TRANS/505/Rev.2) with the following requirements:

- 10.1. Headlamps approved under this Regulation shall be so manufactured as to conform to the type approved by meeting the requirements set forth in paragraphs 6 and 7.
- 10.2. the minimum requirements for conformity of production control procedures set forth in Annex 5 to this Regulation shall be complied with.
- 10.3. The minimum requirements for sampling by an inspector set forth in Annex 7 to this Regulation shall be complied with.
- 10.4. The authority which has granted type approval may at any time verify the conformity control methods applied in each production facility. The normal frequency of these verifications shall be once every two years.
- 10.5. Headlamps with apparent defects are disregarded.
- 10.6. The reference mark is disregarded.

11. PENALTIES FOR NON-CONFORMITY OF PRODUCTION

- 11.1. The approval granted in respect of a type of headlamp pursuant to this Regulation may be withdrawn if the requirements are not complied with or if a headlamp bearing the approval mark does not conform to the type approved.
- 11.2. If a Contracting Party to the Agreement applying this Regulation withdraws an approval it has previously granted, it shall forthwith so notify the other

Contracting Parties applying this Regulation by means of a communication form conforming to the model in Annex 1 to this Regulation.

12. PRODUCTION DEFINITELY DISCONTINUED

If the holder of the approval completely ceases to manufacture a type of headlamp approved in accordance with this Regulation, he shall so inform the authority which granted the approval. Upon receiving the relevant communication, that authority shall inform thereof the other Parties to the 1958 Agreement applying this Regulation by means of a communication form conforming to the model in Annex 1 to this Regulation.

13. NAMES AND ADDRESSES OF TECHNICAL SERVICES RESPONSIBLE FOR CONDUCTING APPROVAL TESTS, AND OF ADMINISTRATIVE DEPARTMENTS

The Parties to the 1958 Agreement applying this Regulation shall communicate to the United Nations Secretariat the names and addresses of the Technical Services responsible for conducting approval tests and of the Administrative Departments which grant approval and to which forms certifying approval or extension or refusal or withdrawal of approval, or production definitely discontinued, issued in other countries, are to be sent.

Annex 1

COMMUNICATION

(maximum format: A4 (210 x 297 mm))

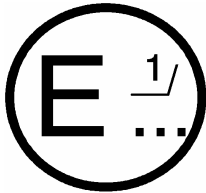

issued by: Name of administration:

.....
.....
.....

concerning: ^{2/} APPROVAL GRANTED
APPROVAL EXTENDED
APPROVAL REFUSED
APPROVAL WITHDRAWN
PRODUCTION DEFINITELY DISCONTINUED

of a type of headlamp pursuant to Regulation No. 112

Approval No.....

Extension No.

1. Trade name or mark of the device:
2. Manufacturer's name for the type of device:
3. Manufacturer's name and address:
4. If applicable, name and address of manufacturer's representative:
.....
5. Submitted for approval on:
6. Technical Service responsible for conducting approval tests:
.....
7. Date of report issued by that service:
8. Number of report issued by that service:
9. Brief description:
Category as described by the relevant marking: 3/
.....

- Number and category(ies) of filament lamp(s):
10. Approval mark position:
11. Reason(s) for extension of approval:
12. Approval granted/extended/refused//withdrawn 2/
13. Place:
14. Date:
15. Signature:

16. The list of documents deposited with the Administrative Service which has granted approval is annexed to this communication and may be obtained on request.

^{1/} Distinguishing number of the country which has granted/refused/withdrawn approval (see the provisions of the Regulation concerning approval).

^{2/} Strike out which does not apply.

^{3/} Indicate the appropriate marking selected from the list below:

C, \rightarrow C, \leftrightarrow C, R, R PL, CR, \rightarrow CR, \leftrightarrow CR, C/R, \rightarrow C/R, \leftrightarrow C/R, C/, \rightarrow C/, \leftrightarrow C/ ,
C PL, \rightarrow C PL, \leftrightarrow C PL, CR PL, \rightarrow CR PL, \leftrightarrow CR PL, C/R PL, \rightarrow C/R PL, \leftrightarrow C/R PL,
C/PL, \rightarrow C/PL, \leftrightarrow C/PL
HC, \rightarrow HC, \leftrightarrow HC, HR, HR PL, HCR, \rightarrow HCR, \leftrightarrow HCR, HC/R, \rightarrow HC/R, \leftrightarrow HC/R, HC/, \rightarrow HC/, \leftrightarrow HC/ ,
HC PL, \rightarrow HC PL, \leftrightarrow HC PL, HCR PL, \rightarrow HCR PL, \leftrightarrow HCR PL, HC/R PL, \rightarrow HC/R PL, \leftrightarrow HC/R PL,
HC/PL, \rightarrow HC/PL, \leftrightarrow HC/PL

Annex 2

EXAMPLES OF ARRANGEMENT OF APPROVAL MARKS

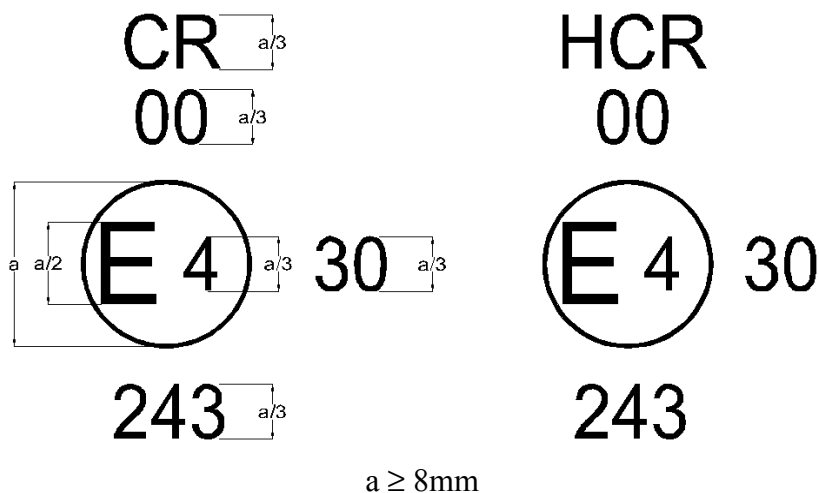

Figure 1

Figure 2

The headlamp bearing one of the above approval marks has been approved in the Netherlands (E 4) pursuant to Regulation No. 112 under approval number 243, meeting the requirements of this Regulation in its original form (00). The passing beam is designed for right-hand traffic only. The letters CR (Figure 1) indicate that it concerns a Class A passing and driving beam and the letters HCR (Figure 2) indicate that it concerns a Class B passing and driving beam.

The figure 30 indicates that the maximum luminous intensity of the driving beam is between 86250 and 101250 candelas.

Note: The approval number and additional symbols shall be placed close to the circle and either above or below the letter 'E', or to the right or left of that letter. The digits of the approval number shall be on the same side of the letter 'E' and face in the same direction.

The use of Roman numerals as approval numbers should be avoided so as to prevent any confusion with other symbols.

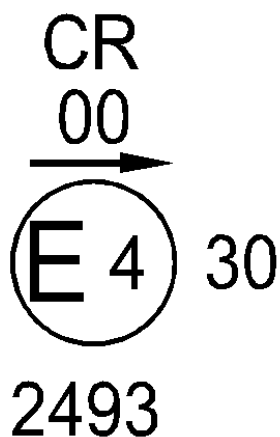

Figure 3

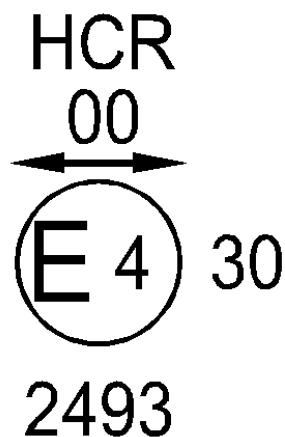

Figure 4a

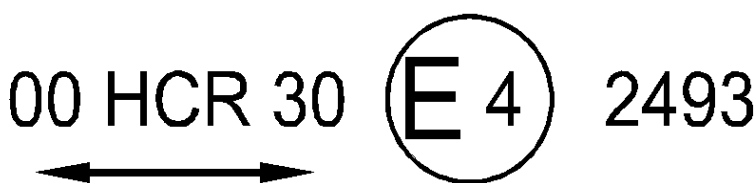

Figure 4b

The headlamp bearing the above approval mark meets the requirements of this Regulation in respect of both the passing beam and the driving beam and is designed:

Figure 3: Class A for left hand traffic only.

Figures 4a and 4b: Class B for both traffic systems by means of an appropriate adjustment of the setting of the optical unit or the filament lamp on the vehicle.

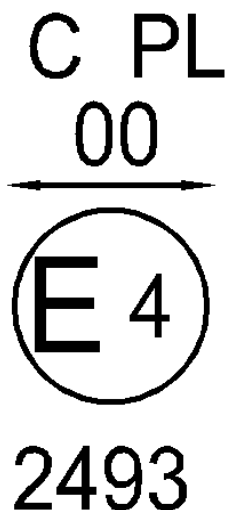

Figure 5

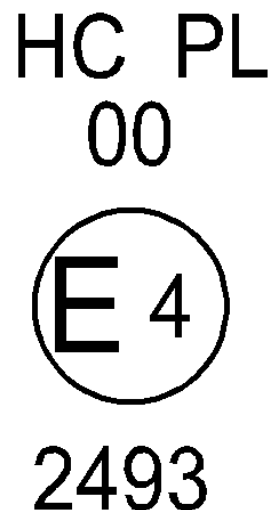
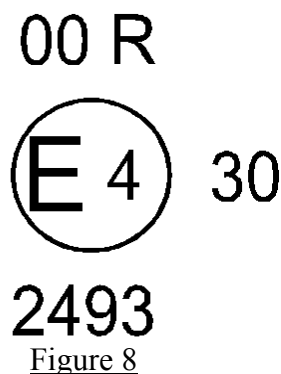
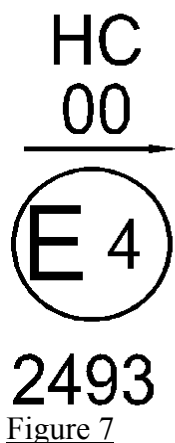

Figure 6

The headlamp bearing the above approval mark is a headlamp incorporating a lens of plastic material meeting the requirements of this Regulation in respect of the passing beam only and is designed:

Figure 5: Class A for both traffic systems.

Figure 6: Class B for right-hand traffic only.



The headlamp bearing the above approval mark is a headlamp meeting the requirements of this Regulation:

Figure 7: Class B in respect of the passing beam only and is designed for left-hand traffic only.

Figure 8: Class A in respect of the driving beam only.

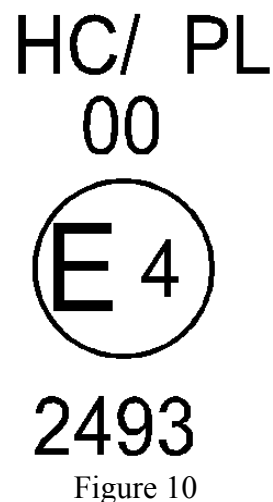
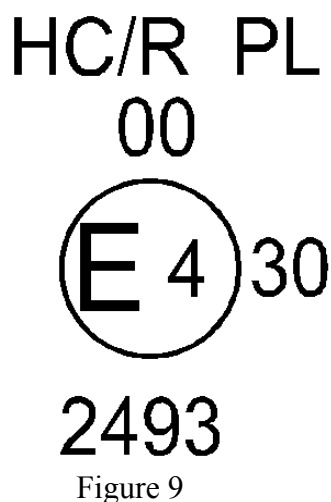

Identification of a headlamp incorporating a lens of plastic material meeting the requirements of this Regulation:

Figure 9: Class B in respect to both the passing beam and driving beam and designed for right-hand traffic only.

Figure 10: Class B in respect to the passing beam only and designed for right-hand traffic only.

The passing beam shall not be operated simultaneously with the driving beam and/or another reciprocally incorporated headlamp.

Simplified marking for grouped, combined or reciprocally incorporated lamps

Figure 11

(The vertical and horizontal lines schematize the shape of the light-signalling device. They are not part of the approval mark).

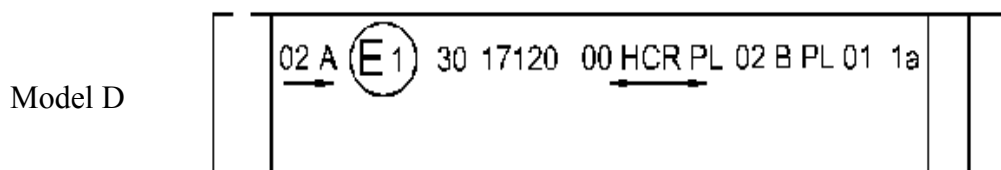
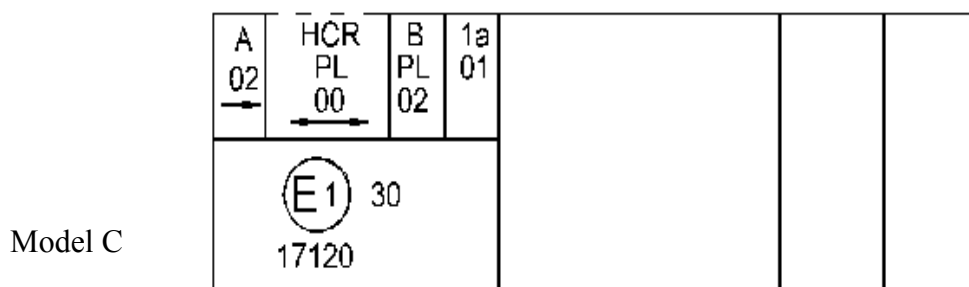
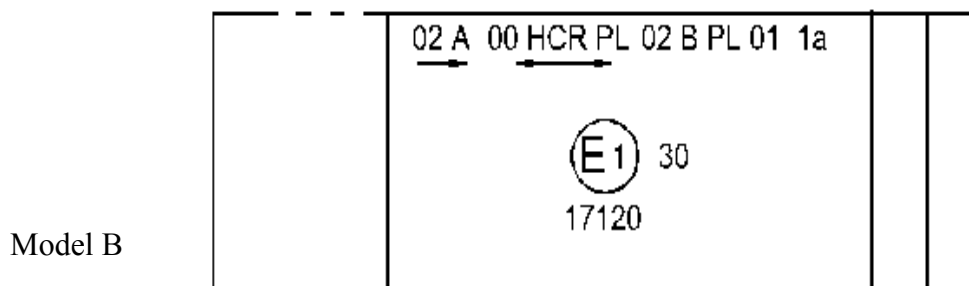
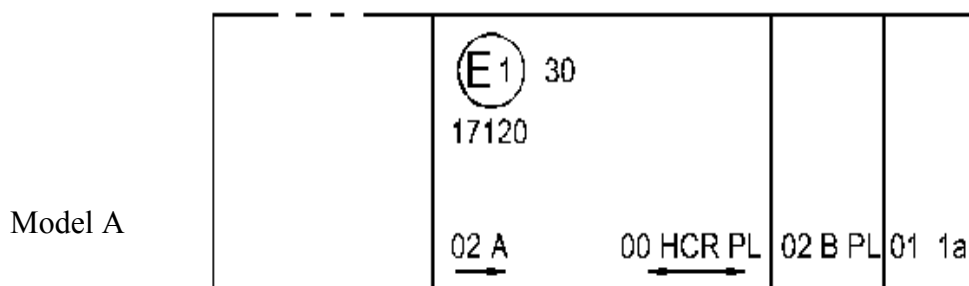

Note: The four examples above correspond to a lighting device bearing an approval mark comprising:

A front position lamp approved in accordance with the 02 series of amendments to Regulation No. 7,

A headlamp, Class B, with a passing beam designed for right- and left-hand traffic and a driving beam with a maximum intensity comprised between 86 250 and 101 250 candelas (as indicated by the number 30), approved in accordance with the requirements of this Regulation in its original form (00) and incorporating a lens of plastic material,

A front fog lamp approved in accordance with the 02 series of amendments to Regulation No. 19 and incorporating a lens of plastic material,

A front direction indicator lamp of category 1a approved in accordance with the 01 series of amendments to Regulation No. 6.

Figure 12

Lamp reciprocally incorporated with a headlamp

Example 1

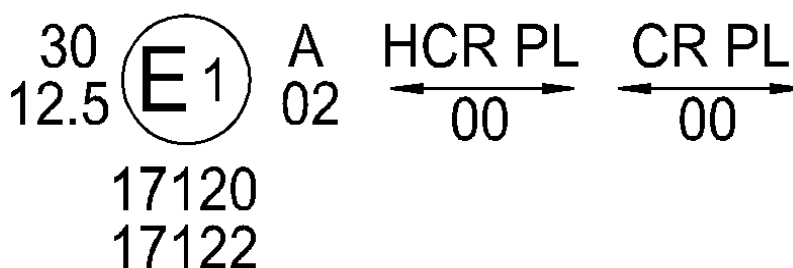

The above example corresponds to the marking of a lens of plastic material intended to be used in different types of headlamps, namely:

Either A headlamp, Class B, with a passing beam designed for both traffic systems and a driving beam with a maximum luminous intensity comprised between 86 250 and 101 250 candelas (as indicated by the number 30), approved in Germany (E1) in accordance with the requirements of this Regulation in its original form (00),

which is reciprocally incorporated with

A front position lamp approved in accordance with the 02 series of amendments to Regulation No. 7;

Or A headlamp, Class A, with a passing beam designed for both traffic systems and a driving beam with a maximum luminous intensity comprised between 33 750 cd and 45 000 cd (as indicated by the number 12.5), approved in Germany (E1) in accordance with the requirements of this Regulation in its original form (00),

which is reciprocally incorporated with

The same front position lamp as above;

Or even either of the above-mentioned-headlamps approved as a single lamp.

The main body of the headlamp shall bear the only valid approval number, for instance:

Example 2

00 HCR PL 20 00 HR PL 10
 ↔
 (E 2) 30
 81151

The above example corresponds to the marking of a lens of plastic material used in a unit of two headlamps approved in France (E2) under approval number 81151, consisting of:

A headlamp, Class B, emitting a passing beam and a driving beam with a maximum luminous intensity between x and y candelas, meeting the requirements of this Regulation, and

A headlamp, Class B, emitting a driving beam designed for both traffic systems with a maximum luminous intensity between w and z candelas, meeting the requirements of this Regulation, the maximum luminous intensities of the driving beams as a whole being comprised between 86 250 and 101 250 candelas.

Annex 3
MEASURING SCREEN

A. Headlamp for right-hand traffic
 (dimension in mm with screen at 25 m distance)

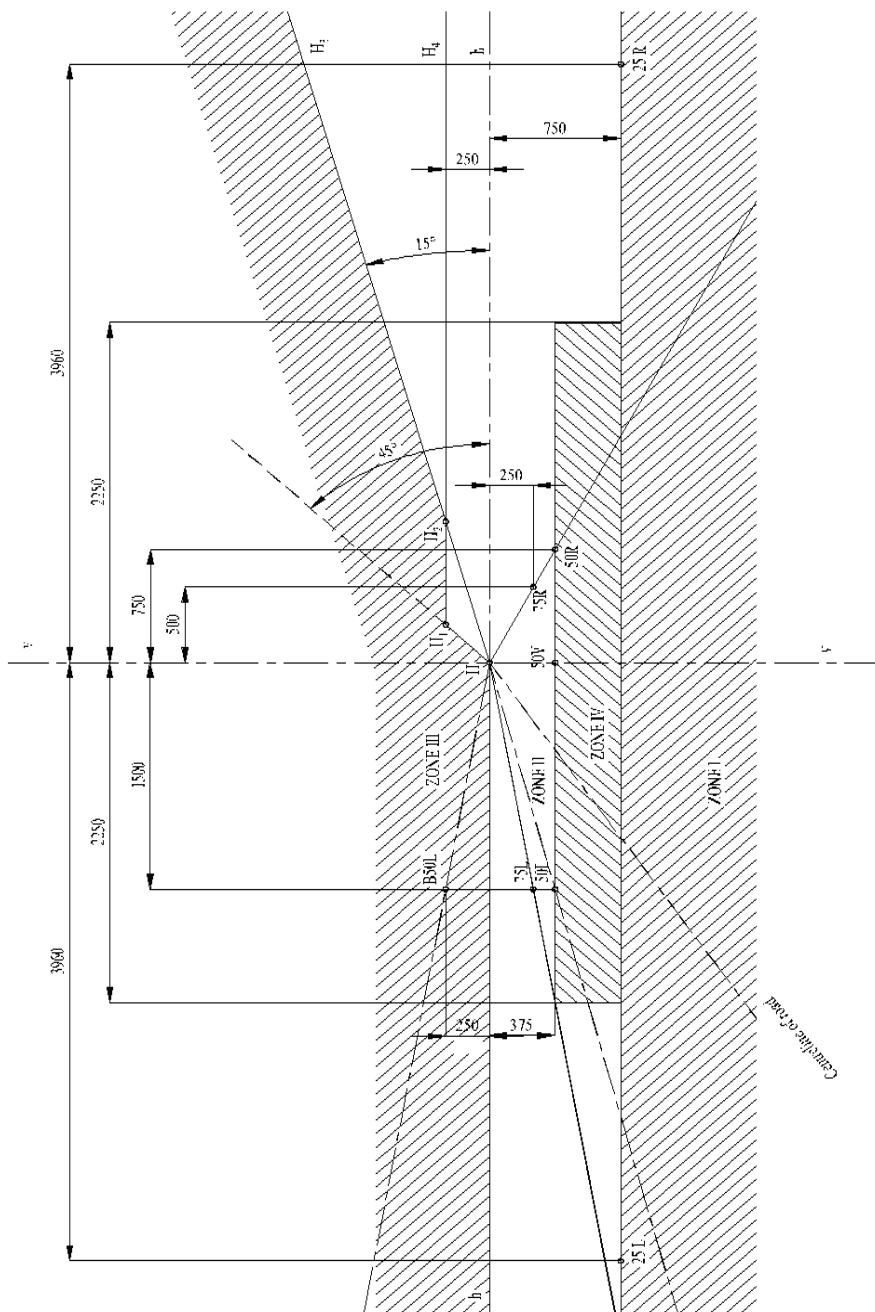

h-h : horizontal plane) passing through
 v-v : vertical plane) focus of headlamp

B. Headlamp for left-hand traffic
 (dimension in mm with screen at 25 m distance)

STANDARD EUROPEAN BEAM

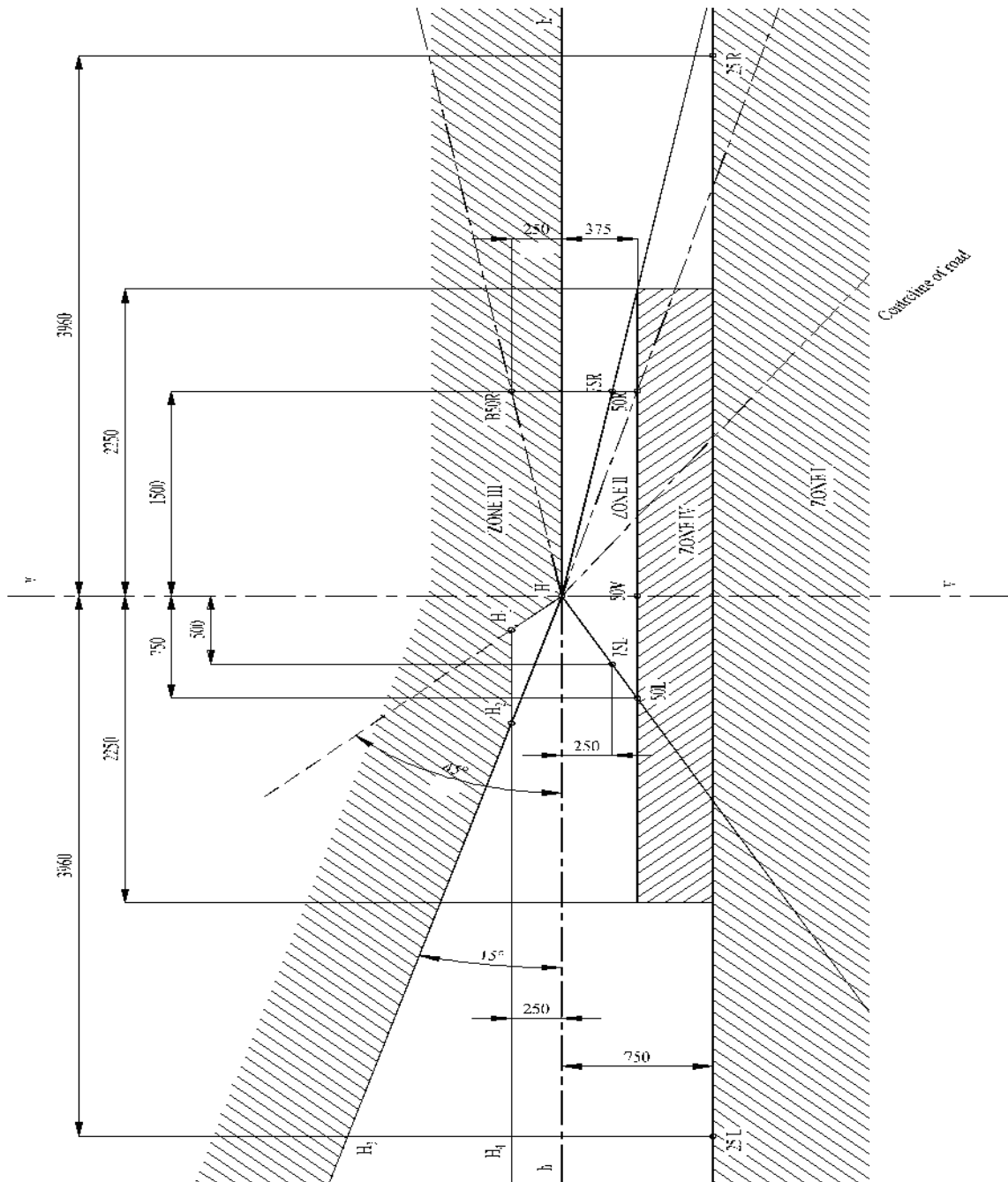

h-h : horizontal plane) passing through
 v-v : vertical plane) focus of headlamp

Figure C

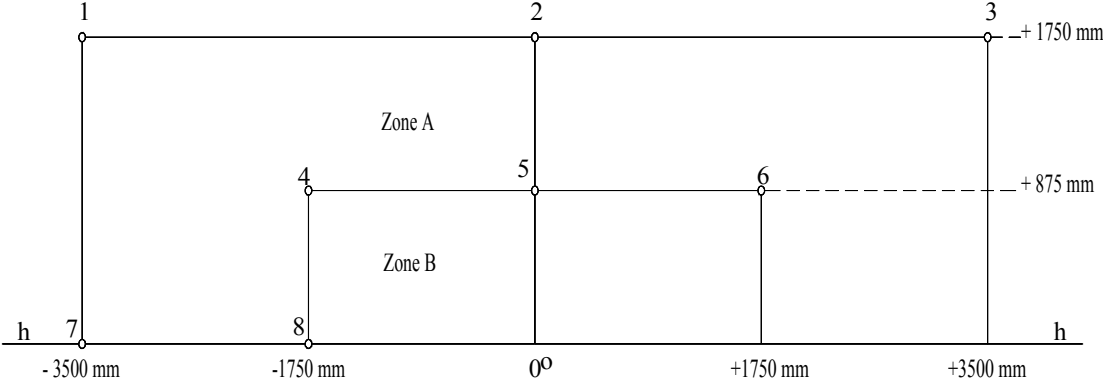

Note: Figure C shows the measuring points for right-hand traffic. Points 7 and 8 move to their corresponding location at the right-hand side of the picture for left-hand traffic.

Annex 4

TESTS FOR STABILITY OF PHOTOMETRIC PERFORMANCE OF HEADLAMPS IN OPERATION

TESTS ON COMPLETE HEADLAMPS

Once the photometric values have been measured according to the prescriptions of this Regulation, in the point for E_{\max} for driving beam and in points HV, 50 R, B 50 L for passing beam (or HV, 50 L, B 50 R for headlamps designed for left-hand traffic) a complete headlamp sample shall be tested for stability of photometric performance in operation. "Complete headlamp" shall be understood to mean the complete lamp itself including those surrounding body parts and lamps which could influence its thermal dissipation.

1. TEST FOR STABILITY OF PHOTOMETRIC PERFORMANCE

The tests shall be carried out in a dry and still atmosphere at an ambient temperature of $23^{\circ}\text{C} \pm 5^{\circ}\text{C}$, the complete headlamp being mounted on a base representing the correct installation on the vehicle.

1.1. Clean headlamp

The headlamp shall be operated for 12 hours as described in paragraph 1.1.1. and checked as prescribed in paragraph 1.1.2.

1.1.1. Test procedure^{1/}

The headlamp shall be operated for a period according to the specified time, so that:

- 1.1.1.1. (a) In the case where only one lighting function (driving or passing beam or front fog lamp) is to be approved, the corresponding filament is lit for the prescribed time,^{2/}
- (b) In the case of a headlamp with a passing beam and one or more driving beams or in case of a headlamp with a passing beam and a front fog lamp:
- (i) the headlamp shall be subjected to the following cycle until the time specified is reached:
15 minutes, passing-beam filament lit;
5 minutes, all filaments lit.

^{1/} For the test schedule see Annex 8 to this Regulation.

^{2/} When the tested headlamp includes signalling lamps, the latter shall be lit for the duration of the test. In the case of a direction indicator lamp, it shall be lit in flashing mode with an on/off time of approximately one to one.

- (ii) if the applicant declares that the headlamp is to be used with only the passing beam lit or only the driving beam(s) lit^{3/} at a time, the test shall be carried out in accordance with this condition, activating^{2/} successively the passing beam half of the time and the driving beam(s) (simultaneously) for half the time specified in paragraph 1.1. above.
- (c) in the case of a headlamp with a front fog lamp and one or more driving beams:
 - (i) the headlamp shall be subjected to the following cycle until the time specified is reached:
15 minutes, front fog lamp lit;
5 minutes, all filaments lit.
 - (ii) if the applicant declares that the headlamp is to be used with only the front fog lamp lit or only the driving beam(s) lit^{3/} at a time, the test shall be carried out in accordance with this condition, activating^{2/} successively the front fog lamp half of the time and the driving beam(s) (simultaneously) for half the time specified in paragraph 1.1. above.
- (d) In the case of headlamp with a passing beam, one or more driving beams and a front fog lamp:
 - (i) the headlamp shall be subjected to the following cycle until the time specified is reached:
15 minutes, passing-beam filament lit;
5 minutes, all filaments lit.
 - (ii) if the applicant declares that the headlamp is to be used with only the passing beam lit or only the driving beam(s)^{3/} lit at a time, the test shall be carried out in accordance with this condition, activating^{2/} successively the passing beam half of the time and the driving beam(s) for half the time specified in paragraph 1.1. above, while the front fog lamp is subjected to a cycle of 15 minutes off and 5 minutes lit for half of the time and during the operation of the driving beam;
 - (iii) if the applicant declares that the headlamp is to be used with only the passing beam lit or only the front fog lamp^{3/} lit at a time, the test shall be carried out in accordance with this condition, activating^{2/} successively the passing beam half of the time and the front fog lamp for half of the time specified in paragraph 1.1. above, while

^{3/} Should two or more lamp filaments be simultaneously lit when headlamp flashing is used, this shall not be considered as being normal use of the filaments simultaneously.

the driving beam(s) is(are) subjected to a cycle of 15 minutes off and 5 minutes lit for half of the time and during the operation of the passing beam;

(iv) if the applicant declares that the headlamp is to be used with only the passing beam lit or only the driving beam(s)^{3/} lit or only the front fog lamp^{3/} lit at a time, the test shall be carried out in accordance with this condition, activating^{2/} successively the passing beam one third of the time, the driving beam(s) one third of the time and the front fog lamp for one third of the time specified in paragraph 1.1. above.

(e) In the case of a passing beam designed to provide bend lighting with the addition of a light source, this light source shall be switched on for 1 minute, and switched off for 9 minutes during the activation of the passing beam only (see Annex 4 - Appendix 1).

1.1.1.2. Test voltage

The voltage shall be adjusted so as to supply 90 per cent of the maximum wattage specified in Regulation No. 37 for the filament lamp(s) used.

The applied wattage shall in all cases comply with the corresponding value of a filament lamp of 12 V rated voltage, except if the applicant for approval specifies that the headlamp may be used at a different voltage. In the latter case, the test shall be carried out with the filament lamp whose wattage is the highest that can be used.

1.1.2. Test results

1.1.2.1. Visual inspection

Once the headlamp has been stabilized to the ambient temperature, the headlamp lens and the external lens, if any, shall be cleaned with a clean, damp cotton cloth. It shall then be inspected visually; no distortion, deformation, cracking or change in colour of either the headlamp lens or the external lens, if any, shall be noticeable.

1.1.2.2. Photometric test

To comply with the requirements of this Regulation, the photometric values shall be verified in the following points:

Passing beam:

50 R - B 50 L - HV for headlamps designed for right-hand traffic,
50 L - B 50 R - HV for headlamps designed for left-hand traffic.

Driving beam: Point of E_{\max}

Another aiming may be carried out to allow for any deformation of the headlamp base due to heat (the change of the position of the cut-off line is covered in paragraph 2 of this annex).

A 10 per cent discrepancy between the photometric characteristics and the values measured prior to the test is permissible including the tolerances of the photometric procedure.

1.2. Dirty headlamp

After being tested as specified in paragraph 1.1. above, the headlamp shall be operated for one hour as described in paragraph 1.1.1., after being prepared as prescribed in paragraph 1.2.1., and checked as prescribed in paragraph 1.1.2.

1.2.1. Preparations of the headlamp

1.2.1.1. Test mixture

1.2.1.1.1. For headlamp with the outside lens in glass:

The mixture of water and a polluting agent to be applied to the headlamp shall be composed of:

9 parts by weight of silica sand with a particle size of 0-100 μm ,

1 part by weight of vegetal carbon dust (beechwood) with a particle size of 0-100 μm ,

0.2 parts by weight of NaCMC ^{4/}, and

an appropriate quantity of distilled water, with a conductivity of ≤ 1 mS/m.

The mixture must not be more than 14 days old.

1.2.1.1.2. For headlamp with outside lens in plastic material:

The mixture of water and polluting agent to be applied to the headlamp shall be composed of:

9 parts by weight of silica sand with a particle size of 0-100 μm ,

^{4/} NaCMC represents the sodium salt of carboxymethylcellulose, customarily referred to as CMC. The NaCMC used in the dirt mixture shall have a degree of substitution (DS) of 0.6-0.7 and a viscosity of 200-300 cP for a 2 per cent solution at 20° C.

1 part by weight of vegetal carbon dust (beechwood) with a particle size of 0-100 μm ,

0.2 part by weight of NaCMC ^{4/},

13 parts by weight of distilled water with a conductivity of ≤ 1 mS/m, and

2 ± 1 parts by weight of surface-actant ^{5/}

The mixture must not be more than 14 days old.

1.2.1.2. Application of the test mixture to the headlamp

The test mixture shall be uniformly applied to the entire light-emitting surface of the headlamp and then left to dry. This procedure shall be repeated until the illumination value has dropped to 15-20 per cent of the values measured for each following point under the conditions described in this annex:

Point of E_{max} in passing beam/driving beam and in driving beam only,

50 R and 50 V ^{6/} for a passing lamp only, designed for right-hand traffic,

50 L and 50 V ^{6/} for a passing lamp only, designed for left-hand traffic.

1.2.1.3. Measuring equipment

The measuring equipment shall be equivalent to that used during headlamp approval tests. A standard (étalon) filament lamp shall be used for the photometric verification.

2. TEST FOR CHANGE IN VERTICAL POSITION OF THE CUT-OFF LINE UNDER THE INFLUENCE OF HEAT

This test consists of verifying that the vertical drift of the cut-off line under the influence of heat does not exceed a specified value for an operating passing lamp.

The headlamp tested in accordance with paragraph 1, shall be subjected to the test described in paragraph 2.1., without being removed from or readjusted in relation to its test fixture.

^{5/} The tolerance on quantity is due to the necessity of obtaining a dirt that correctly spreads out on all the plastic lens.

^{6/} Point 50 V is situated 375 mm below HV on the vertical line v-v on the screen at 25 m distance.

2.1. Test

The test shall be carried out in a dry and still atmosphere at an ambient temperature of $23^{\circ}\text{C} \pm 5^{\circ}\text{C}$.

Using a mass production filament lamp, which has been aged for at least one hour the headlamp shall be operated on passing beam without being dismantled from or readjusted in relation to its test fixture. (For the purpose of this test, the voltage shall be adjusted as specified in paragraph 1.1.1.2.). The position of the cut-off line in its horizontal part (between vv and the vertical line passing through point B 50 L for right-hand traffic or B 50 R for left-hand traffic) shall be verified 3 minutes (r_3) and 60 minutes (r_{60}) respectively after operation.

The measurement of the variation in the cut-off line position as described above shall be carried out by any method giving acceptable accuracy and reproducible results.

2.2. Test results

2.2.1. The result in milliradians (mrad) shall be considered as acceptable for a passing lamp, only when the absolute value $\Delta r_I = |r_3 - r_{60}|$ recorded on the headlamp is not more than 1.0 mrad ($\Delta r_I \leq 1.0 \text{ mrad}$).

2.2.2. However, if this value is more than 1.0 mrad but not more than 1.5 mrad ($1.0 \text{ mrad} < \Delta r_I \leq 1.5 \text{ mrad}$) a second headlamp shall be tested as described in paragraph 2.1. after being subjected three consecutive times to the cycle as described below, in order to stabilize the position of mechanical parts of the headlamp on a base representative of the correct installation on the vehicle:

Operation of the passing beam for one hour, (the voltage shall be adjusted as specified in paragraph 1.1.1.2.),

Period of rest for one hour.

The headlamp type shall be considered as acceptable if the mean value of the absolute values Δr_I measured on the first sample and Δr_{II} measured on the second sample is not more than 1.0 mrad.

$$\left(\frac{\Delta r_I + \Delta r_{II}}{2} \leq 1 \text{ mrad} \right)$$

Annex 4 - Appendix 1

OVERVIEW OF OPERATIONAL PERIODS CONCERNING TESTS FOR STABILITY OF PHOTOMETRIC PERFORMANCE

- Abbreviations:
- P: passing beam lamp
 - D: driving beam lamp (D₁ + D₂ means two driving beams)
 - F: front fog lamp
 - - - - means a cycle of 15 minutes off and 5 minutes lit.
 - means a cycle of 9 minutes off and 1 minutes lit

All following grouped headlamps and front fog lamps together with the added marking symbols are given as examples and are not exhaustive.

1. P or D or F (HC or HR or B)

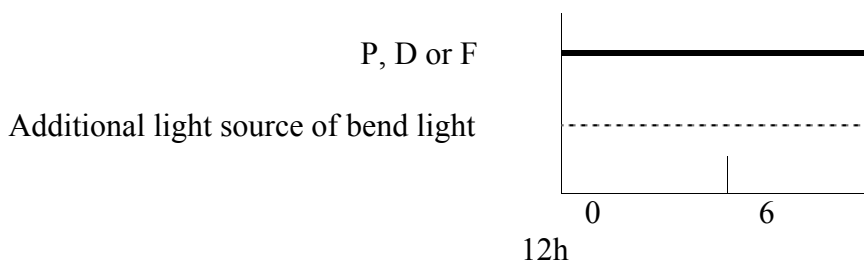

2. P+F (HC B) or P+D (HCR)

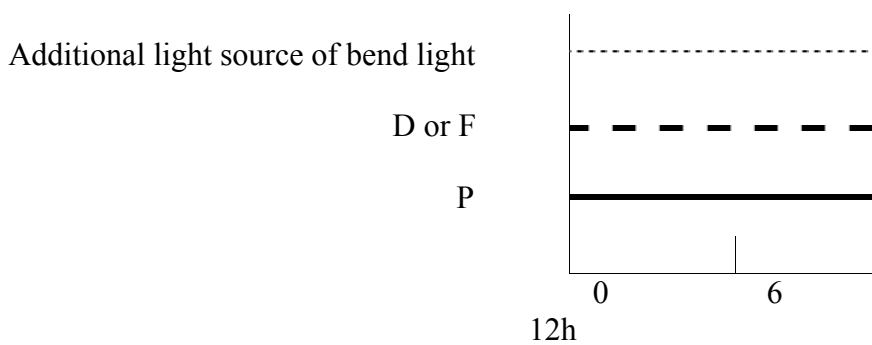

3. P+F (HC B/) or HC/B or P+D (HC/R)

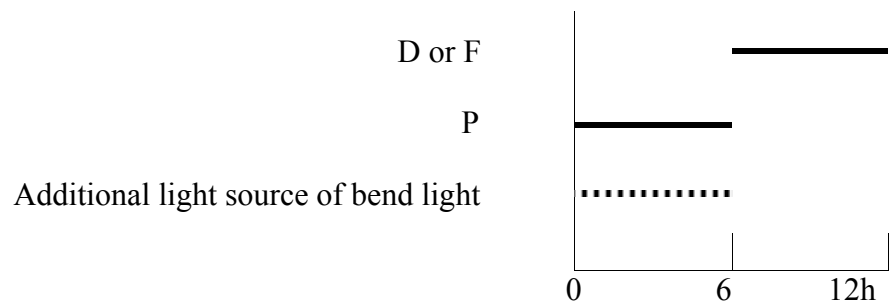

Annex 5

MINIMUM REQUIREMENTS FOR CONFORMITY OF PRODUCTION CONTROL PROCEDURES

1. GENERAL
 - 1.1. The conformity requirements shall be considered satisfied from a mechanical and a geometrical standpoint, if the differences do not exceed inevitable manufacturing deviations within the requirements of this Regulation. This condition also applies to colour.
 - 1.2. With respect to photometric performances, the conformity of mass-produced headlamps shall not be contested if, when testing photometric performances of any headlamp chosen at random and equipped with a standard (étalon) filament lamp:
 - 1.2.1. no measured value deviates unfavourably by more than 20 per cent from the value prescribed in this Regulation. For values B 50 L (or R) and zone III, the maximum unfavourable deviation may be respectively:

B 50 L (or R):	0.2 lx equivalent 20 per cent
	0.3 lx equivalent 30 per cent
Zone III	0.3 lx equivalent 20 per cent
	0.45 lx equivalent 30 per cent
 - 1.2.2. or if
 - 1.2.2.1. for the passing beam, the values prescribed in this Regulation are met at HV (with a tolerance of + 0.2 lx) and related to that aiming at least one point of each area delimited on the measuring screen (at 25 m) by a circle 15 cm in radius around points B 50 L (or R)^{1/} (with a tolerance of + 0.1 lx), 75 R (or L), 50 V, 25 R, 25 L, and in the entire area of zone IV which is not more than 22.5 cm above line 25 R and 25 L;
 - 1.2.2.2. and if, for the driving beam, HV being situated within the isolux 0.75 E_{max}, a tolerance of + 20 per cent for maximum values and -20 per cent for minimum values is observed for the photometric values at any measuring point specified in paragraph 6.3.2. of this Regulation.
 - 1.2.3. If the results of the test described above do not meet the requirements, the alignment of the headlamp may be changed, provided that the axis of the beam is not displaced laterally by more than 1° to the right or left.^{2/}

^{1/} Letters in brackets refer to headlamps intended for left-hand traffic.

^{2/} See footnote 11/ in the text of this Regulation.

1.2.4. If the results of the tests described above do not meet the requirements, tests shall be repeated using another standard (étalon) filament lamp.

1.3. With respect to the verification of the change in vertical position of the cut-off line under the influence of heat, the following procedure shall be applied:

One of the sampled headlamps shall be tested according to the procedure described in paragraph 2.1. of Annex 4 after being subjected three consecutive times to the cycle described in paragraph 2.2.2. of Annex 4.

The headlamp shall be considered as acceptable if Δr does not exceed 1.5 mrad.

If this value exceeds 1.5 mrad but is not more than 2.0 mrad, a second sample shall be subjected to the test after which the mean of the absolute values recorded on both samples shall not exceed 1.5 mrad.

2. MINIMUM REQUIREMENTS FOR VERIFICATION OF CONFORMITY BY THE MANUFACTURER

For each type of headlamp the holder of the approval mark shall carry out at least the following tests, at appropriate intervals. The tests shall be carried out in accordance with the provision of this Regulation.

If any sampling shows non-conformity with regard to the type of test concerned, further samples shall be taken and tested. The manufacturer shall take steps to ensure the conformity of the production concerned.

2.1. Nature of tests

Tests of conformity in this Regulation shall cover the photometric characteristics and the verification of the change in vertical position of the cut-off line under the influence of heat.

2.2. Methods used in tests

2.2.1. Tests shall generally be carried out in accordance with the methods set out in this Regulation.

2.2.2. In any test of conformity carried out by the manufacturer, equivalent methods may be used with the consent of the Competent Authority responsible for approval tests. The manufacturer is responsible for proving that the applied methods are equivalent to those laid down in this Regulation.

2.2.3. The application of paragraphs 2.2.1. and 2.2.2. requires regular calibration of test apparatus and its correlation with measurement made by a Competent Authority.

2.2.4. In all cases the reference methods shall be those of this Regulation, particular for the purpose of administrative verification and sampling.

2.3. Nature of sampling

Samples of headlamps shall be selected at random from the production of a uniform batch. A uniform batch means a set of headlamps of the same type, defined according to the production methods of the manufacturer.

The assessment shall, in general, cover series production from individual factories. However, a manufacturer may group together records concerning the same type from several factories provided these operate under the same quality system and quality management.

2.4. Measured and recorded photometric characteristics

The sampled headlamps shall be subjected to photometric measurements at the points provided for in the Regulation, the reading being limited at the points E_{\max} , HV^{3/}, HL, HR^{4/} in the case of a driving beam, and to points B 50 L (or R), HV, 50 V, 75 R (or L) and 25 L (or R) in the case of the passing beam (see figure in Annex 3).

2.5. Criteria governing acceptability

The manufacturer is responsible for carrying out a statistical study of the test results and for defining, in agreement with the Competent Authority, criteria governing acceptability of his products in order to meet the specification laid down for verification of conformity of products in paragraph 10.1. of this Regulation.

The criteria governing acceptability shall be such that, with a confidence level of 95 per cent, the minimum probability of passing a spot check in accordance with Annex 7 (first sampling) would be 0.95.

^{3/} When the driving beam is reciprocally incorporated with the passing beam, HV in the case of the driving beam shall be the same measuring point as in the case of the passing beam.

^{4/} HL and HR: points "hh" located at 1.125 m to the left and to the right of point HV respectively.

Annex 6REQUIREMENTS FOR LAMPS INCORPORATING LENSES OF PLASTIC MATERIAL -
TESTING OF LENS OR MATERIAL SAMPLES AND OF COMPLETE LAMPS

1. GENERAL SPECIFICATIONS

- 1.1. The samples supplied pursuant to paragraph 2.2.4. of this Regulation shall satisfy the specifications indicated in paragraphs 2.1. to 2.5. below.
- 1.2. The two samples of complete lamps supplied pursuant to paragraph 2.2.3. of this Regulation and incorporating lenses of plastic material shall, with regard to the lens material, satisfy the specifications indicated in paragraph 2.6. below.
- 1.3. The samples of lenses of plastic material or samples of material shall be subjected, with the reflector to which they are intended to be fitted (where applicable), to approval tests in the chronological order indicated in table A reproduced in Appendix 1 to this annex.
- 1.4. However, if the lamp manufacturer can prove that the product has already passed the tests prescribed in paragraphs 2.1. to 2.5. below, or the equivalent tests pursuant to another regulation, those tests need not be repeated; only the tests prescribed in Appendix 1, table B, shall be mandatory.

2. TESTS

2.1. Resistance to temperature changes2.1.1. Tests

Three new samples (lenses) shall be subjected to five cycles of temperature and humidity (RH = relative humidity) change in accordance with the following programme:

3 hours at $40^{\circ}\text{C} \pm 2^{\circ}\text{C}$ and 85-95 per cent RH;

1 hour at $23^{\circ}\text{C} \pm 5^{\circ}\text{C}$ and 60-75 per cent RH;

15 hours at $-30^{\circ}\text{C} \pm 2^{\circ}\text{C}$;

1 hour at $23^{\circ}\text{C} \pm 5^{\circ}\text{C}$ and 60-75 per cent RH;

3 hours at $80^{\circ}\text{C} \pm 2^{\circ}\text{C}$;

1 hour at $23^{\circ}\text{C} \pm 5^{\circ}\text{C}$ and 60-75 per cent RH;

Before this test, the samples shall be kept at $23^{\circ}\text{C} \pm 5^{\circ}\text{C}$ and 60-75 per cent RH for at least four hours.

Note: The periods of one hour at $23^{\circ}\text{C} \pm 5^{\circ}\text{C}$ shall include the periods of transition from one temperature to another which are needed in order to avoid thermal shock effects.

2.1.2. Photometric measurements

2.1.2.1. Method

Photometric measurements shall be carried out on the samples before and after the test.

These measurements shall be made using a standard (étalon) lamp, at the following points:

B 50 L and 50 R for the passing beam of a passing lamp or a passing/driving lamp (B 50 R and 50 L in the case of headlamps intended for left-hand traffic);

E_{max} route for the driving beam of a driving lamp or a passing/driving lamp.

2.1.2.2. Results

The variation between the photometric values measured on each sample before and after the test shall not exceed 10 per cent including the tolerances of the photometric procedure.

2.2. Resistance to atmospheric and chemical agents

2.2.1. Resistance to atmospheric agents

Three new samples (lenses or samples of material) shall be exposed to radiation from a source having a spectral energy distribution similar to that of a black body at a temperature between 5,500 K and 6,000 K. Appropriate filters shall be placed between the source and the samples so as to reduce as far as possible radiations with wave lengths smaller than 295 nm and greater than 2,500 nm. The samples shall be exposed to an energetic illumination of $1,200\text{ W/m}^2 \pm 200\text{ W/m}^2$ for a period such that the luminous energy that they receive is equal to $4,500\text{ MJ/m}^2 \pm 200\text{ MJ/m}^2$. Within the enclosure, the temperature measured on the black panel placed on a level with the samples shall be $50^{\circ}\text{C} \pm 5^{\circ}\text{C}$. In order to ensure a regular exposure, the samples shall revolve around the source of radiation at a speed between 1 and 5 1/min.

The samples shall be sprayed with distilled water of conductivity lower than 1 mS/m at a temperature of $23^{\circ}\text{C} \pm 5^{\circ}\text{C}$, in accordance with the following cycle:

spraying: 5 minutes; drying: 25 minutes.

2.2.2. Resistance to chemical agents

After the test described in paragraph 2.2.1. above and the measurement described in paragraph 2.2.3.1. below have been carried out, the outer face of the said three samples shall be treated as described in paragraph 2.2.2.2. with the mixture defined in paragraph 2.2.2.1. below.

2.2.2.1. Test mixture

The test mixture shall be composed of 61.5 per cent n-heptane, 12.5 per cent toluene, 7.5 per cent ethyl tetrachloride, 12.5 per cent trichloroethylene and 6 per cent xylene (volume per cent).

2.2.2.2. Application of the test mixture

Soak a piece of cotton cloth (as per ISO 105) until saturation with the mixture defined in paragraph 2.2.2.1. above and, within 10 seconds, apply it for 10 minutes to the outer face of the sample at a pressure of 50 N/cm², corresponding to an effort of 100 N applied on a test surface of 14 x 14 mm.

During this 10-minute period, the cloth pad shall be soaked again with the mixture so that the composition of the liquid applied is continuously identical with that of the test mixture prescribed.

During the period of application, it is permissible to compensate the pressure applied to the sample in order to prevent it from causing cracks.

2.2.2.3. Cleaning

At the end of the application of the test mixture, the samples shall be dried in the open air and then washed with the solution described in paragraph 2.3.

(Resistance to detergents)

23°C ± 5°C.

Afterwards the samples shall be carefully rinsed with distilled water containing not more than 0.2 per cent impurities at 23°C ± 5°C and then wiped off with a soft cloth.

2.2.3. Results

2.2.3.1. After the test of resistance to atmospheric agents, the outer face of the samples shall be free from cracks, scratches, chipping and deformation, and the mean

variation in transmission $\Delta t = \frac{T_2 - T_3}{T_2}$, measured on the three samples according

to the procedure described in Appendix 2 to this annex shall not exceed 0.020 ($\Delta t_m \leq 0.020$).

- 2.2.3.2. After the test of resistance to chemical agents, the samples shall not bear any traces of chemical staining likely to cause a variation of flux diffusion, whose mean variation $\Delta d = \frac{T_5 - T_4}{T_2}$, measured on the three samples according to the procedure described in Appendix 2 to this annex shall not exceed 0.020 ($\Delta d_m \leq 0.020$).

2.3. Resistance to detergents and hydrocarbons

2.3.1. Resistance to detergents

The outer face of three samples (lenses or samples of material) shall be heated to $50^\circ\text{C} \pm 5^\circ\text{C}$ and then immersed for five minutes in a mixture maintained at $23^\circ\text{C} \pm 5^\circ\text{C}$ and composed of 99 parts distilled water containing not more than 0.02 per cent impurities and one part alkylaryl sulphonate.

At the end of the test, the samples shall be dried at $50^\circ\text{C} \pm 5^\circ\text{C}$.

The surface of the samples shall be cleaned with a moist cloth.

2.3.2. Resistance to hydrocarbons

The outer face of these three samples shall then be lightly rubbed for one minute with a cotton cloth soaked in a mixture composed of 70 per cent n-heptane and 30 per cent toluene (volume per cent), and shall then be dried in the open air.

2.3.3. Results

After the above two tests have been performed successively, the mean value of the variation in transmission $\Delta t = \frac{T_2 - T_3}{T_2}$, measured on the three samples according to

the procedure described in Appendix 2 to this annex shall not exceed 0.010 ($\Delta t_m \leq 0.010$).

2.4. Resistance to mechanical deterioration

2.4.1. Mechanical deterioration method

The outer face of the three new samples (lenses) shall be subjected to the uniform mechanical deterioration test by the method described in Appendix 3 to this annex.

2.4.2. Results

After this test, the variations:

in transmission:
$$\Delta t = \frac{T_2 - T_3}{T_2},$$

and in diffusion:
$$\Delta t = \frac{T_5 - T_4}{T_2},$$

shall be measured according to the procedure described in Appendix 2 in the area specified in paragraph 2.2.4.1.1. of this Regulation. The mean value of the three samples shall be such that:

$$\Delta t_m \leq 0.100;$$

$$\Delta d_m \leq 0.050.$$

2.5. Test of adherence of coatings, if any2.5.1. Preparation of the sample

A surface of 20 mm x 20 mm in area of the coating of a lens shall be cut with a razor blade or a needle into a grid of squares approximately 2 mm x 2 mm. The pressure on the blade or needle shall be sufficient to cut at least the coating.

2.5.2. Description of the test

Use an adhesive tape with a force adhesion of 2 N/(cm of width) \pm 20 per cent measured under the standardized conditions specified in Appendix 4 to this annex. This adhesive tape, which shall be at least 25 mm wide, shall be pressed for at least five minutes to the surface prepared as prescribed in paragraph 2.5.1.

Then the end of the adhesive tape shall be loaded in such a way that the force of adhesion to the surface considered is balanced by a force perpendicular to that surface. At this stage, the tape shall be torn off at a constant speed of 1.5 m/s \pm 0.2 m/s.

2.5.3. Results

There shall be no appreciable impairment of the gridded area. Impairments at the intersections between squares or at the edges of the cuts shall be permitted, provided that the impaired area does not exceed 15 per cent of the gridded surface.

2.6. Tests of the complete headlamp incorporating a lens of plastic material

2.6.1. Resistance to mechanical deterioration of the lens surface

2.6.1.1. Tests

The lens of lamp sample No. 1 shall be subjected to the test described in paragraph 2.4.1. above.

2.6.1.2. Results

After the test, the results of photometric measurements carried out on the headlamp in accordance with this Regulation shall not exceed by more than 30 per cent the maximum values prescribed at points B 50 L and HV and not be more than 10 per cent below the minimum values prescribed at point 75 R (in the case of headlamps intended for left-hand traffic, the points to be considered are B 50 R, HV and 75 L).

2.6.2. Test of adherence of coatings, if any

The lens of lamp sample No. 2 shall be subjected to the test described in paragraph 2.5. above.

3. VERIFICATION OF THE CONFORMITY OF PRODUCTION

3.1. With regard to the materials used for the manufacture of lenses, the lamps of a series shall be recognized as complying with this Regulation if:

3.1.1. After the test for resistance to chemical agents and the test for resistance to detergents and hydrocarbons, the outer face of the samples exhibits no cracks, chipping or deformation visible to the naked eye (see paras. 2.2.2., 2.3.1. and 2.3.2.);

3.1.2. After the test described in paragraph 2.6.1.1., the photometric values at the points of measurement considered in paragraph 2.6.1.2. are within the limits prescribed for conformity of production by this Regulation.

3.2. If the test results fail to satisfy the requirements, the tests shall be repeated on another sample of headlamps selected at random.

Annex 6 - Appendix 1

CHRONOLOGICAL ORDER OF APPROVAL TESTS

A. Tests on plastic materials (lenses or samples of material supplied pursuant to paragraph 2.2.4. of this Regulation).

Samples	Lenses or samples of material										Lenses		
	1	2	3	4	5	6	7	8	9	10	11	12	13
Tests													
1.1. Limited photometry (A.6, para. 2.1.2.)										X	X	X	
1.1.1. Temperature change (A.6, para. 2.1.1.)										X	X	X	
1.1.2. Limited photometry (A.6, para. 2.1.2.)										X	X	X	
1.2.1. Transmission measurement	X	X	X	X	X	X	X	X	X				
1.2.2. Diffusion measurement	X	X	X				X	X	X				
1.3. Atmospheric agents (A.6, para. 2.2.1.)	X	X	X										
1.3.1. Transmission measurement	X	X	X										
1.4. Chemical agents (A.6, para.2.2.2.)	X	X	X										
1.4.1. Diffusion measurement	X	X	X										
1.5. Detergents (A.6, para. 2.3.1.)				X	X	X							
1.6. Hydrocarbons (A. 6, para. 2.3.2.)				X	X	X							
1.6.1. Transmission measurement				X	X	X							
1.7. Deterioration (A.6, para. 2.4.1.)							X	X	X				
1.7.1. Transmission measurement							X	X	X				
1.7.2. Diffusion measurement							X	X	X				
1.8. Adherence (A.6, para. 2.5.)													X

B. Tests on complete headlamps (supplied pursuant to paragraph 2.2.3. of this Regulation).

Tests	Complete headlamp	
	Sample No.	
	1	2
2.1. Deterioration (para. 2.6.1.1.)	x	
2.2. Photometry (para. 2.6.1.2.)	x	
2.3. Adherence (para. 2.6.2.)		x

Annex 6 - Appendix 2

METHOD OF MEASUREMENT OF THE DIFFUSION AND TRANSMISSION OF LIGHT

1. EQUIPMENT (see figure)

The beam of a collimator K with a half divergence $\beta/2 = 17.4 \times 10^4$ rd is limited by a diaphragm D_τ with an opening of 6 mm against which the sample stand is placed.

A convergent achromatic lens L_2 , corrected for spherical aberrations links the diaphragm D_τ with the receiver R; the diameter of the lens L_2 shall be such that it does not diaphragm the light diffused by the sample in a cone with a half top angle of $\beta/2 = 14^\circ$.

An annular diaphragm D_D , with angles $\alpha_0/2 = 1^\circ$ and $\alpha_{max}/2 = 12^\circ$ is placed in an image focal plane of the lens L_2 .

The non-transparent central part of the diaphragm is necessary in order to eliminate the light arriving directly from the light source. It shall be possible to remove the central part of the diaphragm from the light beam in such a manner that it returns exactly to its original position.

The distance $L_2 D_\tau$ and the focal length $F_2^{1/}$ of the lens L_2 shall be so chosen that the image of D_τ completely covers the receiver R.

When the initial incident flux is referred to 1,000 units, the absolute precision of each reading shall be better than 1 unit.

2. MEASUREMENTS

The following readings shall be taken:

Reading	With sample	With central part of D_D	Quantity represented
T_1	no	no	Incident flux in initial reading
T_2	yes (before test)	no	Flux transmitted by the new material in a field of 24°
T_3	yes (after test)	no	Flux transmitted by the tested material in a field of 24°
T_4	yes (before test)	yes	Flux diffused by the new material
T_5	yes (after test)	yes	Flux diffused by the tested material

^{1/} For L_2 it is recommended to use a focal distance of about 80 mm.

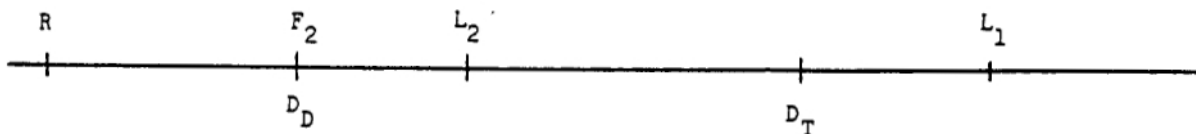
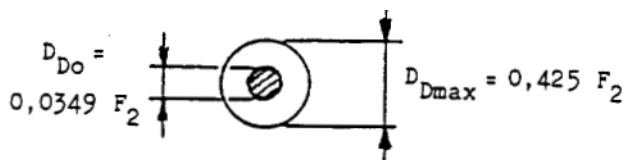
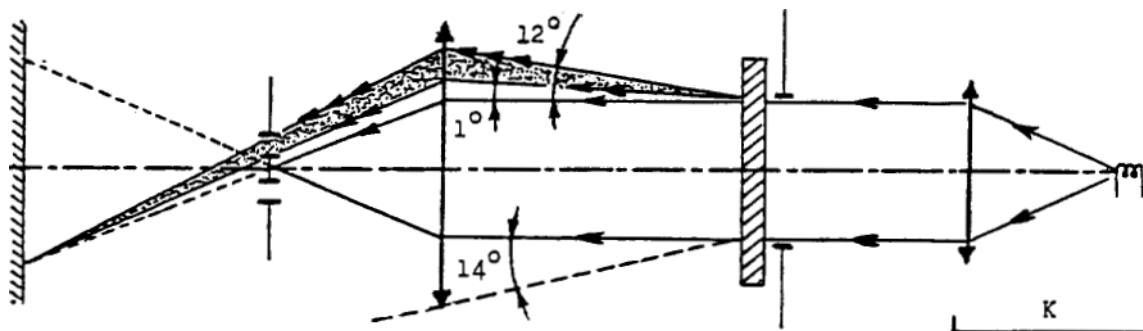

Annex 6 - Appendix 3

SPRAY TESTING METHOD

1. Test equipment

1.1. Spray gun

The spray gun used shall be equipped with a nozzle 1.3 mm in diameter allowing a liquid flow rate of 0.24 ± 0.02 l/minute at an operating pressure of 6.0 bars -0/+0.5 bar.

Under these operation conditions the fan pattern obtained shall be 170 mm 50 mm in diameter on the surface exposed to deterioration, at a distance of 380 mm 10 mm from the nozzle.

1.2. Test mixture

The test mixture shall be composed of:

Silica sand of hardness 7 on the Mohr scale, with a grain size between 0 and 0.2 mm and an almost normal distribution, with an angular factor of 1.8 to 2;

Water of hardness not exceeding 205 g/m^3 for a mixture comprising 25 g of sand per litre of water.

2. Test

The outer surface of the lamp lenses shall be subjected once or more than once to the action of the sand jet produced as described above. The jet shall be sprayed almost perpendicular to the surface to be tested.

The deterioration shall be checked by means of one or more samples of glass placed as a reference near the lenses to be tested. The mixture shall be sprayed until the variation in the diffusion of light on the sample or samples measured by the method described in Appendix 2, is such that:

$$\Delta d = \frac{T_5 - T_4}{T_2} = 0.0250 \pm 0.0025$$

Several reference samples may be used to check that the whole surface to be tested has deteriorated homogeneously.

Annex 6 - Appendix 4

ADHESIVE TAPE ADHERENCE TEST

1. PURPOSE

This method allows to determine under standard conditions the linear force of adhesion of an adhesive tape to a glass plate.

2. PRINCIPLE

Measurement of the force necessary to unstick an adhesive tape from a glass plate at an angle of 90°.

3. SPECIFIED ATMOSPHERIC CONDITIONS

The ambient conditions shall be at $23^{\circ}\text{C} \pm 5^{\circ}\text{C}$ and 65 ± 15 per cent RH.

4. TEST PIECES

Before the test, the sample roll of adhesive tape shall be conditioned for 24 hours in the specified atmosphere (see para. 3 above).

Five test pieces each 400 mm long shall be tested from each roll. These test pieces shall be taken from the roll after the first three turns were discarded.

5. PROCEDURE

The test shall be under the ambient conditions specified in paragraph 3.

Take the five test pieces while unrolling the tape radially at a speed of approximately 300 mm/s, then apply them within 15 seconds in the following manner:

Apply the tape to the glass plate progressively with a slight length-wise rubbing movement of the finger, without excessive pressure, in such a manner as to leave no air bubble between the tape and the glass plate.

Leave the assembly in the specified atmospheric conditions for 10 minutes.

Unstick about 25 mm of the test piece from the plate in a plane perpendicular to the axis of the test piece.

Fix the plate and fold back the free end of the tape at 90°. Apply force in such a manner that the separation line between the tape and the plate is perpendicular to this force and perpendicular to the plate.

Pull to unstick at a speed of 300 mm/s \pm 30 mm/s and record the force required.

6. RESULTS

The five values obtained shall be arranged in order and the median value taken as a result of the measurement. This value shall be expressed in Newtons per centimetre of width of the tape.

Annex 7

MINIMUM REQUIREMENTS FOR SAMPLING BY AN INSPECTOR

1. GENERAL

1.1. The conformity requirements shall be considered satisfied from a mechanical and a geometrical standpoint in accordance with the requirements of this Regulation, if any, if the differences do not exceed inevitable manufacturing deviations. This condition also applies to colour.

1.2. With respect to photometric performances, the conformity of mass-produced headlamps shall not be contested if, when testing photometric performances of any headlamp chosen at random and equipped with a standard filament lamp:

1.2.1. no measured value deviates unfavourably by more than 20 per cent from the value prescribed in this Regulation. For values B 50 L (or R) and zone III, the maximum unfavourable deviation may be respectively:

B 50 L (or R):	0.2 lx equivalent 20 per cent
	0.3 lx equivalent 30 per cent
Zone III	0.3 lx equivalent 20 per cent
	0.45 lx equivalent 30 per cent

1.2.2. or if

1.2.2.1. for the passing beam, the values prescribed in this Regulation are met at HV (with a tolerance of 0.2 lx) and related to that aiming at least one point of each area delimited on the measuring screen (at 25 m) by a circle 15 cm in radius around points B 50 L (or R) (with a tolerance of 0.1 lx), 75 R (or L), 50 V, 25 R, 25 L, and in the entire area of zone IV which is not more than 22.5 cm above line 25 R and 25 L;

1.2.2.2. and if, for the driving beam, HV being situated within the isolux $0.75 E_{\max}$, a tolerance of + 20 per cent for maximum values and - 20 per cent for minimum values is observed for the photometric values at any measuring point specified in paragraph 6.3.2. of this Regulation. The reference mark is disregarded.

1.2.3. If the results of the test described above do not meet the requirements, the alignment of the headlamp may be changed, provided that the axis of the beam is not displaced laterally by more than 1° to the right or left.^{1/}

1.2.4. If the results of the tests described above do not meet the requirements, tests shall be repeated using another standard filament lamp.

^{1/} See footnote 11/ in the text of this Regulation.

1.2.5. Headlamps with apparent defects are disregarded.

1.2.6. The reference mark is disregarded.

2. FIRST SAMPLING

In the first sampling four headlamps are selected at random. The first sample of two is marked A, the second sample of two is marked B.

2.1. The conformity is not contested

2.1.1. Following the sampling procedure shown in Figure 1 of this annex the conformity of mass-produced headlamps shall not be contested if the deviations of the measured values of the headlamps in the unfavourable directions are:

2.1.1.1. sample A

A1:	one headlamp		0 per cent
	one headlamp	not more than	20 per cent
A2:	both headlamps	more than	0 per cent
	but	not more than	20 per cent
	go to sample B		

2.1.1.2. sample B

B1:	both headlamps		0 per cent
-----	----------------	--	------------

2.1.2. or if the conditions of paragraph 1.2.2. for sample A are fulfilled.

2.2. The conformity is contested

2.2.1. Following the sampling procedure shown in Figure 1 of this annex the conformity of mass-produced headlamps shall be contested and the manufacturer requested to make his production meet the requirements (alignment) if the deviations of the measured values of the headlamps are:

2.2.1.1. sample A

A3:	one headlamp	not more than	20 per cent
	one headlamp	more than	20 per cent
	but	not more than	30 per cent

2.2.1.2. sample B

B2:	in the case of A2		
	one headlamp	more than	0 per cent
	but	not more than	20 per cent
	one headlamp	not more than	20 per cent
B3:	in the case of A2		
	one headlamp		0 per cent
	one headlamp	more than	20 per cent
	but	not more than	30 per cent

2.2.2. or if the conditions of paragraph 1.2.2. for sample A are not fulfilled.

2.3. Approval withdrawn

Conformity shall be contested and paragraph 11 applied if, following the sampling procedure shown in Figure 1 of this annex, the deviations of the measured values of the headlamps are:

2.3.1. sample A

A4:	one headlamp	not more than	20 per cent
	one headlamp	more than	30 per cent
A5:	Both headlamps	more than	20 per cent

2.3.2. sample B

B4:	in the case of A2		
	one headlamp	more than	0 per cent
	but	not more than	20 per cent
	one headlamp	more than	20 per cent
B5:	in the case of A2		
	both headlamps	more than	20 per cent
B6:	in the case of A2		
	one headlamp		0 per cent
	one headlamp	more than	30 per cent

2.3.3. or if the conditions of paragraph 1.2.2. for samples A and B are not fulfilled.

3. REPEATED SAMPLING

In the case of A3, B2, B3 a repeated sampling, third sample C of two headlamps, selected from stock manufactured after alignment, is necessary within two months' time after the notification.

3.1. The conformity is not contested

3.1.1. Following the sampling procedure shown in Figure 1 of this annex the conformity of mass-produced headlamps shall not be contested if the deviations of the measured values of the headlamps are:

3.1.1.1. sample C

C1:	one headlamp		0 per cent
	one headlamp	not more than	20 per cent
C2:	both headlamps	more than	0 per cent
	but	not more than	20 per cent
	go to sample D		

3.1.1.2. sample D

D1:	in the case of C2		
	both headlamps	0 per cent	

3.1.2. or if the conditions of paragraph 1.2.2. for sample C are fulfilled.

3.2. The conformity is contested

3.2.1. Following the sampling procedure shown in Figure 1 of this annex the conformity of mass-produced headlamps shall be contested and the manufacturer requested to make his production meet the requirements (alignment) if the deviations of the measured values of the headlamps are:

3.2.1.1. sample D

D2:	in the case of C2		
	one headlamp	more than	0 per cent
	but	not more than	20 per cent
	one headlamp	not more than	20 per cent

3.2.1.2. or if the conditions of paragraph 1.2.2. for sample C are not fulfilled.

3.3. Approval withdrawn

Conformity shall be contested and paragraph 11 applied if, following the sampling procedure shown in Figure 1 of this annex, the deviations of the measured values of the headlamps are:

3.3.1. sample C

C3:	one headlamp	not more than	20 per cent
	one headlamp	more than	20 per cent
C4:	both headlamps	more than	20 per cent

3.3.2. sample D

D3:	in the case of C2		
	one headlamp	0 or more than	0 per cent
	one headlamp	more than	20 per cent

3.3.3. or if the conditions of paragraph 1.2.2. for samples C and D are not fulfilled.

4. CHANGE OF THE VERTICAL POSITION OF THE CUT-OFF LINE

With respect to the verification of the change in vertical position of the cut-off line under the influence of heat, the following procedure shall be applied:

One of the headlamps of sample A after sampling procedure in Figure 1 of this annex shall be tested according to the procedure described in paragraph 2.1. of Annex 4 after being subjected three consecutive times to the cycle described in paragraph 2.2.2. of Annex 4.

The headlamp shall be considered as acceptable if Δr does not exceed 1.5 mrad.

If this value exceeds 1.5 mrad but is not more than 2.0 mrad, the second headlamp of sample A shall be subjected to the test after which the mean of the absolute values recorded on both samples shall not exceed 1.5 mrad.

However, if this value of 1.5 mrad on sample A is not complied with, the two headlamps of sample B shall be subjected to the same procedure and the value of Δr for each of them shall not exceed 1.5 mrad.

Figure 1

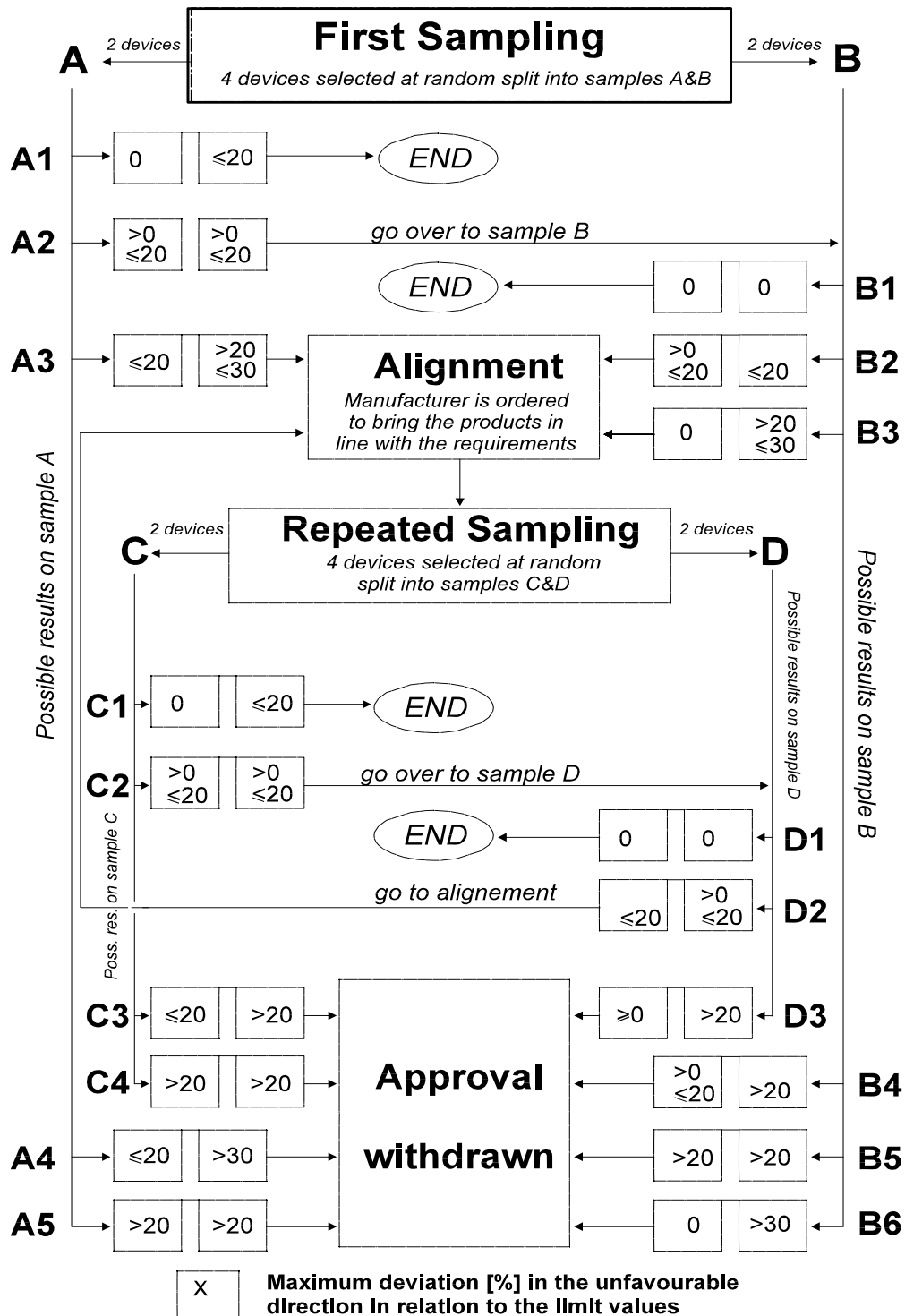

Maximum deviation [per cent] in the unfavourable

Annex 8

OVERVIEW OF OPERATIONAL PERIODS CONCERNING TESTS FOR STABILITY OF PHOTOMETRIC PERFORMANCE

- Abbreviations: P: passing beam lamp
 D: driving beam lamp (D₁ + D₂ means two driving beams)
 F: front fog lamp
 - - - - - : means a cycle of 15 minutes off and 5 minutes lit.

All following grouped headlamps and front fog lamps together with the added class B marking symbols are given as examples and are not exhaustive.

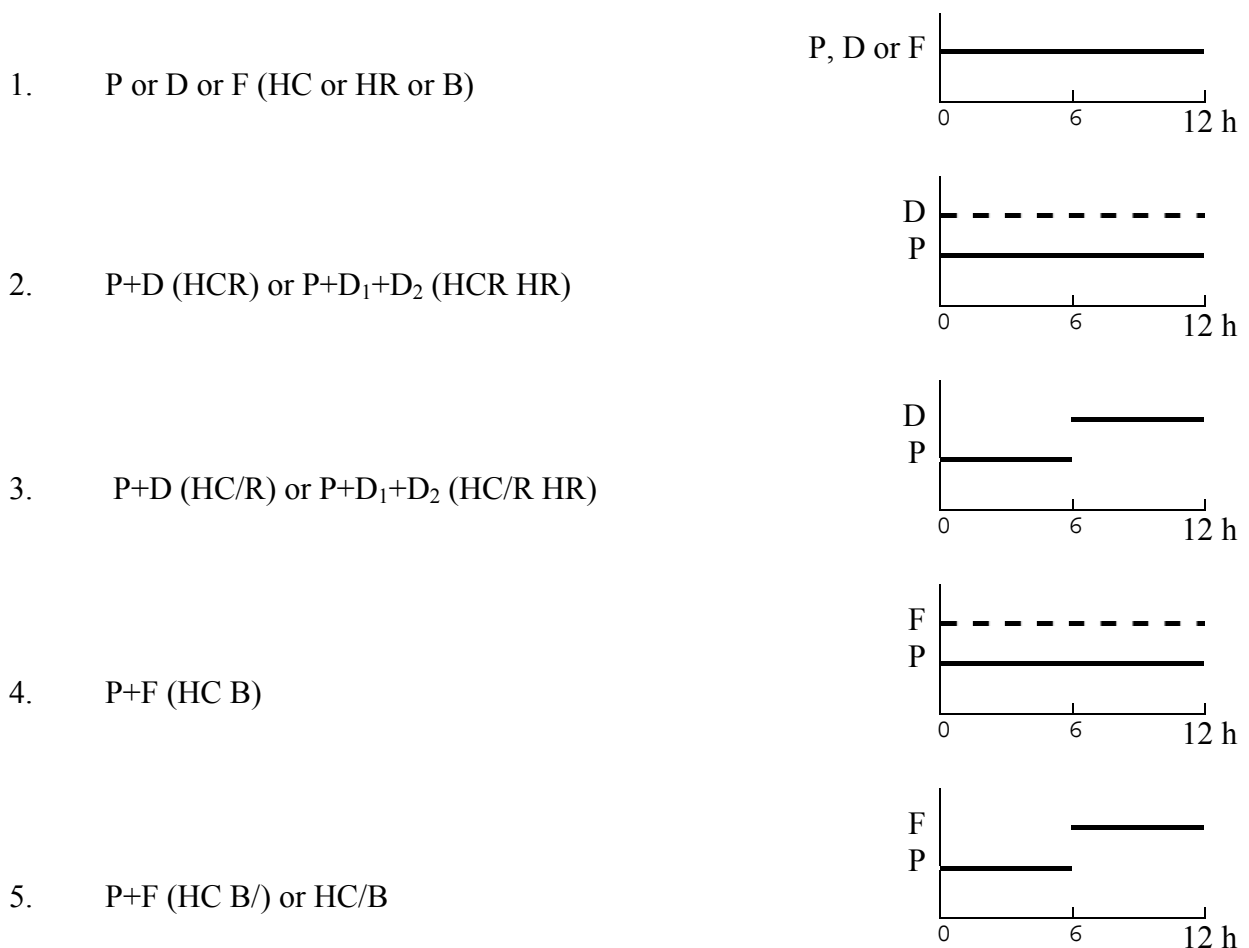

6. D+F (HR B) or D_1+D_2+F (HR HR B)

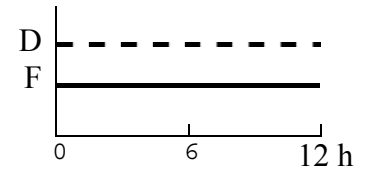

7. D+F (HR B/) or D_1+D_2+F (HR HR B/)

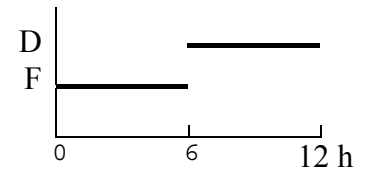

8. P+D+F (HCR B) or $P+D_1+D_2+F$ (HCR HR B)

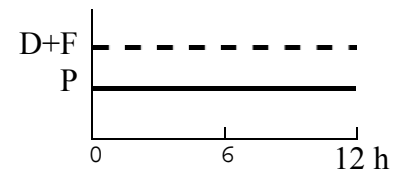

9. P+D+F (HC/R B) or $P+D_1+D_2+F$ (HC/R HR B)

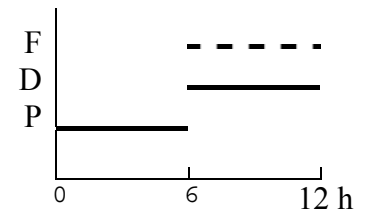

10. P+D+F (HCR B/) or $P+D_1+D_2+F$ (HCR HR B/)

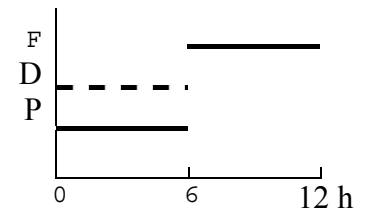

11. P+D+F (HC/R B/) or $P+D_1+D_2+F$ (HC/R HR B/)

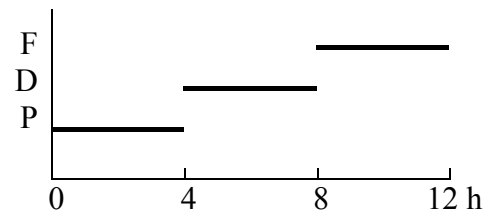

APPENDIX G
AGREEMENT

**CONCERNING THE ADOPTION OF UNIFORM TECHNICAL PRESCRIPTIONS FOR
WHEELED VEHICLES, EQUIPMENT AND PARTS WHICH CAN BE FITTED
AND/OR BE USED ON WHEELED VEHICLES AND THE CONDITIONS FOR
RECIPROCAL RECOGNITION OF APPROVALS GRANTED ON THE BASIS OF
THESE PRESCRIPTIONS ^{*/}**

(Revision 2, including the amendments which entered into force on 16 October 1995)

Addendum 112: Regulation No. 113

Revision 1

Incorporating all valid text up to:

Supplement 1 to the original version of the Regulation - Date of entry into force: 11 August 2002
Corrigendum 1 to original version of the Regulation, subject of Depository Notification C.N.38.2003.TREATIES-1 dated 17 January 2003
Supplement 2 to the original version of the Regulation - Date of entry into force: 27 February 2004
Corrigendum 1 to Supplement 2 to the original version of the Regulation, subject of Depository Notification C.N.448.2004.TREATIES-1 dated 13 May 2004
Corrigendum 2 to Supplement 2 to the original version of the Regulation, subject of Depository Notification C.N.1274.2005.TREATIES-1 dated 21 December 2005
Supplement 3 to the original version of the Regulation - Date of entry into force: 23 June 2005
Supplement 4 to the original version of the Regulation - Date of entry into force: 10 October 2006
Supplement 5 to the original version of the Regulation - Date of entry into force: 2 February 2007

**UNIFORM PROVISIONS CONCERNING THE APPROVAL OF MOTOR VEHICLE
HEADLAMPS EMITTING A SYMMETRICAL PASSING BEAM OR A DRIVING
BEAM OR BOTH AND EQUIPPED WITH FILAMENT LAMPS**



UNITED NATIONS

^{*/} Former title of the Agreement: Agreement Concerning the Adoption of Uniform Conditions of Approval and Reciprocal Recognition of Approval for Motor Vehicle Equipment and Parts, done at Geneva on 20 March 1958.

Regulation No. 113

UNIFORM PROVISIONS CONCERNING THE APPROVAL OF MOTOR VEHICLE
HEADLAMPS EMITTING A SYMMETRICAL PASSING BEAM OR A DRIVING BEAM
OR BOTH AND EQUIPPED WITH FILAMENT LAMPS

CONTENTS

REGULATION

A. ADMINISTRATIVE PROVISIONS

0. Scope
1. Definitions
2. Application for approval of a headlamp
3. Markings
4. Approval

B. TECHNICAL REQUIREMENTS FOR HEADLAMPS

5. General specifications
6. Illumination
7. Colour

C. FURTHER ADMINISTRATIVE PROVISIONS

8. Modification of the headlamp type and extension of approval
9. Conformity of production
10. Penalties for non-conformity of production
11. Production definitely discontinued
12. Names and addresses of Technical Services responsible for conducting approval tests, and of Administrative Departments

CONTENTS (continued)

ANNEXES

- Annex 1 - Communication concerning the approval or extension or refusal or withdrawal of approval or production definitely discontinued of a type of headlamp pursuant to Regulation No. 113
- Annex 2 - Examples of arrangement of approval marks
- Annex 3 - Measuring screen
- Annex 4 - Tests for stability of photometric performance on complete Class B, C and D headlamps
- Annex 5 - Minimum requirements for conformity of production control procedures
- Annex 6 - Requirements for lamps incorporating lenses of plastic material - testing of lens or material samples and of complete lamps
 - Appendix 1 - Chronological order of approval tests
 - Appendix 2 - Method of measurement of the diffusion and transmission of light
 - Appendix 3 - Spray testing method
 - Appendix 4 - Adhesive tape adherence test
- Annex 7 - Minimum requirements for sampling by an inspector
- Annex 8 - Overview of operational periods concerning test for stability of photometric performance
- Annex 9 - Definition and sharpness of the "cut-off" line for symmetrical passing-beam headlamps and aiming procedure by means of this cut-off line

A. ADMINISTRATIVE PROVISIONS

0. SCOPE ^{1/ 2/}

This Regulation applies to headlamps for vehicles of categories L and T ^{3/}.

1. DEFINITIONS

For the purpose of this Regulation,

1.1. "Lens" means the outermost component of the headlamp (unit) which transmits light through the illuminating surface;

1.2. "Coating" means any product or products applied in one or more layers to the outer face of a lens;

1.3. "Headlamps of different "types" mean headlamps which differ in such essential respects as:

1.3.1. the trade name or mark;

1.3.2. the characteristics of the optical system;

1.3.3. the inclusion or elimination of components capable of altering the optical effects by reflection, refraction, absorption and/or deformation during operation;

1.3.4. the kind of beam produced (passing beam, driving beam or both);

1.3.5. the materials constituting the lenses and coating, if any;

1.3.6. the category of filament lamp used;

1.4. "Headlamps of different "Classes" (A or B or C or D)" mean headlamps identified by particular photometric provisions.

2. APPLICATION FOR APPROVAL OF A HEADLAMP

2.1. The application for approval shall be submitted by the owner of the trade name or mark or by his duly accredited representative. It shall specify:

^{1/} Application of headlamps is given in the relevant Regulations on the installation of lighting and light-signalling devices.

^{2/} Nothing in this Regulation shall prevent a Party to the Agreement applying this Regulation from prohibiting the combination of a headlamp incorporating a lens of plastic material approved under this Regulation with a mechanical headlamp-cleaning device (with wipers).

^{3/} As defined in Annex 7 to the Consolidated Resolution on the Construction of Vehicles (R.E.3), (document TRANS/WP.29/78/Rev.1/Amend.2 as last amended by Amend 4).

- 2.1.1. whether the headlamp is intended to provide both a passing beam and a driving beam or only one of these beams;
 - 2.1.2. whether it concerns a Class A or B or C or D headlamp;
 - 2.1.3. the category of the filament lamp(s) used, as listed in Regulation No. 37.
 - 2.2. Every application for approval shall be accompanied by:
 - 2.2.1. drawings in triplicate in sufficient detail to permit identification of the type and representing a frontal view of the headlamp, with details of lens ribbing if any, and the cross-section; the drawings shall indicate the space reserved for the approval mark;
 - 2.2.2. a brief technical description;
 - 2.2.3. two samples of the type of headlamp;
 - 2.2.4. for Class B or C or D headlamps only, for the test of plastic material of which the lenses are made:
 - 2.2.4.1. thirteen lenses;
 - 2.2.4.1.1. six of these lenses may be replaced by six samples of material at least 60 x 80 mm in size, having a flat or convex outer surface and a substantially flat area (radius of curvature not less than 300 mm) in the middle measuring at least 15 x 15 mm;
 - 2.2.4.1.2. every such lens or sample of material shall be produced by the method to be used in mass production;
 - 2.2.4.2. a reflector to which the lenses can be fitted in accordance with the manufacturer's instructions.
 - 2.3. The materials making up the lenses and coatings, if any, shall be accompanied by the test report of the characteristics of these materials and coatings if they have already been tested.
3. MARKINGS
- 3.1. Headlamps submitted for approval shall bear the trade name or mark of the applicant.
 - 3.2. They shall comprise, on the lens and on the main body, ^{4/} spaces of sufficient size for the approval mark and the additional symbols referred to in paragraph 4; these spaces shall be indicated on the drawings referred to in paragraph 2.2.1. above.

^{4/} If the lens cannot be detached from the main body of the headlamp, a unique marking as per paragraph 4.2.5. shall be sufficient.

3.3. On the back of the headlamp the indication of the category of filament lamp used.

4. APPROVAL

4.1. General

4.1.1. If all the samples of a type of headlamp submitted pursuant to paragraph 2. above satisfy the provisions of this Regulation, approval shall be granted.

4.1.2. Where grouped, combined or reciprocally incorporated lamps satisfy the requirements of more than one Regulation, a single international approval mark may be affixed provided that each of the grouped, combined or reciprocally incorporated lamps satisfies the provisions applicable to it.

4.1.3. An approval number shall be assigned to each type approved. Its first two digits (at present 00) shall indicate the series of amendments incorporating the most recent major technical amendments made to the Regulation at the time of issue of the approval. The same Contracting Party may not assign the same number to another type of headlamp covered by this Regulation.

4.1.4. Notice of approval or of extension or refusal or withdrawal of approval or production definitely discontinued of a type of headlamp pursuant to this Regulation shall be communicated to the Parties to the 1958 Agreement applying this Regulation, by means of a form conforming to the model in Annex 1 to this Regulation.

4.1.5. In addition to the mark prescribed in paragraph 3.1., an approval mark as described in paragraphs 4.2. and 4.3. below shall be affixed in the spaces referred to in paragraph 3.2. above to every headlamp conforming to a type approved under this Regulation.

4.2. Composition of the approval mark

The approval mark shall consist of:

4.2.1. An international approval marking, comprising:

- 4.2.1.1. a circle surrounding the letter "E" followed by the distinguishing number of the country which has granted approval;^{5/}
- 4.2.1.2. the approval number prescribed in paragraph 4.1.3. above;
- 4.2.2. the following additional symbol:
 - 4.2.2.1. a horizontal arrow with a head on each end, pointing to the left and to the right;
 - 4.2.2.2. on headlamps meeting the requirements of this Regulation in respect of the passing beam only, the letters "C-AS" for Class A headlamps or "C-BS" for Class B headlamps or "WC-CS" for Class C headlamp or "WC-DS" for Class D headlamp;
 - 4.2.2.3. on headlamps meeting the requirements of this Regulation in respect of the driving beam only, "R-BS" for Class B headlamps or "WR-CS" for Class C headlamp or "WR-DS" for Class D headlamp;
 - 4.2.2.4. on headlamps meeting the requirements of this Regulation in respect of both the passing beam and the driving beam, the letters "CR-BS" for Class B headlamps or "WCR-CS" for Class C headlamp or "WCR-DS" for Class D headlamp;
 - 4.2.2.5. on headlamps incorporating a lens of plastic material, the group of letters "PL" to be affixed near the symbols prescribed in paragraphs 4.2.1. and 4.2.2. above.
 - 4.2.2.6. on headlamps, other than Class A, meeting the requirements of this Regulation in respect of the driving beam, an indication of the maximum luminous intensity expressed by a reference mark, as defined in paragraph 6.3.2.1.2. below, placed near the circle surrounding the letter "E";

^{5/} 1 for Germany, 2 for France, 3 for Italy, 4 for the Netherlands, 5 for Sweden, 6 for Belgium, 7 for Hungary, 8 for the Czech Republic, 9 for Spain, 10 for Serbia, 11 for the United Kingdom, 12 for Austria, 13 for Luxembourg, 14 for Switzerland, 15 (vacant), 16 for Norway, 17 for Finland, 18 for Denmark, 19 for Romania, 20 for Poland, 21 for Portugal, 22 for the Russian Federation, 23 for Greece, 24 for Ireland, 25 for Croatia, 26 for Slovenia, 27 for Slovakia, 28 for Belarus, 29 for Estonia, 30 (vacant), 31 for Bosnia and Herzegovina, 32 for Latvia, 33 (vacant), 34 for Bulgaria, 35 (vacant), 36 for Lithuania, 37 for Turkey, 38 (vacant), 39 for Azerbaijan, 40 for The former Yugoslav Republic of Macedonia, 41 (vacant), 42 for the European Community (Approvals are granted by its Member States using their respective ECE symbol), 43 for Japan, 44 (vacant), 45 for Australia, 46 for Ukraine, 47 for South Africa, 48 for New Zealand, 49 for Cyprus, 50 for Malta, 51 for the Republic of Korea, 52 for Malaysia, 53 for Thailand, 54 and 55 (vacant) and 56 for Montenegro. Subsequent numbers shall be assigned to other countries in the chronological order in which they ratify or accede to the Agreement Concerning the Adoption of Uniform Technical Prescriptions for Wheeled Vehicles, Equipment and Parts which can be Fitted and/or be Used on Wheeled Vehicles and the Conditions for Reciprocal Recognition of Approvals Granted on the Basis of these Prescriptions, and the numbers thus assigned shall be communicated by the Secretary-General of the United Nations to the Contracting Parties to the Agreement.

- 4.2.3. In every case the relevant operating mode used during the test procedure according to paragraph 1.1.1.1. of Annex 4 and the permitted voltage(s) according to paragraph 1.1.1.2. of Annex 4 shall be stipulated on the approval forms and on the communication forms transmitted to the countries which are Contracting Parties to the Agreement and which apply this Regulation.

In the corresponding cases the device shall be marked as follows:

- 4.2.3.1. on headlamps meeting the requirements of this Regulation which are so designed that the filament of the passing beam shall not be lit simultaneously with that of any other lighting function with which it may be reciprocally incorporated: an oblique stroke (/) shall be placed behind the passing lamp symbol in the approval mark.
- 4.2.4. The two digits of the approval number (at present 00) which indicate the series of amendments incorporating the most recent major technical amendments made to the Regulation at the time of issue of the approval and the arrow defined in paragraph 4.2.2.1. may be marked close to the above additional symbols.
- 4.2.5. The marks and symbols referred to in paragraphs 4.2.1. to 4.2.3. above shall be clearly legible and be indelible. They may be placed on an inner or outer part (transparent or not) of the headlamp, which cannot be separated from the transparent part of the headlamp emitting the light. In any case they shall be visible when the headlamp is fitted on the vehicle or when a movable part is opened.

4.3. Arrangement of the approval mark

- 4.3.1. Annex 2, figures 1 to 10, to this Regulation gives examples of arrangements of the approval mark with the above-mentioned additional symbols.
- 4.3.2. Grouped, combined or reciprocally incorporated lamps:
- 4.3.2.1. Where grouped, combined or reciprocally incorporated lamps have been found to comply with the requirements of several Regulations, a single international approval mark may be affixed, consisting of a circle surrounding the letter "E" followed by the distinguishing number of the country which has granted the approval, and an approval number. This approval mark may be located anywhere on the grouped, combined or reciprocally incorporated lamps, provided that:
- 4.3.2.1.1. it is visible as per paragraph 4.2.5.;
- 4.3.2.1.2. no part of the grouped, combined or reciprocally incorporated lamps that transmits light can be removed without at the same time removing the approval mark.
- 4.3.2.2. The identification symbol for each lamp appropriate to each Regulation under which approval has been granted, together with the corresponding series of amendments incorporating the most recent major technical amendments to the Regulation at the time of issue of the approval, and if necessary, the required arrow shall be marked:

- 4.3.2.2.1. either on the appropriate light-emitting surface,
- 4.3.2.2.2. or in a group, in such a way that each of the grouped, combined or reciprocally incorporated lamps may be clearly identified.
- 4.3.2.3. The size of the components of a single approval mark shall not be less than the minimum size required for the smallest of the individual marks by the Regulation under which approval has been granted.
- 4.3.2.4. An approval number shall be assigned to each type approved. The same Contracting Party may not assign the same number to another type of grouped, combined or reciprocally incorporated lamps covered by this Regulation.
- 4.3.2.5. Annex 2, figure 11, to this Regulation gives examples of arrangements of approval marks for grouped, combined or reciprocally incorporated lamps with all the above-mentioned additional symbols.

- 4.3.3. Lamps, the lens of which are used for different types of headlamps and which may be reciprocally incorporated or grouped with other lamps:

The provisions laid down in paragraph 4.3.2. above are applicable.

- 4.3.3.1. In addition, where the same lens is used, the latter may bear the different approval marks relating to the different types of headlamps or units of lamps, provided that the main body of the headlamp, even if it cannot be separated from the lens, also comprises the space described in paragraph 3.2. above and bears the approval marks of the actual functions. If different types of headlamps comprise the same main body, the latter may bear the different approval marks.
- 4.3.3.2. Annex 2, figure 12, to this Regulation gives examples of arrangements of approval marks relating to the above case.

B. TECHNICAL REQUIREMENTS FOR HEADLAMPS ^{6/}

5. GENERAL SPECIFICATIONS

- 5.1. Each sample shall conform to the specifications set forth in paragraphs 6. to 8. below.
- 5.2. Headlamps shall be so made as to retain their prescribed photometric characteristics and to remain in good working order when in normal use, in spite of the vibrations to which they may be subjected.
 - 5.2.1. Headlamps shall be fitted with a device enabling them to be so adjusted on the vehicles as to comply with the rules applicable to them. Such a device may or may

^{6/} Technical requirements for filament lamps: see Regulation No. 37.

not provide horizontal adjustment, provided that the headlamps are so designed that they can maintain a proper horizontal aiming even after the vertical aiming adjustment. Such a device need not be fitted on units in which the reflector and the diffusing lens cannot be separated, provided the use of such units is confined to vehicles on which the headlamp setting can be adjusted by other means.

Where a headlamp providing a passing beam and a headlamp providing a driving beam, each equipped with its own filament lamp, are assembled to form a composite unit the adjusting device shall enable each optical system individually to be duly adjusted.

- 5.2.2. However, these provisions shall not apply to headlamp assemblies whose reflectors are indivisible. For this type of assembly the requirements of paragraph 6.3. of this Regulation apply.
- 5.3. The headlamp shall be equipped with filament lamp(s) approved according to Regulation No. 37. Any Regulation No. 37 filament lamp may be used, provided that:
- (a) no restriction on the application is made in the table of contents of that Regulation;
 - (b) for Class A and B, its reference luminous flux for dipped-beam does not exceed 600 lm;
 - (c) for Class C and D, its objective luminous flux for dipped-beam does not exceed 2000 lm.
- 5.4. The components by which a filament lamp is fixed to the reflector shall be so made that, even in darkness, the filament lamp can be fixed in no position but the correct one.^{7/}
- 5.5. The filament lamp holder shall conform to the characteristics given in IEC Publication 61-2, third edition, 1969. The holder data sheet relevant to the category of filament lamp used, applies.
- 5.6. In addition, Class B or C or D headlamps shall be complementary tested according to the requirements of Annex 4 to ensure that in use there is no excessive change in photometric performance.
- 5.7. If the lens of a Class B or C or D headlamp is of plastic material, tests shall be done according to the requirements of Annex 6.

^{7/} A headlamp is regarded as satisfying the requirements of this paragraph if the filament lamp can be easily fitted into the headlamp and the positioning lugs can be correctly fitted into their slots even in darkness.

- 5.8. On headlamps designed to provide alternately a driving beam and a passing beam, any mechanical, electromechanical or other device incorporated in the headlamp for switching from one beam to the other shall be so constructed that:
- 5.8.1. the device is strong enough to withstand 50,000 operations without suffering damage despite the vibrations to which it may be subjected in normal use;
- 5.8.2. in the case of failure it shall automatically obtain the passing beam position;
- 5.8.3. either the passing beam or the driving beam shall always be obtained without any possibility of the mechanism stopping in between the two positions;
- 5.8.4. the user cannot, with ordinary tools, change the shape or position of the moving parts.

6. ILLUMINATION

6.1. General provisions

- 6.1.1. Headlamps shall be so made that they give adequate illumination without dazzle when emitting the passing beam, and good illumination when emitting a driving beam.
- 6.1.2. The illumination produced by the headlamp shall be determined by means of a vertical screen set up 25 m forward of the headlamp and at right angles to its axes as shown in Annex 3 to this Regulation.
- 6.1.3. Headlamps shall be checked by means of an uncoloured standard (étalon) filament lamp designed for a rated voltage as indicated in the relevant data sheet of Regulation No. 37. During the checking of the headlamp, the voltage at the terminals of the filament lamp shall be regulated so as to obtain the reference luminous flux as indicated at the relevant data sheet of Regulation No. 37.
- 6.1.4. The headlamp shall be considered acceptable if it meets the requirements of this paragraph 6 with at least one standard (étalon) filament lamp, which may be submitted with the headlamp.

6.2. Provisions concerning passing beams

- 6.2.1. For a correct aiming the passing beam shall produce a sufficiently sharp "cut-off" to permit a satisfactory visual adjustment with its aid as indicated in paragraph 6. below. The "cut-off" must be substantially horizontal and shall be as straight as possible from at least 3° L to 3° R for Class A, B, C and D headlamps. In case that visual aim leads to problems or ambiguous positions, the instrumental method as specified in Annex 9, paragraphs 2. and 4., shall be applied and the quality or rather the sharpness of the "cut-off" and the linearity shall be checked on performance.

- 6.2.2. The headlamp shall be so aimed that:
- 6.2.2.1. For horizontal adjustment: The beam is as symmetrical as possible with reference to line V-V;
- 6.2.2.2. For vertical adjustment: The horizontal part of the "cut-off" line is adjusted to its nominal position 1 per cent below the H-H-line which is 10 cm below the headlamp axis on the screen at 10 m distance or which is 25 cm below the headlamp axis on the screen at 25 m distance.

If, however, vertical adjustment cannot be performed repeatedly to the required position within the allowed tolerances, the instrumental method of Annex 9, paragraphs 4. and 5. shall be applied to test compliance with the required minimum quality of the "cut-off" line and to perform the beam vertical adjustment.

- 6.2.3. When so aimed, the headlamp need, if its approval is sought solely for provision of a passing beam, ^{8/} comply only with the requirements set out in paragraphs 6.2.5. to 6.2.6. below; if it is intended to provide both a passing beam and a driving beam, it shall comply with the requirements set out in paragraphs 6.2.5., 6.2.6. and 6.3.
- 6.2.4. Where a headlamp so aimed does not meet the requirements set out in paragraphs 6.2.5., 6.2.6. and 6.3., its alignment may be changed, except for headlamps that have no mechanism to adjust horizontal aim, on condition that the axis of the beam is not displaced laterally by more than 1 degree (= 44 cm) to the right or left ^{2/}. To facilitate alignment by means of the "cut-off", the headlamp may be partially occulted in order to sharpen the "cut-off". However, the "cut-off" should not extend beyond the line H-H.
- 6.2.5. The illumination produced by the passing beam on the screens in Annex 3 shall meet the following illumination requirements:

- 6.2.5.1. For Class A headlamps:

Any point on and above the line H-H	≤ 0.32 lux
Any point on line 25L-25R	≥ 1.28 lux
Any point on line 12.5L-12.5R	≥ 0.64 lux

^{8/} Such a special "passing beam" headlamp may incorporate a driving beam not subject to requirements.

^{2/} The limit of realignment of 1° towards the right or left is not incompatible with upward or downward vertical realignment. The latter is limited only by the requirements of paragraph 6.3. (the provisions of paragraph 6.3. are not applicable to passing beam headlamps).

6.2.5.2. For Class B headlamps:

Any point on and above the line H-H	≤ 0.7 lux
Any point on line 50L-50R except 50V */	≥ 1.5 lux
Point 50V	≥ 3 lux
Any point on line 25L-25R	≥ 3 lux
Any point in zone IV	≥ 1.5 lux

*/ ratio of intensities $\frac{50R}{50L} \geq 0.25$

6.2.5.3. For Class C or D headlamp:

TEST POINT/ LINE/ ZONE	Position in B-β Grid in angular degrees Vertical β** Horizontal B**		Required illumination in lux at 25 m			
			Minimum		Maximum	
			Class D	Class C	Class D	Class C
			> 125cc	≤ 125cc	> 125cc	≤ 125cc
1	0.86 D	3.5 R	2.3		15.4	
2	0.86 D	0	5.8	2.9	-	
3	0.86 D	3.5 L	2.3		15.4	
4	0.50 U	1.50 L & 1.50 R	-		1.08	
6	2.00 D	15 L & 15 R	1.28	0.64	-	
7	4.00 D	20 L & 20 R	0.38	0.19	-	
8	0	0	-		1.92	
Line 11	2.00 D	9 L to 9 R	1.6		-	
Line 12	7.00 U	10 L to 10 R	-		0.3; but 0.96 if within 2° cone	
Line 13	10.00 U	10 L to 10 R	-		0.15; but 0.64 if within 2° cone	
Line 14	10 U to 90 U	0	-		0.15; but 0.64 if within 2° cone	
15*	4.00 U	8.0 L	0.1*		1.08	
16*	4.00 U	0	0.1*		1.08	
17*	4.00 U	8.0 R	0.1*		1.08	
18*	2.00 U	4.0 L	0.2*		1.08	
19*	2.00 U	0	0.2*		1.08	
20*	2.00 U	4.0 R	0.2*		1.08	
21*	0	8.0 L & 8.0 R	0.1*		-	
22*	0	4.0 L & 4.0 R	0.2*		1.08	
Zone 1	1U/8L-4U/8L-4U/8R-1U/8R-0/4R-0/1R-0.6U/0-0/1L-0/4L-1U/8L		-		1.08	
Zone 2	>4U to <10 U	10 L to 10 R	-		0.3; but 0.96 if within 2° cone	
Zone 3	10 U to 90 U	10 L to 10 R	-		0.15; but 0.64 if within 2° cone	

Notes:

"D" means under the H-H line.

"U" means above the H-H line.

"R" means right of the V-V line.

"L" means left of the V-V line.

* During measurement of these points, the front position lamp approved to Regulation No. 50; if combined, grouped, or reciprocally incorporated shall be switched on.

** 0.25° tolerance allowed independently at each test point for photometry unless indicated otherwise.

Other general text:

ECE type approval at reference luminous flux according to Regulation No. 37 or at objective luminous flux for gas-discharge light sources according to Regulation No. 99.

Nominal aim for photometry:

Vertical: 1 per cent D (0.57°D) Horizontal: 0°

Allowed tolerances for photometry:

Vertical: 0.3°D to 0.8°D Horizontal: ± 0.5°D L-R

6.2.6. The light shall be as evenly distributed as possible within zones 1, 2, and 3 for Class C or D headlamps.

6.3. Provisions concerning driving beams

6.3.1. In the case of a headlamp designed to provide a driving beam and a passing beam, measurements of the illumination produced on the screen by the driving beam shall be taken with the same headlamp alignment as applied to the condition of paragraphs 6.2. above; in the case of a headlamp providing a driving beam only, it shall be so adjusted that the area of maximum illumination is centred on the point of intersection of lines H-H and V-V; such a headlamp need meet only the requirements referred to in paragraph 6.3.

6.3.2. Except for Class A headlamp, the illumination produced on the screen by the driving beam shall meet the following requirements:

6.3.2.1. The point of intersection (HV) of lines H-H and V-V shall be situated within the isolux 80 per cent of maximum illumination. This maximum value (E_M) shall not be less than 32 lux for Class B or C headlamps and 51.2 lux for Class D headlamps. The maximum value shall in no circumstances exceed 240 lux in the case of Class B headlamps and 180 lux in the case of Class C and D headlamps.

6.3.2.1.1. The maximum intensity (I_M) of the driving beam expressed in thousands of candelas shall be calculated by the formula:

$$I_M = 0.625 E_M$$

- 6.3.2.1.2. The reference mark (I'_M) of this maximum intensity, referred to in paragraph 4.2.2.6. above, shall be obtained by the ratio:

$$I'_M = \frac{I_M}{3} = 0.208 E_M$$

This value shall be rounded off to the value 7.5 - 10 - 12.5 - 17.5 - 20 - 25 - 27.5 - 30 - 37.5 - 40 - 45 - 50.

- 6.3.2.2. Starting from point HV, horizontally to the right and left, the illumination shall be not less than 12 lux for Class B headlamp to a distance of 1,125 mm and not less than 3 lux for Class B headlamp to a distance of 2,250 mm.

In the case of a Class C or D headlamp, the intensities shall conform to the tables A or B in Annex 3. Table A applies in the case where a primary driving beam is being produced with a single light source. Table B applies in the case where the driving beam is being produced by a secondary driving beam headlamp operated with a harmonized passing beam headlamp or a primary driving beam headlamp.

- 6.4. In the case of headlamps with an adjustable reflector, additional tests shall be made after the reflector has been moved vertically ± 2 degrees or at least into the maximum position, if less than 2 degrees, from its initial position by means of the headlamp adjusting device. The whole headlamp shall then be re-positioned (for example by means of the goniometer) by moving it through the same number of degrees in the opposite direction to the movement of the reflector. The following measurements shall be made and the points shall be within the required limits:
passing beam: points HV and 0.86D-V
driving beam: I_M and point HV (percentage of I_M)

- 6.5. The screen illumination values mentioned in paragraphs 6.2. and 6.3. above shall be measured by means of a photoreceptor, the effective area of which shall be contained within a square of 65 mm side.

7. COLOUR

- 7.1. The colour of the light emitted shall be white. Expressed in CIE trichromatic coordinates, the light of the beams shall be within the following boundaries:

limit towards blue	$x \geq 0.310$
limit towards yellow	$x \leq 0.500$
limit towards green	$y \leq 0.150 + 0.640 x$
limit towards green	$y \leq 0.440$
limit towards purple	$y \geq 0.050 + 0.750 x$
limit towards red	$y \geq 0.382$

C. FURTHER ADMINISTRATIVE PROVISIONS

8. MODIFICATION OF THE HEADLAMP TYPE AND EXTENSION OF APPROVAL

- 8.1. Every modification of the headlamp type shall be notified to the administrative department which approved the headlamp type. The said department may then either:
- 8.1.1. consider that the modifications made are unlikely to have appreciable adverse effects and that in any event the headlamp still complies with the requirements; or
 - 8.1.2. require a further test report from the Technical Service responsible for conducting the tests.
- 8.2. Confirmation or refusal of approval, specifying the alterations, shall be communicated by the procedure specified in paragraph 4.1.4. above to the Parties to the Agreement which apply this Regulation.
- 8.3. The Competent Authority issuing the extension of approval shall assign a series number to each communication form drawn up for such an extension and inform thereof the other Parties to the 1958 Agreement applying this Regulation by means of a communication form conforming to the model in Annex 1 to this Regulation.

9. CONFORMITY OF PRODUCTION

The conformity of production procedures shall comply with those set out in the Agreement, Appendix 2 (E/ECE/324-E/ECE/TRANS/505/Rev.2) with the following requirements:

- 9.1. Headlamps approved under this Regulation shall be so manufactured as to conform to the type approved by meeting the requirements set forth in paragraphs 6. and 7.
- 9.2. The minimum requirements for conformity of production control procedures set forth in Annex 5 to this Regulation shall be complied with.
- 9.3. The minimum requirements for sampling by an inspector set forth in Annex 7 to this Regulation shall be complied with.
- 9.4. The authority which has granted type approval may at any time verify the conformity control methods applied in each production facility. The normal frequency of these verifications shall be once every two years.
- 9.5. Headlamps with apparent defects are disregarded.

10. PENALTIES FOR NON-CONFORMITY OF PRODUCTION

10.1. The approval granted in respect of a type of headlamp pursuant to this Regulation may be withdrawn if the requirements are not complied with or if a headlamp bearing the approval mark does not conform to the type approved.

10.2. If a Contracting Party to the Agreement applying this Regulation withdraws an approval it has previously granted, it shall forthwith so notify the other Contracting Parties applying this Regulation by means of a communication form conforming to the model in Annex 1 to this Regulation.

11. PRODUCTION DEFINITELY DISCONTINUED

If the holder of the approval completely ceases to manufacture a type of headlamp approved in accordance with this Regulation, he shall so inform the authority which granted the approval. Upon receiving the relevant communication, that authority shall inform thereof the other Parties to the 1958 Agreement applying this Regulation by means of a communication form conforming to the model in Annex 1 to this Regulation.

12. NAMES AND ADDRESSES OF TECHNICAL SERVICES RESPONSIBLE FOR CONDUCTING APPROVAL TESTS, AND OF ADMINISTRATIVE DEPARTMENTS

The Parties to the 1958 Agreement applying this Regulation shall communicate to the United Nations Secretariat the names and addresses of the Technical Services responsible for conducting approval tests and of the administrative departments which grant approval and to which forms certifying approval or extension or refusal or withdrawal of approval, or production definitely discontinued, issued in other countries, are to be sent.

Annex 1

COMMUNICATION

(Maximum format: A4 (210 x 297 mm))

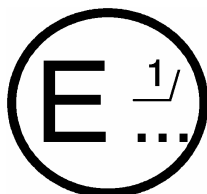

issued by :

Name of administration:

.....
.....
.....

concerning: ^{2/}

- APPROVAL GRANTED
- APPROVAL EXTENDED
- APPROVAL REFUSED
- APPROVAL WITHDRAWN
- PRODUCTION DEFINITELY DISCONTINUED

of a type of headlamp pursuant to Regulation No. 113

Approval No.:

Extension No.:

1. Trade name or mark of the device:
2. Manufacturer's name for the type of device:.....
3. Manufacturer's name and address:
4. If applicable, name and address of manufacturer's representative:.....
.....
5. Submitted for approval on:
6. Technical Service responsible for conducting approval tests:.....
.....
7. Date of report issued by that service:.....
8. Number of report issued by that service:
9. Brief description:

Category as described by the relevant marking ^{3/} :

- Number and category(ies) of filament lamp(s):
1.
2.
- The determination of cut-off sharpness yes / no ^{2/}
3. I
- f yes, it was carried out at 10 m / 25 m ^{2/}
10. Approval mark position:
11. Reason(s) for extension of approval:
12. Approval granted/extended/refused/withdrawn ^{2/}:
13. Place:
14. Date:
15. Signature:
16. The list of documents deposited with the Administrative Service which has granted approval is annexed to this communication and may be obtained on request.

^{1/} Distinguishing number of the country which has granted/extended/refused/withdrawn approval (see the provisions of the Regulation concerning approval).

^{2/} Strike out which does not apply.

^{3/} Indicate the appropriate marking selected from the listed below:

C-AS,	C-BS,	R-BS,	CR-BS,	C/ -BS,	C/R-BS,
	C-BS PL,	R-BS PL,	CR-BS PL,	C/ -BS PL,	C/R-BS PL,
WC-CS,	WC-DS,	WR-CS,	WR-DS,	WCR-CS,	WCR-DS,
WC/-CS,	WC/-DS,	WC/R-CS,	WC/R-DS,	WC-CS PL,	
WC-DS PL,	WR-CS PL,	WR-DS PL,	WCR-CS PL,	WCR-DS PL,	
WC/-CS PL,	WC/-DS PL,	WC/R-CS PL,	WC/R-DS PL,		
WC+-CS,	WC+-DS,	WC+R-CS,	WC+R-DS,	C+-BS,	C+R-BS,
WC+-CS PL,	WC+-DS PL,	WC+R-CS PL,	WC+R-DS PL,	C+-BS PL,	C+R-BS PL

Annex 2

EXAMPLES OF ARRANGEMENT OF APPROVAL MARKS

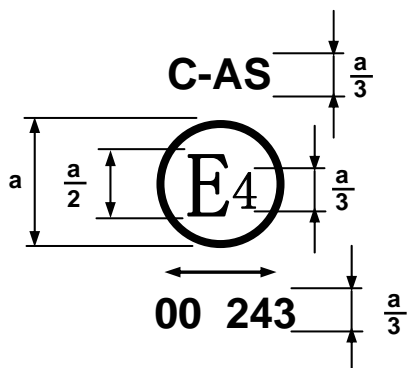

Figure 1



Figure 2

$a \geq 5$ mm for Class A headlamp

$a \geq 8$ mm for Class B, C and D headlamp

The headlamp bearing one of the above approval marks has been approved in the Netherlands (E4) pursuant to Regulation No. 113 under approval number 243, meeting the requirements of this Regulation in its original form (00). The letters C-AS (Figure 1) indicate that it concerns a Class A passing beam headlamp and the letters CR-BS (Figure 2) indicate that it concerns a Class B passing and driving beam headlamp.

Notes: The approval number and additional symbols shall be placed close to the circle and either above or below the letter "E", or to the right or left of that letter. The digits of the approval number shall be on the same side of the letter "E" and face in the same direction.

The use of Roman numerals as approval numbers should be avoided so as to prevent any confusion with the other symbols.

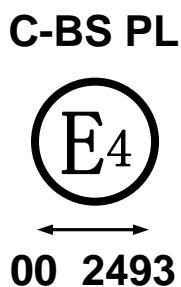

Figure 3

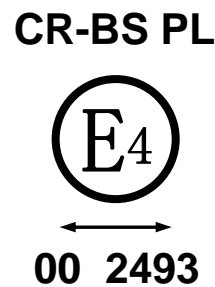

Figure 4

The headlamp bearing the above approval mark is a headlamp incorporating a lens of plastic material meeting the requirements of this Regulation and is designed:

Figure 3: Class B in respect of the passing beam only.

Figure 4: Class B in respect of the passing beam and driving beam.

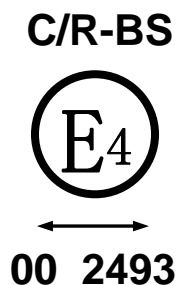

Figure 5

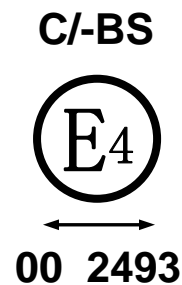

Figure 6

The headlamp bearing the above approval mark is a headlamp meeting the requirements of this Regulation:

Figure 5: Class B in respect of the passing beam and driving beam.

Figure 6: Class B in respect of the passing beam only.

The passing beam shall not operated simultaneously with the driving beam and/or another reciprocally incorporated headlamp.

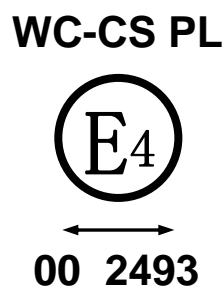

Figure 7

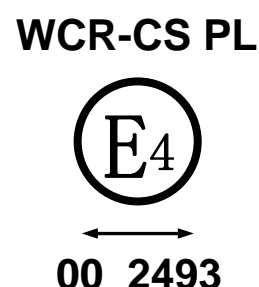

Figure 8

The headlamp bearing the above approval mark is a headlamp incorporating a lens of plastic material meeting the requirements of this Regulation and is designed:

Figure 7: Class C in respect of the passing beam only.

Figure 8: Class C in respect of the passing beam and driving beam.

WC-DS PL

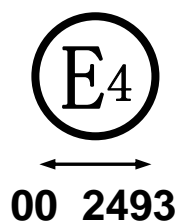

Figure 9

WCR-DS PL

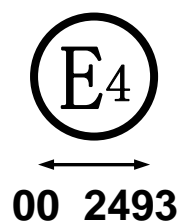

Figure 10

The headlamp bearing the above approval mark is a headlamp meeting the requirements of this Regulation:

Figure 9: Class D in respect of the passing beam and driving beam.

Figure 10: Class D in respect of the passing beam only.

The passing beam shall not be operated simultaneously with the driving beam and/or another reciprocally incorporated headlamp.

Simplified marking for grouped, combined or reciprocally incorporated lamps

Figure 11

(The vertical and horizontal lines schematize the shape of the light-signalling device. They are not part of the approval mark).

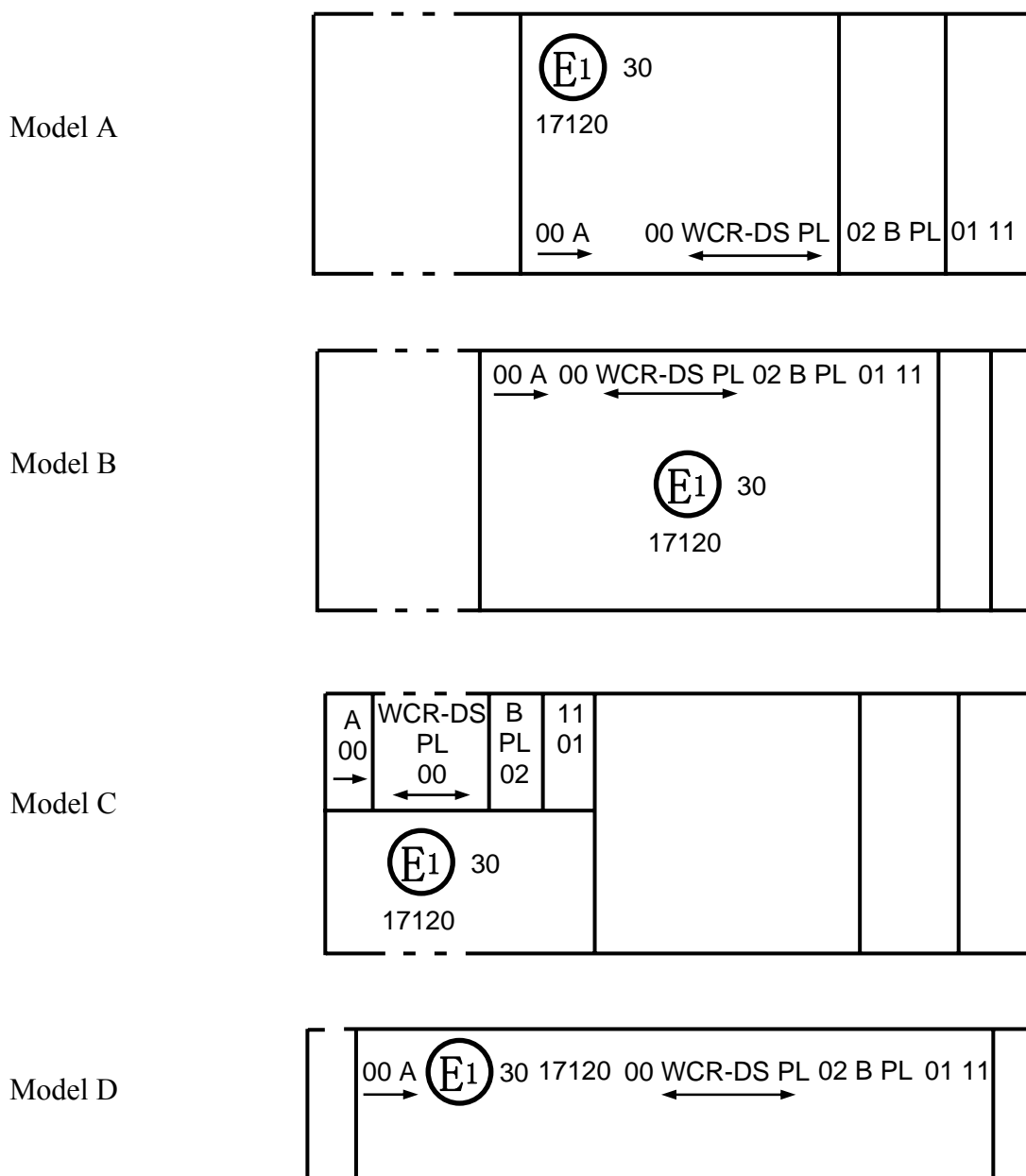

Note: The four examples above correspond to a lighting device bearing an approval mark comprising:

A front position lamp approved in accordance with Regulation No. 50 in its original form (00),

A headlamp, Class D, with a passing beam and a driving beam with a maximum intensity comprised between 86 250 and 101 250 candelas (as indicated by the number 30), approved in accordance with the requirements of this Regulation in its original form (00) and incorporating a lens of plastic material,

A front fog lamp approved in accordance with the 02 series of amendments to Regulation No. 19 and incorporating a lens of plastic material,

A front direction indicator lamp of category 11 approved in accordance with the 01 series of amendments to Regulation No. 50.

Figure 12

Lamp reciprocally incorporated with a headlamp

Example 1

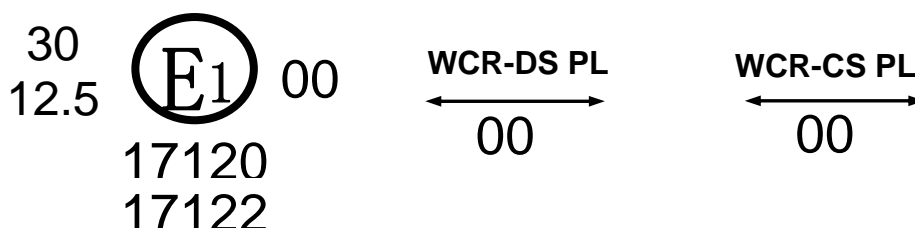

The above example corresponds to the marking of a lens of plastic material intended to be used in different types of headlamps, namely:

Either A headlamp, Class D, with a passing and a driving beam with a maximum luminous intensity comprised between 86 250 and 101 250 candelas (as indicated by the number 30), approved in Germany (E1) in accordance with the requirements of this Regulation in its original form (00), which is reciprocally incorporated with a front position lamp approved in accordance with Regulation No. 50 in its original form (00);

Or A headlamp, Class C, with a passing beam and a driving beam with a maximum luminous intensity comprised between 33 750 cd and 45 000 cd (as indicated by the number 12.5), approved in Germany (E1) in accordance with the requirements of this Regulation in its original form (00), which is reciprocally incorporated with the same front position lamp as above.

Annex 3

MEASURING SCREEN for Class A headlamps
 (Dimensions in mm with screen at 25 m distance)

Figure A

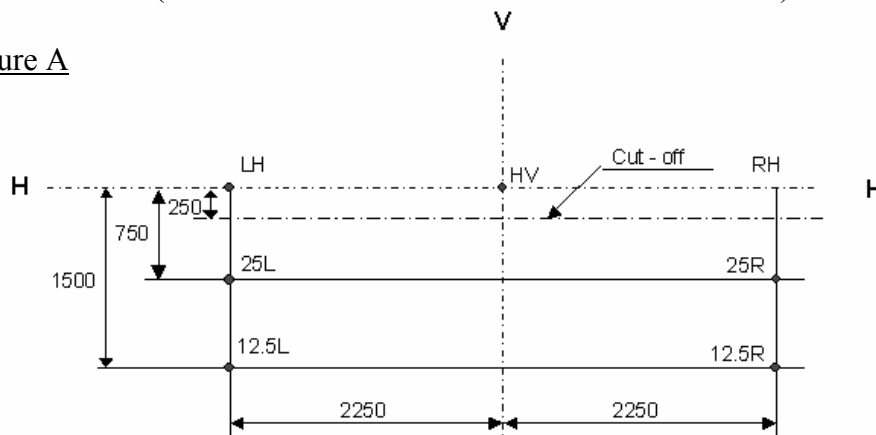

H-H : horizontal plane)
 V-V : vertical plane)
 passing through
 focus of headlamp

MEASURING SCREEN for Class B headlamps
 (Dimensions in mm with screen at 25 m distance)

Figure B

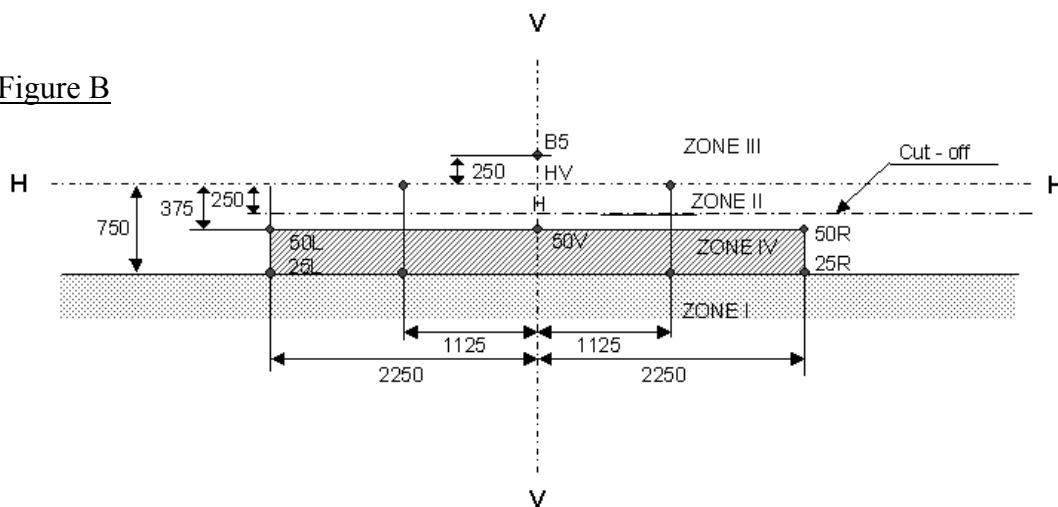

H-H : horizontal plane)
 V-V : vertical plane)
 passing through
 focus of headlamp

MEASURING SCREEN for Class C and D headlamps
(Dimensions in mm with screen at 25 m distance)

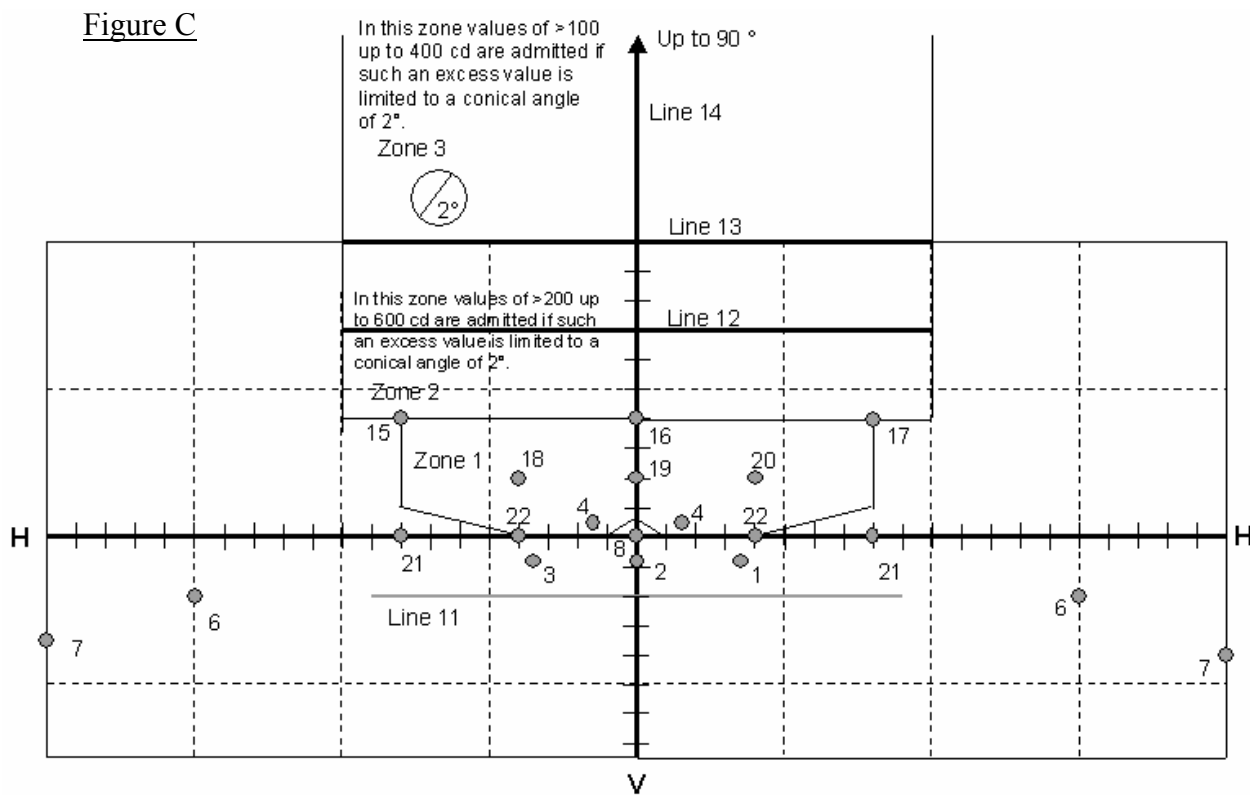

Table A - Primary high beam headlamp

Refer to Figure D for details of test point positions

TEST POINT NUMBER	TEST POINT LOCATION	Required illumination in lux			
		Class D		Class C	
		> 125cc		≤ 125cc	
		MIN.	MAX.	MIN.	MAX.
1	H-V (1)	(1)	---	(1)	---
2	H-3R & 3L	19.2	---	12.8	---
3	H-6R & 6L	6.4	---	4.16	---
4	H-9R & 9L	3.84	---	2.56	---
5	H-12R & 12L	1.28	---	0.8	---
6	2U-V	1.92	---	1.28	---
7	4D-V	---	(2)	---	(2)
	MIN. LUMINOUS INTENSITY OF THE MAXIMUM	51.2	---	32	---
	MAX. LUMINOUS INTENSITY	---	180.0	---	180.0

- (1) Intensity at H-V shall be equal to or greater than 80 per cent of the maximum intensity in the beam pattern.
- (2) Intensity at 4d-v shall be equal to or less than 30 per cent of the maximum intensity in the beam pattern.

Table B - Secondary high beam headlamp operated with a harmonized passing beam headlamp or a primary driving beam headlamp

Refer to Figure E for details of test point positions

TEST POINT NUMBER	TEST POINT LOCATION	Required illumination in lux			
		Class D		Class C	
		> 125cc		≤ 125cc	
		MIN.	MAX.	MIN.	MAX.
1	H-V (1)	(1)	---	(1)	---
2	H-3R & 3L	19.2	---	12.8	---
3	H-6R & 6L	6.4	---	4.16	---
6	2U-V	1.92	---	1.28	---
7	4D-V	---	(2)	---	(2)
	MIN. LUMINOUS INTENSITY OF THE MAXIMUM	51.2	---	32	---
	MAX. LUMINOUS INTENSITY	---	180.0	---	180.0

- (1) Intensity at H-V shall be equal to or greater than 80 per cent of the maximum intensity in the beam pattern.
- (2) Intensity at 4D-V shall be equal to or less than 30 per cent of the maximum intensity in the beam pattern.

Figure D
Primary Driving Beam

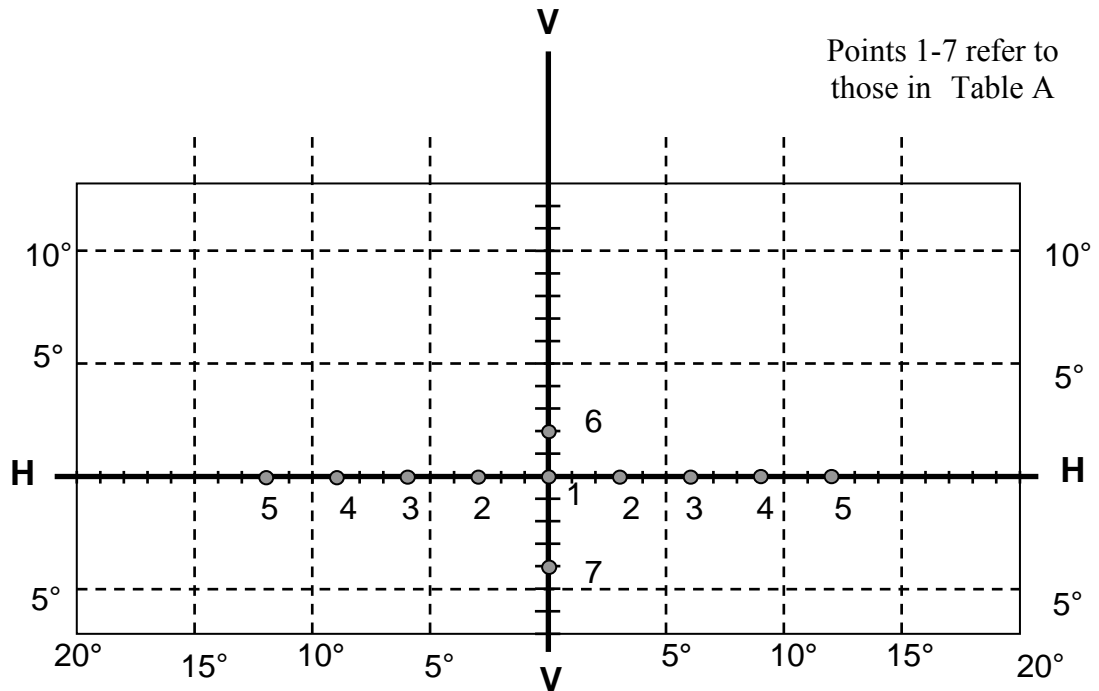
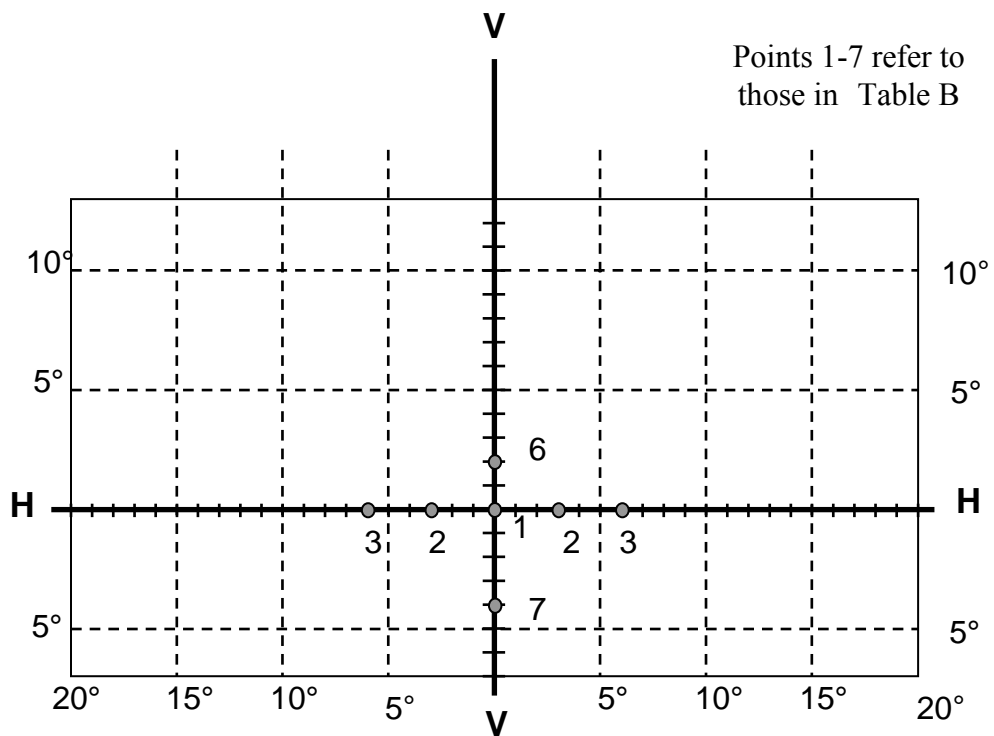

Figure E
Secondary Driving



Annex 4

TESTS FOR STABILITY OF PHOTOMETRIC PERFORMANCE ON COMPLETE CLASS B, C AND D HEADLAMPS

TESTS ON COMPLETE CLASS B HEADLAMPS

Once the photometric values have been measured according to the prescriptions of this Regulation, in the point for E_{\max} for driving beam and in points HV, 50R, 50L and B50 for passing beam a complete headlamp sample shall be tested for stability of photometric performance in operation. "Complete headlamp" shall be understood to mean the complete lamp itself including those surrounding body parts and lamps which could influence its thermal dissipation.

1. TEST FOR STABILITY OF PHOTOMETRIC PERFORMANCE

The tests shall be carried out in a dry and still atmosphere at an ambient temperature of $23\text{ }^{\circ}\text{C} \pm 5\text{ }^{\circ}\text{C}$, the complete headlamp being mounted on a base representing the correct installation on the vehicle.

1.1. Clean headlamp

The headlamp shall be operated for 12 hours as described in paragraph 1.1.1. and checked as prescribed in paragraph 1.1.2.

1.1.1. Test procedure^{1/}

The headlamp shall be operated for a period according to the specified time, so that:

- 1.1.1.1. (a) In the case where only one lighting function (driving or passing beam or front fog lamp) is to be approved, the corresponding filament is lit for the prescribed time,^{2/}
- (b) In the case of a headlamp with a passing beam and one or more driving beams or in case of a headlamp with a passing beam and a front fog lamp:
 - (i) the headlamp shall be subjected to the following cycle until the time specified is reached:
15 minutes, passing-beam filament lit;
5 minutes, all filaments lit.

^{1/} For the test schedule see Annex 8 to this Regulation.

^{2/} When the tested headlamp includes signalling lamps, the latter shall be lit for the duration of the test. In the case of a direction indicator lamp, it shall be lit in flashing mode with an on/off time of approximately one to one.

- (ii) if the applicant declares that the headlamp is to be used with only the passing beam lit or only the driving beam(s) lit ^{3/} at a time, the test shall be carried out in accordance with this condition, activating ^{2/} successively the passing beam half of the time and the driving beam(s) (simultaneously) for half the time specified in paragraph 1.1. above.
- (c) in the case of a headlamp with a front fog lamp and one or more driving beams:
- (i) the headlamp shall be subjected to the following cycle until the time specified is reached:
15 minutes, front fog lamp lit;
5 minutes, all filaments lit.
- (ii) if the applicant declares that the headlamp is to be used with only the front fog lamp lit or only the driving beam(s) lit ^{3/} at a time, the test shall be carried out in accordance with this condition, activating ^{2/} successively the front fog lamp half of the time and the driving beam(s) (simultaneously) for half the time specified in paragraph 1.1. above.
- (d) In the case of headlamp with a passing beam, one or more driving beams and a front fog lamp:
- (i) the headlamp shall be subjected to the following cycle until the time specified is reached:
15 minutes, passing-beam filament lit;
5 minutes, all filaments lit.
- (ii) if the applicant declares that the headlamp is to be used with only the passing beam lit or only the driving beam(s) ^{3/} lit at a time, the test shall be carried out in accordance with this condition, activating ^{2/} successively the passing beam half of the time and the driving beam(s) for half the time specified in paragraph 1.1. above, while the front fog lamp is subjected to a cycle of 15 minutes off and 5 minutes lit for half of the time and during the operation of the driving beam;
- (iii) if the applicant declares that the headlamp is to be used with only the passing beam lit or only the front fog lamp ^{3/} lit at a time, the test shall be carried out in accordance with this condition, activating ^{2/} successively the passing beam half of the time and the front fog lamp for half of the time specified in paragraph 1.1. above, while the driving beam(s) is(are) subjected to a cycle of 15 minutes off and 5

^{3/} Should two or more lamp filaments be simultaneously lit when headlamp flashing is used, this shall not be considered as being normal use of the filaments simultaneously.

minutes lit for half of the time and during the operation of the passing beam;

- (iv) if the applicant declares that the headlamp is to be used with only the passing beam lit or only the driving beam(s)^{3/} lit or only the front fog lamp^{3/} lit at a time, the test shall be carried out in accordance with this condition, activating^{2/} successively the passing beam one third of the time, the driving beam(s) one third of the time and the front fog lamp for one third of the time specified in paragraph 1.1. above.

1.1.1.2. Test voltage

The voltage shall be adjusted so as to supply 90 per cent of the maximum wattage specified in Regulation No. 37 for the filament lamp(s) used.

The applied wattage shall in all cases comply with the corresponding value of a filament lamp of 12 V rated voltage, except if the applicant for approval specifies that the headlamp may be used at a different voltage.

1.1.2. Test results

1.1.2.1. Visual inspection

Once the headlamp has been stabilized to the ambient temperature, the headlamp lens and the external lens, if any, shall be cleaned with a clean, damp cotton cloth. It shall then be inspected visually; no distortion, deformation, cracking or change in colour of either the headlamp lens or the external lens, if any, shall be noticeable.

1.1.2.2. Photometric test

To comply with the requirements of this Regulation, the photometric values shall be verified in the following points:

For Class B headlamp:

Passing beam: 50R - 50L - B50 - HV.

Driving beam: Point of E_{\max}

For Class C and D headlamp:

Passing beam: 0.86D/3.5R - 0.86D/3.5L - 0.50U/1.5L & 1.5R - HV.

Driving beam: Point of E_{\max}

Another aiming may be carried out to allow for any deformation of the headlamp base due to heat (the change of the position of the cut-off line is covered in paragraph 2. of this annex).

A 10 per cent discrepancy between the photometric characteristics and the values measured prior to the test is permissible including the tolerances of the photometric procedure.

1.2. Dirty headlamp

After being tested as specified in paragraph 1.1. above, the headlamp shall be operated for one hour as described in paragraph 1.1.1., after being prepared as prescribed in paragraph 1.2.1., and checked as prescribed in paragraph 1.1.2.

1.2.1. Preparations of the headlamp

1.2.1.1. Test mixture

1.2.1.1.1. For headlamp with the outside lens in glass:

The mixture of water and a polluting agent to be applied to the headlamp shall be composed of:

9 parts by weight of silica sand with a particle size of 0-100 µm,

1 part by weight of vegetal carbon dust (beechwood) with a particle size of 0-100 µm,

0.2 parts by weight of NaCMC ^{4/}, and
an appropriate quantity of distilled water, with a conductivity of ≤ 1 mS/m.

The mixture must not be more than 14 days old.

1.2.1.1.2. For headlamp with outside lens in plastic material:

The mixture of water and polluting agent to be applied to the headlamp shall be composed of:

9 parts by weight of silica sand with a particle size of 0-100 µm,

1 part by weight of vegetal carbon dust (beechwood) with a particle size of 0-100 µm,

0.2 part by weight of NaCMC ^{4/},

^{4/} NaCMC represents the sodium salt of carboxymethylcellulose, customarily referred to as CMC. The NaCMC used in the dirt mixture shall have a degree of substitution (DS) of 0.6-0.7 and a viscosity of 200-300 cP for a 2 per cent solution at 20 °C.

13 parts by weight of distilled water with a conductivity of ≤ 1 mS/m, and

2 ± 1 parts by weight of surface-actant ^{5/}.

The mixture must not be more than 14 days old.

1.2.1.2. Application of the test mixture to the headlamp

The test mixture shall be uniformly applied to the entire light-emitting surface of the headlamp and then left to dry. This procedure shall be repeated until the illumination value has dropped to 15-20 per cent of the values measured for each following point under the conditions described in this annex:

For Class B headlamp:

Passing beam/driving beam and driving beam only: Point of E_{\max}

Passing beam only: B 50 and 50 V

For Class C and D headlamp:

Passing beam/driving beam and driving beam only: Point of E_{\max}

Passing beam only: 0.50U/1.5L & 1.5R and 0.86D/V

1.2.1.3. Measuring equipment

The measuring equipment shall be equivalent to that used during headlamp approval tests. A standard (étalon) filament lamp shall be used for the photometric verification.

2. TEST FOR CHANGE IN VERTICAL POSITION OF THE CUT-OFF LINE UNDER THE INFLUENCE OF HEAT

This test consists of verifying that the vertical drift of the cut-off line under the influence of heat does not exceed a specified value for an operating passing lamp.

The headlamp tested in accordance with paragraph 1. shall be subjected to the test described in paragraph 2.1., without being removed from or readjusted in relation to its test fixture.

^{5/} The tolerance on quantity is due to the necessity of obtaining a dirt that correctly spreads out on all the plastic lens.

2.1. Test

The test shall be carried out in a dry and still atmosphere at an ambient temperature of $23\text{ °C} \pm 5\text{ °C}$.

Using a mass production filament lamp which has been aged for at least one hour the headlamp shall be operated on passing beam without being dismantled from or readjusted in relation to its test fixture. (For the purpose of this test, the voltage shall be adjusted as specified in paragraph 1.1.1.2.). The position of the cut-off line in its horizontal part (between the vertical lines passing through point 50 L and 50 R for Class B headlamp, 3.5 L and 3.5 R for Class C and D headlamp) shall be verified 3 minutes (r_3) and 60 minutes (r_{60}) respectively after operation.

The measurement of the variation in the cut-off line position as described above shall be carried out by any method giving acceptable accuracy and reproducible results.

2.2. Test results

2.2.1. The result in milliradians (mrad) shall be considered as acceptable for a passing lamp, only when the absolute value $\Delta r_I = |r_3 - r_{60}|$ recorded on the headlamp is not more than 1.0 mrad ($\Delta r_I \leq 1.0\text{ mrad}$).

2.2.2. However, if this value is more than 1.0 mrad but not more than 1.5 mrad ($1.0\text{ mrad} < \Delta r_I \leq 1.5\text{ mrad}$) a second headlamp shall be tested as described in paragraph 2.1. after being subjected three consecutive times to the cycle as described below, in order to stabilize the position of mechanical parts of the headlamp on a base representative of the correct installation on the vehicle:

Operation of the passing beam for one hour, (the voltage shall be adjusted as specified in paragraph 1.1.1.2.),

Period of rest for one hour.

The headlamp type shall be considered as acceptable if the mean value of the absolute values Δr_I measured on the first sample and Δr_{II} measured on the second sample is not more than 1.0 mrad.

$$\frac{\Delta r_I + \Delta r_{II}}{2} \leq 1\text{ mrad}$$

Annex 5

MINIMUM REQUIREMENTS FOR CONFORMITY OF PRODUCTION CONTROL PROCEDURES

1. GENERAL
 - 1.1. The conformity requirements shall be considered satisfied from a mechanical and a geometrical standpoint, if the differences do not exceed inevitable manufacturing deviations within the requirements of this Regulation. This condition also applies to colour.
 - 1.2. With respect to photometric performances, the conformity of mass-produced headlamps shall not be contested if, when testing photometric performances of any headlamp chosen at random and equipped with a standard filament lamp,
 - 1.2.1. Class A headlamp: no measured value deviates unfavourably by more than 20 per cent from the value prescribed in this Regulation.
 - 1.2.2. Class B, C and D headlamp:
 - 1.2.2.1. no measured value deviates unfavourably by more than 20 per cent from the value prescribed in this Regulation. For values in zone III, for Class B headlamp, Zone 1 for Class C and D headlamp, the maximum unfavourable deviation may be respectively:

0.3 lux equivalent 20 per cent
0.45 lux equivalent 30 per cent
 - 1.2.2.2. and if, for the driving beam, HV being situated within the isolux $0.75 E_{\max}$, a tolerance of + 20 per cent for maximum values and - 20 per cent for minimum values is observed for the photometric values at any measuring point specified in paragraphs 6.2.3.2. and 6.3.2.2. of this Regulation.
 - 1.2.3. If the results of the tests described above do not meet the requirements, tests shall be repeated using another standard filament lamp.
 - 1.3. With respect to the verification of the change in vertical position of the cut-off line under the influence of heat, the following procedure shall be applied (Class B, C and D headlamps only):

One of the sampled headlamps shall be tested according to the procedure described in paragraph 2.1. of Annex 4 after being subjected three consecutive times to the cycle described in paragraph 2.2.2. of Annex 4.

The headlamp shall be considered as acceptable if Δr does not exceed 1.5 mrad.

If this value exceeds 1.5 mrad but is not more than 2.0 mrad, a second sample shall be subjected to the test after which the mean of the absolute values recorded on both samples shall not exceed 1.5 mrad.

- 1.4. Headlamps with apparent defects are disregarded.
- 1.5. If, however, for a series of samples vertical adjustment cannot be performed repeatedly to the required position within the allowed tolerances, the quality of cut-off shall be tested on one of the headlamps from the series of samples, according to the procedure described in Annex 9, paragraphs 2. and 4.

2. MINIMUM REQUIREMENTS FOR VERIFICATION OF CONFORMITY BY THE MANUFACTURER

For each type of headlamp the holder of the approval mark shall carry out at least the following tests, at appropriate intervals. The tests shall be carried out in accordance with the provision of this Regulation.

If any sampling shows non-conformity with regard to the type of test concerned, further samples shall be taken and tested. The manufacturer shall take steps to ensure the conformity of the production concerned.

2.1. Nature of tests

Tests of conformity in this Regulation shall cover the photometric characteristics and for Class B, C and D headlamps the verification of the change in vertical position of the cut-off line under influence of heat.

2.2. Methods used in tests

- 2.2.1. Tests shall generally be carried out in accordance with the methods set out in this Regulation.
- 2.2.2. In any test of conformity carried out by the manufacturer, equivalent methods may be used with the consent of the Competent Authority responsible for approval tests. The manufacturer is responsible for proving that the applied methods are equivalent to those laid down in this Regulation.
- 2.2.3. The application of paragraphs 2.2.1. and 2.2.2. requires regular calibration of test apparatus and its correlation with measurement made by a Competent Authority.
- 2.2.4. In all cases the reference methods shall be those of this Regulation, particular for the purpose of administrative verification and sampling.

2.3. Nature of sampling

Samples of headlamps shall be selected at random from the production of a uniform batch. A uniform batch means a set of headlamps of the same type, defined according to the production methods of the manufacturer.

The assessment shall in general cover series production from individual factories. However, a manufacturer may group together records concerning the same type from several factories provided these operate under the same quality system and quality management.

2.4. Measured and recorded photometric characteristics

The sampled headlamps shall be subjected to photometric measurements at the points provided for in the Regulation, the reading being limited at the points:

2.4.1. For Class A headlamps: HV, LH, RH, 12.5L and 12.5R

2.4.2. For Class B headlamps: E_{\max} , HV ^{1/}, in the case of the driving beam, and to the points HV, 50R, 50L, in the case of the passing beam.

2.4.3. For Class C and D headlamps: E_{\max} , HV ^{1/}, in the case of the driving beam, and to the points HV, 0.86D/3.5R, 0.86D/3.5L, in the case of the passing beam.

2.5. Criteria governing acceptability

The manufacturer is responsible for carrying out a statistical study of the test results and for defining, in agreement with the Competent Authority, criteria governing acceptability of his products in order to meet the specification laid down for verification of conformity of products in paragraph 9.1. of this Regulation.

The criteria governing acceptability shall be such that, with a confidence level of 95 per cent, the minimum probability of passing a spot check in accordance with Annex 7 (first sampling) would be 0.95.

^{1/} When the driving beam is reciprocally incorporated with the passing beam, HV in the case of the driving beam shall be the same measuring point as in the case of the passing beam.

Annex 6REQUIREMENTS FOR LAMPS INCORPORATING LENSES OF PLASTIC MATERIAL -
TESTING OF LENS OR MATERIAL SAMPLES AND OF COMPLETE LAMPS

1. GENERAL SPECIFICATIONS
 - 1.1. The samples supplied pursuant to paragraph 2.2.4. of this Regulation shall satisfy the specifications indicated in paragraphs 2.1. to 2.5. below.
 - 1.2. The two samples of complete lamps supplied pursuant to paragraph 2.2.3. of this Regulation and incorporating lenses of plastic material shall, with regard to the lens material, satisfy the specifications indicated in paragraph 2.6. below.
 - 1.3. The samples of lenses of plastic material or samples of material shall be subjected, with the reflector to which they are intended to be fitted (where applicable), to approval tests in the chronological order indicated in table A reproduced in Appendix 1 to this Annex.
 - 1.4. However, if the lamp manufacturer can prove that the product has already passed the tests prescribed in paragraphs 2.1. to 2.5. below, or the equivalent tests pursuant to another regulation, those tests need not be repeated; only the tests prescribed in Appendix 1, table B, shall be mandatory.
2. TESTS
 - 2.1. Resistance to temperature changes
 - 2.1.1. Tests

Three new samples (lenses) shall be subjected to five cycles of temperature and humidity (RH = relative humidity) change in accordance with the following programme:

3 hours at 40 °C ± 2 °C and 85-95 per cent RH;

1 hour at 23 °C ± 5 °C and 60-75 per cent RH;

15 hours at -30 °C ± 2 °C;

1 hour at 23 °C ± 5 °C and 60-75 per cent RH;

3 hours at 80 °C ± 2 °C;

1 hour at 23 °C ± 5 °C and 60-75 per cent RH;

Before this test, the samples shall be kept at $23\text{ °C} \pm 5\text{ °C}$ and 60-75 per cent RH for at least four hours.

Note: The periods of one hour at $23\text{ °C} \pm 5\text{ °C}$ shall include the periods of transition from one temperature to another which are needed in order to avoid thermal shock effects.

2.1.2. Photometric measurements

2.1.2.1. Method

Photometric measurements shall be carried out on the samples before and after the test.

These measurements shall be made using a standard (étalon) lamp, at the following points:

B 50, 50L and 50R for Class B headlamp, 0.86D/3.5R, 0.86D/3.5L, 0.50U/1.5L and 1.5R for Class C and D headlamp for the passing beam or a passing / driving lamp;

E_{\max} for the driving beam of a driving lamp or a passing/driving lamp;

2.1.2.2. Results

The variation between the photometric values measured on each sample before and after the test shall not exceed 10 per cent including the tolerances of the photometric procedure.

2.2. Resistance to atmospheric and chemical agents

2.2.1. Resistance to atmospheric agents

Three new samples (lenses or samples of material) shall be exposed to radiation from a source having a spectral energy distribution similar to that of a black body at a temperature between 5,500 K and 6,000 K. Appropriate filters shall be placed between the source and the samples so as to reduce as far as possible radiations with wave lengths smaller than 295 nm and greater than 2,500 nm. The samples shall be exposed to an energetic illumination of $1,200\text{ W/m}^2 \pm 200\text{ W/m}^2$ for a period such that the luminous energy that they receive is equal to $4,500\text{ MJ/m}^2 \pm 200\text{ MJ/m}^2$. Within the enclosure, the temperature measured on the black panel placed on a level with the samples shall be $50\text{ °C} \pm 5\text{ °C}$. In order to ensure a regular exposure, the samples shall revolve around the source of radiation at a speed between 1 and 5 1/min.

The samples shall be sprayed with distilled water of conductivity lower than 1 mS/m at a temperature of $23\text{ °C} \pm 5\text{ °C}$, in accordance with the following cycle:

spraying: 5 minutes; drying: 25 minutes.

2.2.2. Resistance to chemical agents

After the test described in paragraph 2.2.1. above and the measurement described in paragraph 2.2.3.1. below have been carried out, the outer face of the said three samples shall be treated as described in paragraph 2.2.2.2. with the mixture defined in paragraph 2.2.2.1. below.

2.2.2.1. Test mixture

The test mixture shall be composed of 61.5 per cent n-heptane, 12.5 per cent toluene, 7.5 per cent ethyl tetrachloride, 12.5 per cent trichloroethylene and 6 per cent xylene (volume per cent).

2.2.2.2. Application of the test mixture

Soak a piece of cotton cloth (as per ISO 105) until saturation with the mixture defined in paragraph 2.2.2.1. above and, within 10 seconds, apply it for 10 minutes to the outer face of the sample at a pressure of 50 N/cm^2 , corresponding to an effort of 100 N applied on a test surface of 14 x 14 mm.

During this 10-minute period, the cloth pad shall be soaked again with the mixture so that the composition of the liquid applied is continuously identical with that of the test mixture prescribed.

During the period of application, it is permissible to compensate the pressure applied to the sample in order to prevent it from causing cracks.

2.2.2.3. Cleaning

At the end of the application of the test mixture, the samples shall be dried in the open air and then washed with the solution described in paragraph 2.3. (Resistance to detergents)
 $23\text{ °C} \pm 5\text{ °C}$.

Afterwards the samples shall be carefully rinsed with distilled water containing not more than 0.2 per cent impurities at $23\text{ °C} \pm 5\text{ °C}$ and then wiped off with a soft cloth.

2.2.3. Results

2.2.3.1. After the test of resistance to atmospheric agents, the outer face of the samples shall be free from cracks, scratches, chipping and deformation, and the mean variation in transmission $\Delta t = \frac{T_2 - T_3}{T_2}$, measured on the three samples according to the procedure described in Appendix 2 to this annex shall not exceed 0.020 ($\Delta t_m \leq 0.020$).

2.2.3.2. After the test of resistance to chemical agents, the samples shall not bear any traces of chemical staining likely to cause a variation of flux diffusion, whose mean variation $\Delta d = \frac{T_5 - T_4}{T_2}$, measured on the three samples according to the procedure described in Appendix 2 to this annex shall not exceed 0.020 ($\Delta d_m \leq 0.020$).

2.3. Resistance to detergents and hydrocarbons

2.3.1. Resistance to detergents

The outer face of three samples (lenses or samples of material) shall be heated to $50\text{ °C} \pm 5\text{ °C}$ and then immersed for five minutes in a mixture maintained at $23\text{ °C} \pm 5\text{ °C}$ and composed of 99 parts distilled water containing not more than 0.02 per cent impurities and one part alkylaryl sulphonate.

At the end of the test, the samples shall be dried at $50\text{ °C} \pm 5\text{ °C}$.

The surface of the samples shall be cleaned with a moist cloth.

2.3.2. Resistance to hydrocarbons

The outer face of these three samples shall then be lightly rubbed for one minute with a cotton cloth soaked in a mixture composed of 70 per cent n-heptane and 30 per cent toluene (volume per cent), and shall then be dried in the open air.

2.3.3. Results

After the above two tests have been performed successively, the mean value of the variation in transmission $\Delta t = \frac{T_2 - T_3}{T_2}$, measured on the three samples according to the procedure described in Appendix 2 to this annex shall not exceed 0.010 ($\Delta t_m \leq 0.010$).

2.4. Resistance to mechanical deterioration2.4.1. Mechanical deterioration method

The outer face of the three new samples (lenses) shall be subjected to the uniform mechanical deterioration test by the method described in Appendix 3 to this annex.

2.4.2. Results

After this test, the variations:

$$\text{in transmission: } \Delta t = \frac{T_2 - T_3}{T_2},$$

$$\text{and in diffusion: } \Delta d = \frac{T_5 - T_4}{T_2},$$

shall be measured according to the procedure described in Appendix 2 in the area specified in paragraph 2.2.4.1.1. of this Regulation. The mean value of the three samples shall be such that:

$$\Delta t_m \leq 0.100;$$

$$\Delta d_m \leq 0.050$$

2.5. Test of adherence of coatings, if any2.5.1. Preparation of the sample

A surface of 20 mm x 20 mm in area of the coating of a lens shall be cut with a razor blade or a needle into a grid of squares approximately 2 mm x 2 mm. The pressure on the blade or needle shall be sufficient to cut at least the coating.

2.5.2. Description of the test

Use an adhesive tape with a force adhesion of 2 N/(cm of width) \pm 20 per cent measured under the standardized conditions specified in Appendix 4 to this annex. This adhesive tape, which shall be at least 25 mm wide, shall be pressed for at least five minutes to the surface prepared as prescribed in paragraph 2.5.1.

Then the end of the adhesive tape shall be loaded in such a way that the force of adhesion to the surface considered is balanced by a force perpendicular to that surface. At this stage, the tape shall be torn off at a constant speed of 1.5 m/s \pm 0.2 m/s.

2.5.3. Results

There shall be no appreciable impairment of the gridded area. Impairments at the intersections between squares or at the edges of the cuts shall be permitted, provided that the impaired area does not exceed 15 per cent of the gridded surface.

2.6. Tests of the complete headlamp incorporating a lens of plastic material

2.6.1. Resistance to mechanical deterioration of the lens surface

2.6.1.1. Tests

The lens of lamp sample No. 1 shall be subjected to the test described in paragraph 2.4.1. above.

2.6.1.2. Results

After the test, the results of photometric measurements carried out on the headlamp in accordance with this Regulation shall not exceed by more than 30 per cent the maximum values prescribed at point HV and not be more than 10 per cent below the minimum values prescribed at point 50 L and 50 R for Class B headlamp, 0.86D/3.5R, 0.86D/3.5L for Class C and D headlamp.

2.6.2. Test of adherence of coatings, if any

The lens of lamp sample No. 2 shall be subjected to the test described in paragraph 2.5. above.

3. VERIFICATION OF THE CONFORMITY OF PRODUCTION

3.1. With regard to the materials used for the manufacture of lenses, the lamps of a series shall be recognized as complying with this Regulation if:

3.1.1. After the test for resistance to chemical agents and the test for resistance to detergents and hydrocarbons, the outer face of the samples exhibits no cracks, chipping or deformation visible to the naked eye (see paras. 2.2.2., 2.3.1. and 2.3.2.);

3.1.2. After the test described in paragraph 2.6.1.1., the photometric values at the points of measurement considered in paragraph 2.6.1.2. are within the limits prescribed for conformity of production by this Regulation.

3.2. If the test results fail to satisfy the requirements, the tests shall be repeated on another sample of headlamps selected at random.

Annex 6 - Appendix 1

CHRONOLOGICAL ORDER OF APPROVAL TESTS

A. Tests on plastic materials (lenses or samples of material supplied pursuant to paragraph 2.2.4. of this Regulation).

Samples	Lenses or samples of material						Lenses						
	1	2	3	4	5	6	7	8	9	10	11	12	13
1.1. Limited photometry (para. 2.1.2.)										x	x	x	
1.1.1. Temperature change (para. 2.1.1.)										x	x	x	
1.1.2. Limited photometry (para. 2.1.2.)										x	x	x	
1.2.1. Transmission measurement	x	x	x	x	x	x	x	x	x				
1.2.2. Diffusion measurement	x	x	x				x	x	x				
1.3. Atmospheric agents (para. 2.2.1.)	x	x	x										
1.3.1. Transmission measurement	x	x	x										
1.4. Chemical agents (para. 2.2.2.)	x	x	x										
1.4.1. Diffusion measurement	x	x	x										
1.5. Detergents (para. 2.3.1.)				x	x	x							
1.6. Hydrocarbons (para. 2.3.2.)				x	x	x							
1.6.1. Transmission measurement				x	x	x							
1.7. Deterioration (para. 2.4.1.)							x	x	x				
1.7.1. Transmission measurement							x	x	x				
1.7.2. Diffusion measurement							x	x	x				
1.8. Adherence (para. 2.5.)													x

B. Tests on complete headlamps (supplied pursuant to paragraph 2.2.3. of this Regulation).

Tests	Complete headlamp	
	Sample No.	
	1	2
2.1. Deterioration (para. 2.6.1.1.)	x	
2.2. Photometry (para. 2.6.1.2.)	x	
2.3. Adherence (para. 2.6.2.)		x

Annex 6 - Appendix 2

METHOD OF MEASUREMENT OF THE DIFFUSION AND TRANSMISSION OF LIGHT

1. EQUIPMENT (see figure)

The beam of a collimator K with a half divergence $\beta/2 = 17.4 \times 10^4$ rd is limited by a diaphragm D_T with an opening of 6 mm against which the sample stand is placed.

A convergent achromatic lens L_2 , corrected for spherical aberrations links the diaphragm D_T with the receiver R; the diameter of the lens L_2 shall be such that it does not diaphragm the light diffused by the sample in a cone with a half top angle of $\beta/2 = 14^\circ$.

An annular diaphragm D_D , with angles $\alpha_0/2 = 1^\circ$ and $\alpha_{\max}/2 = 12^\circ$ is placed in an image focal plane of the lens L_2 .

The non-transparent central part of the diaphragm is necessary in order to eliminate the light arriving directly from the light source. It shall be possible to remove the central part of the diaphragm from the light beam in such a manner that it returns exactly to its original position.

The distance $L_2 D_T$ and the focal length F_2 ^{1/} of the lens L_2 shall be so chosen that the image of D_T completely covers the receiver R.

When the initial incident flux is referred to 1,000 units, the absolute precision of each reading shall be better than 1 unit.

^{1/} For L_2 it is recommended to use a focal distance of about 80 mm.

2. MEASUREMENTS

The following readings shall be taken:

Reading	With sample	With central part of D_D	Quantity represented
T_1	no	no	Incident flux in initial reading
T_2	yes (before test)	no	Flux transmitted by the new material in a field of 24°
T_3	yes (after test)	no	Flux transmitted by the tested material in a field of 24°
T_4	yes (before test)	yes	Flux diffused by the new material
T_5	yes (after test)	yes	Flux diffused by the tested material

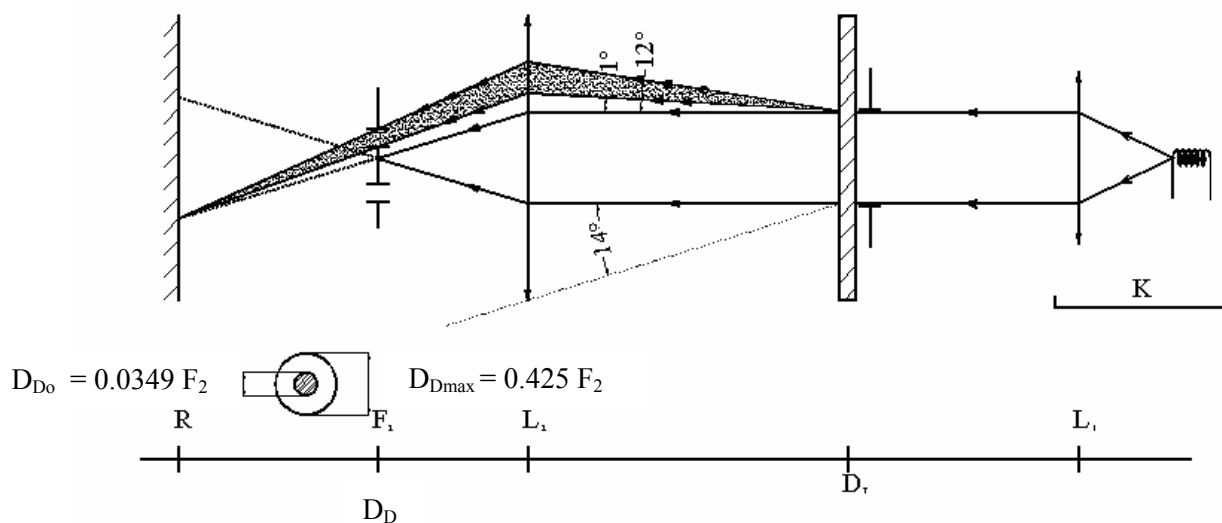

Annex 6 - Appendix 3

SPRAY TESTING METHOD

1. Test equipment

1.1. Spray gun

The spray gun used shall be equipped with a nozzle 1.3 mm in diameter allowing a liquid flow rate of 0.24 ± 0.02 l/minute at an operating pressure of 6.0 bars $-0/+0.5$ bar.

Under these operation conditions the fan pattern obtained shall be $170 \text{ mm} \pm 50 \text{ mm}$ in diameter on the surface exposed to deterioration, at a distance of $380 \text{ mm} \pm 10 \text{ mm}$ from the nozzle.

1.2. Test mixture

The test mixture shall be composed of:

- (a) Silica sand of hardness 7 on the Mohr scale, with a grain size between 0 and 0.2 mm and an almost normal distribution, with an angular factor of 1.8 to 2;
- (b) Water of hardness not exceeding 205 g/m^3 for a mixture comprising 25 g of sand per litre of water.

2. Test

The outer surface of the lamp lenses shall be subjected once or more than once to the action of the sand jet produced as described above. The jet shall be sprayed almost perpendicular to the surface to be tested.

The deterioration shall be checked by means of one or more samples of glass placed as a reference near the lenses to be tested. The mixture shall be sprayed until the variation in the diffusion of light on the sample or samples measured by the method described in Appendix 2, is such that:

$$\Delta d = \frac{T_5 - T_4}{T_2} = 0.0250 \pm 0.0025$$

Several reference samples may be used to check that the whole surface to be tested has deteriorated homogeneously.

Annex 6 - Appendix 4

ADHESIVE TAPE ADHERENCE TEST

1. PURPOSE

This method allows to determine under standard conditions the linear force of adhesion of an adhesive tape to a glass plate.

2. PRINCIPLE

Measurement of the force necessary to unstick an adhesive tape from a glass plate at an angle of 90°.

3. SPECIFIED ATMOSPHERIC CONDITIONS

The ambient conditions shall be at 23 °C ± 5 °C and 65 ± 15 per cent RH.

4. TEST PIECES

Before the test, the sample roll of adhesive tape shall be conditioned for 24 hours in the specified atmosphere (see para. 3. above).

Five test pieces each 400 mm long shall be tested from each roll. These test pieces shall be taken from the roll after the first three turns were discarded.

5. PROCEDURE

The test shall be under the ambient conditions specified in paragraph 3.

Take the five test pieces while unrolling the tape radially at a speed of approximately 300 mm/s, then apply them within 15 seconds in the following manner:

Apply the tape to the glass plate progressively with a slight length-wise rubbing movement of the finger, without excessive pressure, in such a manner as to leave no air bubble between the tape and the glass plate.

Leave the assembly in the specified atmospheric conditions for 10 minutes.

Unstick about 25 mm of the test piece from the plate in a plane perpendicular to the axis of the test piece. Fix the plate and fold back the free end of the tape at 90°. Apply force in such a manner that the separation line between the tape and the plate is perpendicular to this force and perpendicular to the plate.

Pull to unstick at a speed of 300 mm/s ± 30 mm/s and record the force required.

6. RESULTS

The five values obtained shall be arranged in order and the median value taken as a result of the measurement. This value shall be expressed in Newtons per centimetre of width of the tape.

Annex 7

MINIMUM REQUIREMENTS FOR SAMPLING BY AN INSPECTOR

1. GENERAL

- 1.1. The conformity requirements shall be considered satisfied from a mechanical and a geometrical standpoint in accordance with the requirements of this Regulation, if any, if the differences do not exceed inevitable manufacturing deviations. This condition also applies to colour.
- 1.2. With respect to photometric performances, the conformity of mass-produced headlamps shall not be contested if, when testing photometric performances of any headlamp chosen at random and equipped with a standard filament lamp:
 - 1.2.1. Class A headlamps: no measured value deviates unfavourably by more than 20 per cent from the value prescribed in this Regulation.
 - 1.2.2. Class B, C and D headlamps:
 - 1.2.2.1. no measured value deviates unfavourably by more than 20 per cent from the value prescribed in this Regulation. For values in zone III for Class B headlamp, zone I for Class C and D headlamp, the maximum unfavorable deviation may be respectively:

0.3 lux equivalent 20 per cent
0.45 lux equivalent 30 per cent
 - 1.2.2.2. and if for the driving beam, HV being situated within the isolux $0.75 E_{\max}$, a tolerance of + 20 per cent for maximum values and - 20 per cent for minimum values is observed for the photometric values at any measuring point specified in paragraphs 6.2.3.2. and 6.3.2.2. of this Regulation.
 - 1.2.3. If the results of the tests described above do not meet the requirements, tests shall be repeated using another standard filament lamp.
 - 1.2.4. Headlamps with apparent defects are disregarded.
- 1.3. If, however, for a series of samples vertical adjustment cannot be performed repeatedly to the required position within the allowed tolerances, the quality of cut-off shall be tested on one of the headlamps from the series of samples, according to the procedure described in Annex 9, paragraphs 2. and 4.

2. FIRST SAMPLING

In the first sampling four headlamps are selected at random. The first sample of two is marked A, the second sample of two is marked B.

2.1. The conformity is not contested

2.1.1. Following the sampling procedure shown in Figure 1 of this annex the conformity of mass-produced headlamps shall not be contested if the deviations of the measured values of the headlamps in the unfavourable directions are:

2.1.1.1. sample A

A1: one headlamp		0 per cent
one headlamp	not more than	20 per cent
A2: both headlamps	more than	0 per cent
But	not more than	20 per cent
go to sample B		

2.1.1.2. sample B

B1: both headlamps		0 per cent
--------------------	--	------------

2.2. The conformity is contested

2.2.1. Following the sampling procedure shown in Figure 1 of this annex the conformity of mass-produced headlamps shall be contested and the manufacturer requested to make his production meet the requirements (alignment) if the deviations of the measured values of the headlamps are:

2.2.1.1. sample A

A3: one headlamp	not more than	20 per cent
one headlamp	more than	20 per cent
but	not more than	30 per cent

2.2.1.2. sample B

B2: in the case of A2		
one headlamp	more than	0 per cent
but	not more than	20 per cent
one headlamp	not more than	20 per cent
B3: in the case of A2		
one headlamp		0 per cent
one headlamp	more than	20 per cent
but	not more than	30 per cent

2.3. Approval withdrawn

Conformity shall be contested and paragraph 11. applied if, following the sampling procedure shown in Figure 1 of this annex, the deviations of the measured values of the headlamps are:

2.3.1. sample A

A4: one headlamp	not more than	20 per cent
one headlamp	more than	30 per cent

A5: both headlamps	more than	20 per cent
--------------------	-----------	-------------

2.3.2. sample B

B4: in the case of A2		
one headlamp	more than	0 per cent
but	not more than	20 per cent
one headlamp	more than	20 per cent

B5: in the case of A2		
both headlamps	more than	20 per cent

B6: in the case of A2		
one headlamp		0 per cent
one headlamp	more than	30 per cent

3. REPEATED SAMPLING

In the case of A3, B2, B3 a repeated sampling, third sample C of two headlamps, selected from stock manufactured after alignment, is necessary within two months' time after the notification.

3.1. The conformity is not contested

3.1.1. Following the sampling procedure shown in Figure 1 of this annex the conformity of mass-produced headlamps shall not be contested if the deviations of the measured values of the headlamps are:

3.1.1.1. sample C

C1: one headlamp		0 per cent
one headlamp	not more than	20 per cent

- | | | | |
|--|--------------------|---------------|-------------|
| | C2: both headlamps | more than | 0 per cent |
| | but | not more than | 20 per cent |
| | go to sample D | | |
- 3.1.1.2. sample D
- | | | | |
|--|-----------------------|--|------------|
| | D1: in the case of C2 | | |
| | both headlamps | | 0 per cent |
- 3.2. The conformity is contested
- 3.2.1. Following the sampling procedure shown in Figure 1 of this annex the conformity of mass-produced headlamps shall be contested and the manufacturer requested to make his production meet the requirements (alignment) if the deviations of the measured values of the headlamps are:
- 3.2.1.1. sample D
- | | | | |
|--|-----------------------|---------------|-------------|
| | D2: in the case of C2 | | |
| | one headlamp | more than | 0 per cent |
| | but | not more than | 20 per cent |
| | one headlamp | not more than | 20 per cent |
- 3.3. Approval withdrawn
- Conformity shall be contested and paragraph 11. applied if, following the sampling procedure shown in Figure 1 of this annex, the deviations of the measured values of the headlamps are:
- 3.3.1. sample C
- | | | | |
|--|--------------------|---------------|-------------|
| | C3: one headlamp | not more than | 20 per cent |
| | one headlamp | more than | 20 per cent |
| | C4: both headlamps | more than | 20 per cent |
- 3.3.2. sample D
- | | | | |
|--|-----------------------|----------------|-------------|
| | D3: in the case of C2 | | |
| | one headlamp | 0 or more than | 0 per cent |
| | one headlamp | more than | 20 per cent |

Figure 1

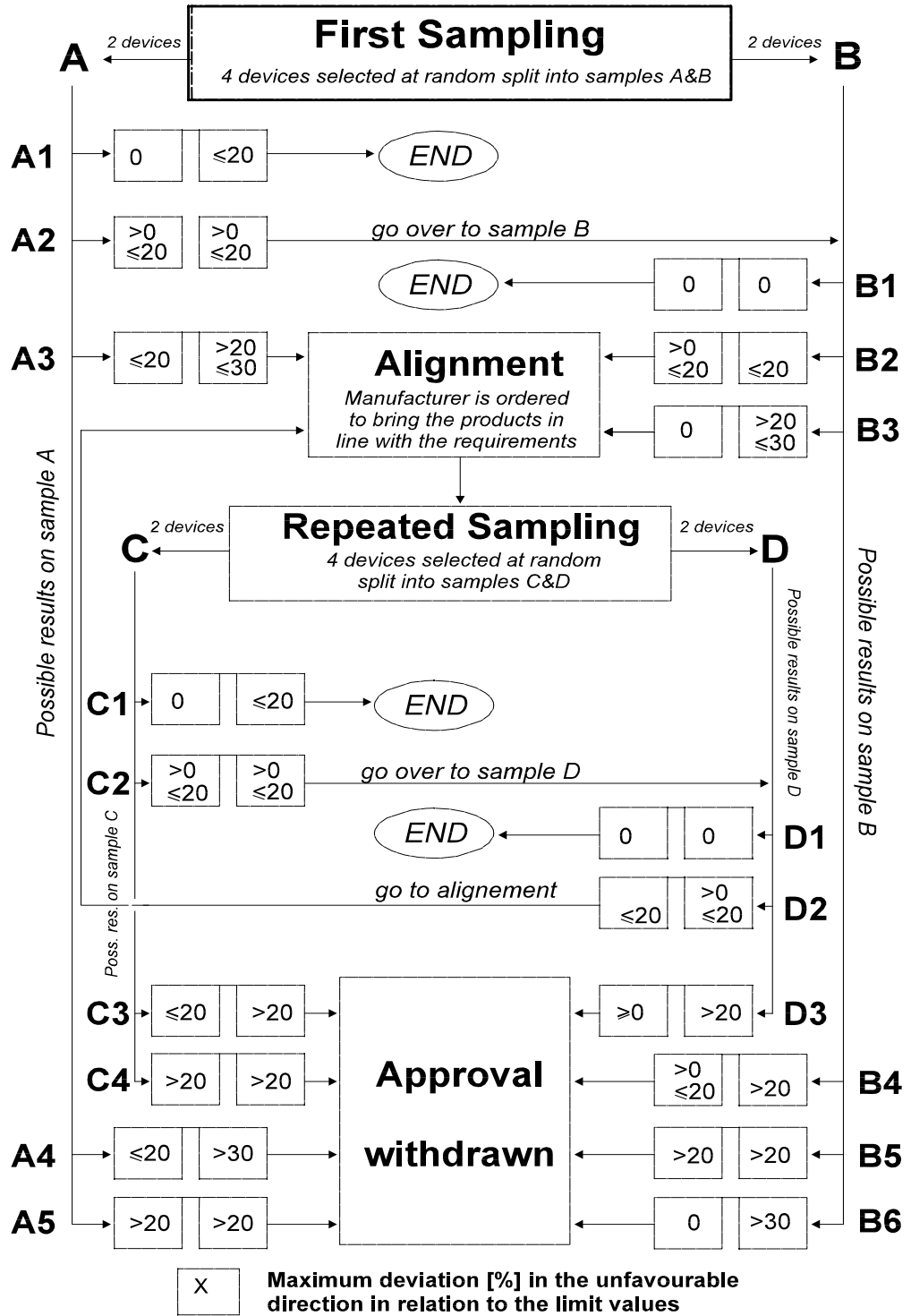

Annex 8

OVERVIEW OF OPERATIONAL PERIODS CONCERNING TEST FOR STABILITY OF PHOTOMETRIC PERFORMANCE

- Abbreviations: P: passing beam lamp
 D: driving beam lamp (D₁ + D₂ means two driving beams)
 F: front fog lamp
 - - - - - : means a cycle of 15 minutes off and 5 minutes lit.

All following grouped headlamps and front fog lamps together with the added class B marking symbols are given as examples and are not exhaustive.

1. P or D or F (C-BS or R-BS or B)

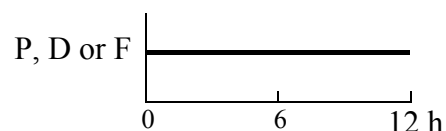

2. P+D (CR-BS) or P+D₁+D₂ (CR-BS R-BS)

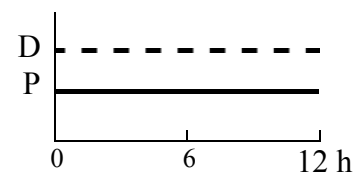

3. P+D (C/R-BS) or P+D₁+D₂ (C/R-BS R-BS)

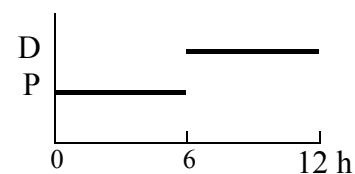

4. P+F (C-BS B)

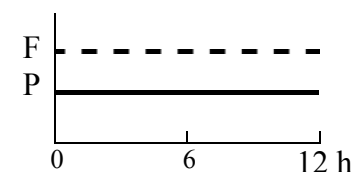

5. P+F (C-BS B/) or C-BS/B

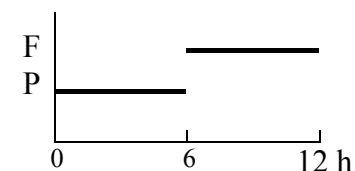

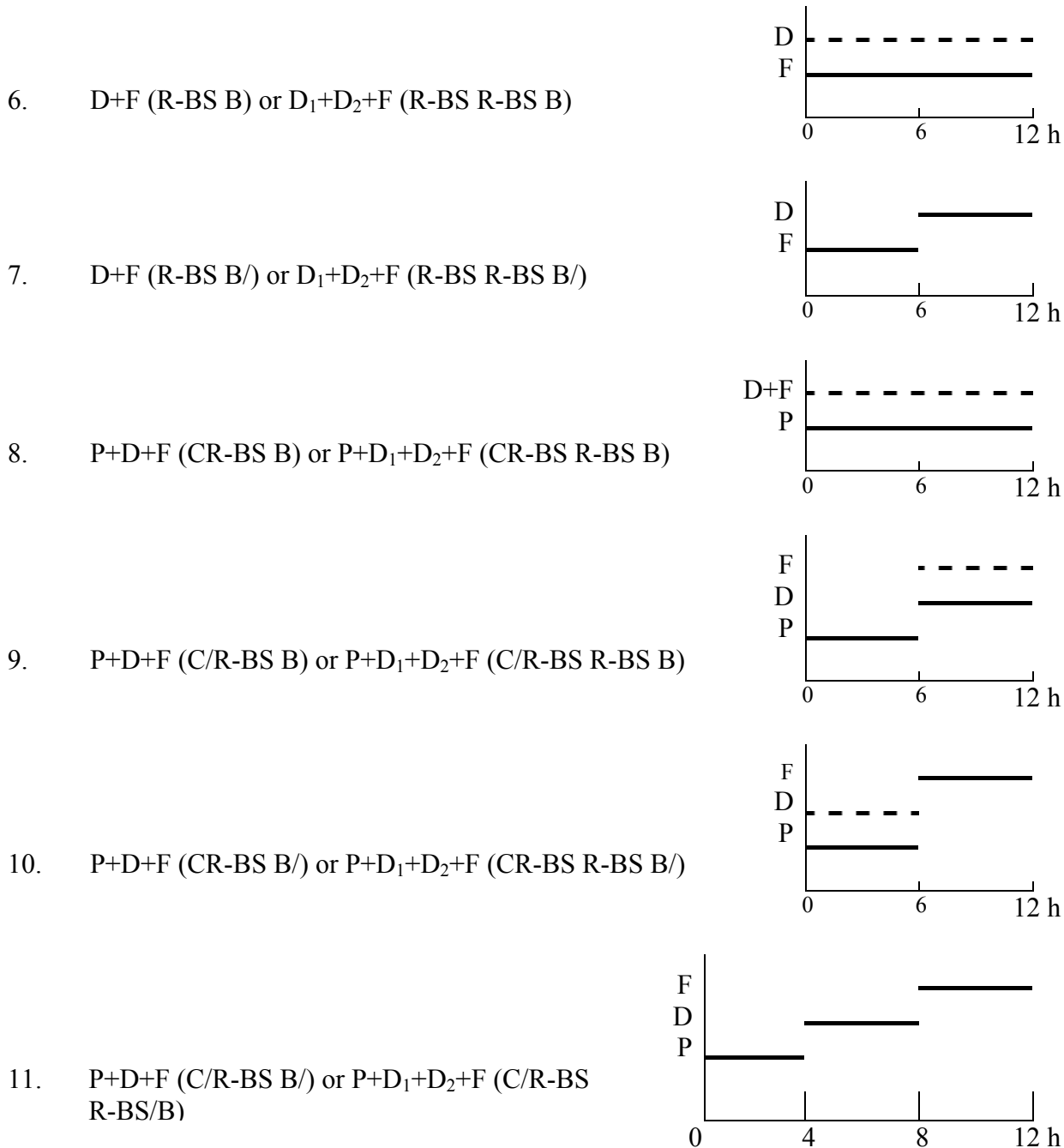

Annex 9

DEFINITION AND SHARPNESS OF THE "CUT-OFF" LINE FOR SYMMETRICAL PASSING-BEAM HEADLAMPS AND AIMING PROCEDURE BY MEANS OF THIS CUT-OFF LINE

- 1.
- 2.
- 3.
- 4.
- 5.
- 6.
- 7.
- 8.
- 9.

1. General:

1.1. The luminous intensity distribution of the symmetrical passing-beam headlamps shall incorporate a "cut-off" line which enables the symmetrical passing-beam headlamp to be adjusted correctly for the photometric measurements and for the aiming on the vehicle. The characteristics of the "cut-off" line shall comply with the requirements set out in paragraphs 2. to 4. below:

2. Shape of the cut-off line:

2.1. For visual adjustment of the symmetrical passing-beam headlamp the cut-off line shall provide: a horizontal line for vertical adjustment of the symmetrical passing-beam headlamp extending to either side of the V-V-line (see Figure 1) as specified in paragraph 6.2.1. of this Regulation.

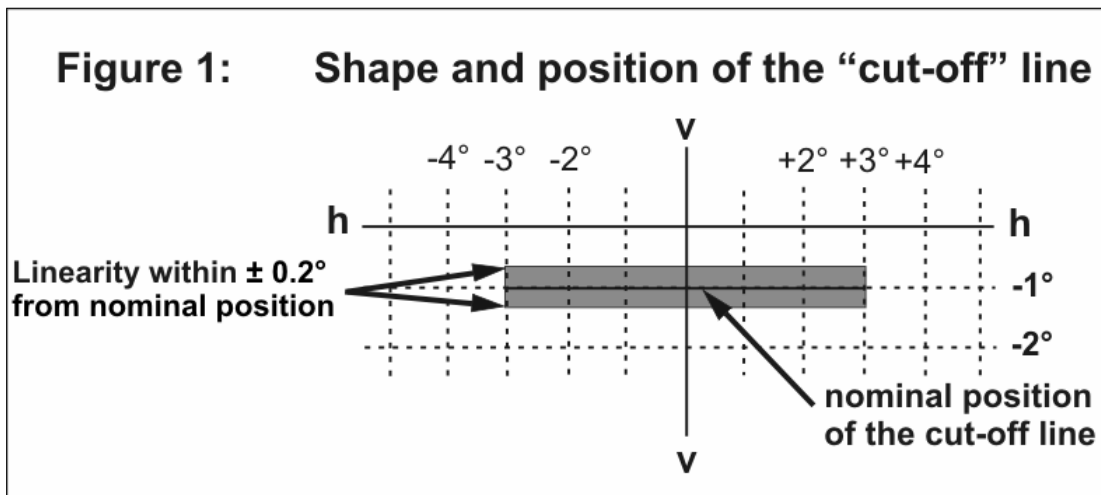

- 10.
- 11.
- 12.
- 13.
- 14.
- 15.
- 16.

3. Adjustment of the symmetrical passing-beam headlamp:

3.1. Horizontal adjustment: The beam with the "cut-off" line shall be so positioned that the projected beam pattern appears approximately symmetrical to the V-V-line.

3.2. Vertical adjustment: After horizontal adjustment of the symmetrical passing-beam headlamp according to paragraph 3.1. above, the vertical adjustment shall be performed in such a way that the beam with its cut-off line is moved upwards from the lower position until the cut-off line is situated at nominal vertical position. For nominal vertical adjustment the cut-off line is positioned on the V-V-line at 1° below the H-H-line.

If the horizontal part is not straight but slightly curved or inclined, the cut-off line shall not exceed the vertical range formed by two horizontal lines which are situated from 3° left to 3° right of the V-V-line at 0.2° for class B and 0.3° for class A, C and D head lamps above and below the nominal position of the cut-off (see Figure 1).

17. 3.3. When the vertical adjustments of three different individuals differs by more than 0.2° for class B and 0.3° for class A, C and D head lamps, the horizontal part of the cut-off line is assumed not to provide sufficient linearity or sharpness for performing visual adjustment. In this case the quality of cut-off shall be tested instrumentally for compliance with requirements as follows.

18.

19. 4. Measurement of the quality of cut-off:

4.1. Measurements shall be performed by vertically scanning through the horizontal part of the cut-off line in angular steps not exceeding 0.05°

(a) at either a measurement distance of 10 m and a detector with a diameter of approximately 10 mm.

(b) or at a measurement distance of 25 m and a detector with a diameter of approximately 30 mm.

The measurement of the cut-off quality shall be considered acceptable if the requirements of the paragraph 4.1.2. of this annex shall comply with at least one measurement at 10 m or 25 m.

The measuring distance at which the test was determined shall be noted down in paragraph 9., Annex 1 "Communication form" of this Regulation.

20.

21. The scanning is performed from its lower position upwards through the cut-off line along the vertical lines at -3°, -1.5°, +1.5° and +3° from the V-V-line. When so measured, the quality of the cut-off line shall meet the following requirements:

22.

23. 4.1.1. Not more than one cut-off line shall be visible.^{43/}

24.

25. 4.1.2. Sharpness of cut-off: if scanned vertically through the horizontal part of the cut-off line along the ± 2.5 -lines, the maximum value measured for:

26.

$$27. \quad G = (\log E_V - \log E_{(V+0.1^\circ)})$$

28.

29. is called the sharpness factor G of the cut-off line. The value of G shall not be less than 0.13 for class B and 0.08 for classes A, C and D.

30.

31. 4.1.3. Linearity: the part of the cut-off line which serves for vertical adjustment shall be horizontal from 3°L to 3°R of the V-V-line. This requirement is deemed to be met if the vertical positions of the inflection points according to

^{43/} This paragraph will be amended, if an objective test method is available.

paragraph 3.2. above at 3° left and right of the V-V-line do not differ by more than 0.2° for class B and 0.3° for class A, C and D head lamps from the nominal position at the V-V-line.

32.

33.

5. Instrumental vertical adjustment: if the cut-off line complies with the above quality requirements, the vertical beam adjustment can be performed instrumentally. For this purpose the inflection point where $d^2(\log E) / dv^2 = 0$ is positioned on the V-V-line in its nominal position below the H-H-line. The movement for measuring and adjusting the cut-off line shall be upwards from below the nominal position.

- - - - -

Appendix H*

The title of the Regulation, amend to read:

"UNIFORM PROVISIONS CONCERNING THE APPROVAL OF MOTOR VEHICLE HEADLAMPS EMITTING AN ASYMMETRICAL PASSING BEAM OR A DRIVING BEAM OR BOTH AND EQUIPPED WITH FILAMENT LAMPS **AND/OR LED MODULES**"

The list of contents, the annexes, amend to read:

"

Annex 8 - Overview of operational periods concerning tests for stability of photometric performance

Annex 9 - **Requirements for LED modules and headlamps including LED modules**

Annex 10 - **A general illustration for principal passing beam and beam contributors and correlated light source options"**

Text of the Regulation,

Paragraph 1.3.7., amend to read:

"1.3.7. The category of filament lamp used **and/or the light source module specific identification code(s).**"

Paragraph 2.1.5., amend to read:

"2.1.5. the category of the filament lamp(s) used, as listed in Regulation No. 37 **and/or the light source module specific identification code(s) for LED modules, if available.**"

Paragraph 2.2.1., amend to read:

"2.2.1. drawings in triplicate in sufficient detail to permit identification of the type and representing a frontal view of the headlamp, with details of lens ribbing if any, and the cross-section. The drawings shall indicate the space(s) reserved for the

* ECONOMIC COMMISSION FOR EUROPE
INLAND TRANSPORT COMMITTEE
World Forum for Harmonization of Vehicle Regulations
Working Party on Lighting and Light-Signalling
LIGHT-EMITTING DIODE (LED) MODULES FOR ROAD ILLUMINATION DEVICES
Regulation No. 112 (Headlamps emitting an asymmetrical passing beam)
Proposal for draft amendments to Regulation No. 112
Submitted by the expert from the Working Party "Brussels 1952"

The text reproduced below was prepared by the expert from the Working Party "Brussels 1952" (GTB) in order to introduce into the Regulation provisions for light-emitting diode (LED) modules. The proposal consolidates and supersedes ECE/TRANS/WP.29/GRE/2006/44. The modifications to the current text of the Regulation (up to Supplement 7 to the original version) are marked in bold or strikethrough characters.
ECE/TRANS/WP.29/GRE/2007/12

approval mark **and in case of LED module(s) also the space reserved for the specific identification code(s) of the module(s);"**

Paragraph 2.2.2., amend to read:

"2.2.2. a brief technical description including, in the case where headlamps are used to produce bend lighting, the extreme positions according to paragraph 6.2.9. below.
In the case of LED module(s) this shall include:

- (a) **a brief technical specification of the LED module(s);**
- (b) **a drawing with dimensions and the basic electrical and photometric values and the objective luminous flux;**
- (c) **in case of electronic light source control gear, information on the electrical interface necessary for approval testing;"**

Paragraph 2.2.4.1., amend to read:

"2.2.4.1. **fourteen** lenses;"

Paragraph 2.2.4.1.1., amend to read:

"2.2.4.1.1. **ten** of these lenses may be replaced by **ten** samples of material at least 60 x 80 mm in size, having a flat or convex outer surface and a substantially flat area (radius of curvature not less than 300 mm) in the middle measuring at least 15 x 15 mm;"

Insert new paragraphs 2.2.5. and 2.2.6., to read:

"2.2.5. **For testing the ultraviolet (UV)-resistance of light transmitting components made of plastic material against UV radiation of LED modules inside the headlamp:**

2.2.5.1. **one sample of each of the relevant material as being used in the headlamp or one headlamp sample containing these. Each material sample shall have the same appearance and surface treatment, if any, as intended for use in the headlamp to be approved;**

2.2.5.2. **the UV-resistance testing of internal materials to light source radiation is not necessary if no LED modules other than low-UV-types as specified in Annex 9 of this Regulation are being applied or if provisions are taken, to shield the relevant headlamp components from UV radiation, e.g. by glass filters.**

2.2.6. **One electronic light source control gear, if applicable."**

Paragraph 3.3., amend to read:

"3.3. Headlamps designed to satisfy the requirements both of right-hand and of left-hand traffic shall bear markings indicating the two settings of the optical unit **or LED module** on the vehicle or position for left-hand traffic."

Insert new paragraphs 3.4. to 3.6., to read:

"3.4. **In the case of lamps with LED module(s), the lamp shall bear the marking of the rated voltage and rated wattage and the light source module specific identification code.**

3.5. LED module(s) submitted along with the approval of the lamp:

3.5.1. shall bear the trade name or mark of the applicant. This marking shall be clearly legible and indelible;

3.5.2. shall bear the specific identification code of the module. This marking shall be clearly legible and indelible.

This specific identification code shall comprise the starting letters "MD" for "MODULE" followed by the approval marking without the circle as prescribed in paragraph 4.2.1. below and in the case several non identical light source modules are used, followed by additional symbols or characters. This specific identification code shall be shown in the drawings mentioned in paragraph 2.2.1. above. The approval marking does not have to be the same as the one on the lamp in which the module is used, but both markings shall be from the same applicant.

3.6. If an electronic light source control gear which is not part of a LED module is used to operate a LED module(s), it shall be marked with its specific identification code(s), the rated input voltage and wattage."

Paragraph 4.2.2.2., amend to read:

"4.2.2.2. on headlamps designed to meet the requirements of both traffic systems by means of an appropriate adjustment of the setting of the optical unit or the filament lamp **or LED module(s)**, a horizontal arrow with a head on each end, the heads pointing respectively to the left and to the right;"

Paragraph 4.2.3.1., amend to read:

"4.2.3.1. on headlamps meeting the requirements of this Regulation which are so designed that the filament **or LED module(s) producing the principal** passing beam shall not be lit simultaneously with that of any other lighting function with which it may be reciprocally incorporated: an oblique stroke (/) shall be placed behind the passing lamp symbol in the approval mark."

Paragraph 4.2.3.2., amend to read:

"4.2.3.2. on headlamps **equipped with filament lamps and** meeting the requirements of Annex 4 to this Regulation only when supplied with a voltage of 6 V or 12 V, a

symbol consisting of the number 24 crossed out by an oblique cross (x), shall be placed near the filament lamp holder."

Paragraph 5.2.1., amend to read:

"5.2.1. Headlamps shall be fitted with by other means.

Where a headlamp providing a **principal** passing beam and a headlamp providing a driving beam, each equipped with its own filament lamp **or LED module(s)**, are assembled to form a composite unit the adjusting device shall enable each optical system individually to be duly adjusted."

Paragraph 5.3., amend to read (including the deletion of the reference to footnote 7/ and footnote 7/):

"5.3. The headlamp shall be equipped with:

5.3.1. filament lamp(s) approved according to Regulation No. 37. Any Regulation No. 37 filament lamp may be used, provided that no restriction on the application is made in the table of contents of Regulation No. 37."

Paragraph 5.4., renumber as paragraph 5.3.1.1. and amend to read (the reference to footnote 8/ and footnote 8/ renumber as footnote 7/):

"**5.3.1.1.** The components by which a filament lamp is fixed to the reflector shall be so made that, even in darkness, the filament lamp can be fixed in no position but the correct one. 7/"

Paragraph 5.5., renumber as paragraph 5.3.1.2. and amend to read:

"**5.3.1.2.** The filament lamp holder shall conform to the characteristics given in IEC Publication 60061-2, ~~third edition, 1969~~. The holder data sheet relevant to the category of filament lamp used, applies."

Insert new paragraphs 5.3.2. to 5.3.2.3., to read:

"**5.3.2.** **and/or LED module(s):**

5.3.2.1. **electronic light source control gear(s), if applicable, shall be considered to be part of the headlamp; they may be part of the LED module(s);**

5.3.2.2. **the headlamp, if equipped with LED modules, and the LED module(s) themselves shall comply with the relevant requirements specified in Annex 9 of this Regulation. The compliance with the requirements shall be tested.**

5.3.2.3. **The total objective luminous flux of all LED modules producing the principal passing beam and measured as described in paragraph 5. of Annex 9 shall be equal or greater than 1,000 lumens."**

Paragraph 5.6., renumber as paragraph 5.4. and amend to read:

"**5.4.** Headlamps designed to satisfy the requirements both of right-hand and of left-hand traffic may be adapted for traffic on a given side of the road either by an appropriate initial setting when fitted on the vehicle or by selective setting by the user. Such initial or selective setting may consist, for example, of fixing either the optical unit at a given angle on the vehicle or the filament lamp **or LED module(s) producing the principal passing beam** at a given angle/position in relation to the optical unit. In all cases, only two different and clearly distinct settings, one for right-hand and one for left-hand traffic, shall be possible, and the design shall preclude inadvertent shifting from one setting to the other or setting in an intermediate position. Where two different setting positions are provided for the filament lamp **or LED module(s) producing the principal passing beam**, the components for attaching the filament lamp **or LED module(s) producing the principal passing beam** to the reflector must be so designed and made that, in each of its two settings, **this filament lamp or LED module(s)** will be held in position with the precision required for headlamps designed for traffic on only one side of the road. Conformity with the requirements of this paragraph shall be verified by visual inspection and, where necessary, by a test fitting."

Paragraph 5.7., renumber as paragraph 5.5.

Paragraph 5.8., renumber as paragraph 5.6. and amend to read:

"**5.6.** **Light transmitting components made of plastic material shall be tested** according to the requirements of Annex 6."

Paragraphs 5.9. to 5.9.4., renumber as paragraphs 5.7. to 5.7.4.

Insert a new paragraph 5.8., to read:

"**5.8.** **In case of a passing beam headlamp incorporating a light source or LED module(s) producing the principal passing beam and having a total objective luminous flux which exceeds 2,000 lumen a reference shall be made in item 9. of the communication form in Annex 1. The objective luminous flux of LED modules shall be measured as described in paragraph 5. of Annex 9.**"

Paragraph 6.1.1., amend to read:

"6.1.1. Headlamps shall be so made that they give adequate illumination without dazzle when emitting the passing beam, and good illumination when emitting the driving beam. **Bend lighting may be produced by activating one additional filament light source or one or more LED module(s) being part of the passing beam headlamp.**"

Paragraphs 6.1.3. and 6.1.4., amend to read:

"6.1.3. **Apart from LED module(s)**, the headlamps shall be checked by means of an uncoloured standard (étalon) filament lamp designed for a rated voltage of 12 V. During the checking of the headlamp, the voltage at the terminals of the filament lamp shall be regulated so as to obtain the reference luminous flux as indicated **for each filament lamp** at the relevant data sheet of Regulation No. 37. **The headlamp shall be considered acceptable if it meets the requirements of paragraph 6. with at least one standard (étalon) filament lamp, which may be submitted with the headlamp.**

6.1.4. **LED module(s) shall be measured at 6.3 V, 13.2 V or 28.0 V respectively, if not otherwise specified within this Regulation. LED module(s) operated by an electronic light source control gear, shall be measured as specified by the applicant.**

The values obtained by the LED module(s) shall be multiplied by a factor of 0.7 prior to check for compliance."

Insert a new paragraph 6.1.5., to read:

"6.1.5. **In the case of headlamps equipped with LED module(s) and filament lamps, the part of the headlamp with filament lamp(s) shall be tested alone according to paragraph 6.1.3. and the part of the headlamp with LED module(s) shall be evaluated alone according to the provisions of paragraph 6.1.4. and then added to the previous result obtained from the filament lamp(s) tested."**

Paragraph 6.2.2.1., the reference to footnote 9/ and footnote 9/, renumber as footnote 8/.

Paragraph 6.2.2.3., the reference to footnote 10/ and footnote 10/, renumber as footnote 9/.

Paragraph 6.2.3., the reference to footnote 11/ and footnote 11/, renumber as footnote 10/.

Paragraph 6.2.4., the reference to footnote 12/ and footnote 12/, renumber as footnote 11/.

Paragraph 6.2.7., the reference to footnote 13/ and footnote 13/, renumber as footnote 12/.

Paragraphs 6.2.8. and 6.2.9., amend to read:

"6.2.8. Headlamps designed to meet the requirements of both right-hand and left-hand traffic must, in each of the two setting positions of the optical unit **or LED module(s) producing the principal passing beam** or of the filament lamp, meet the requirements set forth above for the corresponding direction of traffic.

6.2.9. The requirements in paragraph 6.2.5. above shall also apply to headlamps designed to provide bend lighting and/or that include the additional light source **or LED module(s)** referred to in paragraph 6.2.10.2. In the case by more than 0.2°."

Paragraph 6.2.9.1.3., amend to read:

"6.2.9.1.3. means of one additional **filament** light source **or one or more LED module(s)** without moving horizontally the kink of the elbow of the cut-off, measurements shall be carried out with this light source **or LED module(s)** activated."

Paragraphs 6.2.10. to 6.2.10.3., amend to read:

"6.2.10. Only one **filament** light source **or one or more LED module(s)** are permitted for **the principal** passing beam. Additional light sources **or LED modules** are permitted **only** as follows (see **Annex 10**):

6.2.10.1. one additional light source according to Regulation No. 37 **or one or more additional LED module(s)** may be used inside the passing beam headlamp to contribute to bend lighting;

6.2.10.2. one additional light source according to Regulation No. 37 **or one or more LED module(s)**, inside the passing beam headlamp, may be used for the purposes of generating infrared radiation. It/**they** shall only be activated at the same time as the principal light source **or LED module(s)**. In the event that the principal light source **or (one of) the principal LED module(s)** fail, this additional light source **or LED module(s)** shall be automatically switched off;

6.2.10.3. in the event of failure of an additional **filament** light source **or one or more additional LED module(s)**, the headlamp shall continue to fulfil the requirements of the passing beam."

Paragraph 6.3.2., amend to read:

"6.3.2. **Independent on whether LED module(s) or filament light source(s) are used to produce the principal passing beam.** It is possible to use several **filament** light sources **or LED module(s)** for each individual driving beam."

Paragraph 8., the reference to footnote 14/ and footnote 14/, renumber as footnote 13/.

Annex 1, item 9., amend to read:

"9. Brief description:

Category as described by the relevant marking: 3/

Number and category(ies) of filament lamp(s):

Number and specific identification code(s) of LED module(s):

Number and specific identification code(s) of electronic light source control gear(s):

**Total objective luminous flux as described in paragraph 5.8. exceeds 2,000 lumen:
yes/no 2/"**

Annex 2, insert a new figure 13., to read:

– **"Figure 13**

LED modules

MD E3 17325

The LED module bearing the light source module identification code shown above has been approved together with a headlamp initially approved in Italy (E3) under approval number 17325."

Annex 4,

Paragraph 1.1.1.1., amend to read:

- "1.1.1.1. (a) In the case where only one lighting function (driving or passing beam or front fog lamp) is to be approved, the corresponding filament **and/or LED module(s)** is **(are)** lit for the prescribed time, 2/
- (b) In the case of a headlamp with a passing beam and one or more driving beams or in case of a headlamp with a passing beam and a front fog lamp:
- (i) the headlamp shall be subjected to the following cycle until the time specified is reached:
15 minutes, **principal** passing-beam filament **or principal passing beam LED module(s)** lit;
5 minutes, all filaments **and/or LED module(s)** lit.
- (ii) if the applicant declares that the headlamp is to be used with only the passing beam lit or only the driving beam(s) lit 3/ at a time, the test shall be carried out in accordance with this condition, activating ^{2/} successively the passing beam half of the time and the driving beam(s) (simultaneously) for half the time specified in paragraph 1.1. above.
- (c) in the case of a headlamp with a front fog lamp and one or more driving beams:
- (i) the headlamp shall be subjected to the following cycle until the time specified is reached:
15 minutes, front fog lamp lit;
5 minutes, all filaments **and/or all LED modules** lit.

- (ii) if the applicant declares that the headlamp is to be used with only the front fog lamp lit or only the driving beam(s) lit ^{3/} at a time, the test shall be carried out in accordance with this condition, activating ^{2/} successively the front fog lamp half of the time and the driving beam(s) (simultaneously) for half the time specified in paragraph 1.1. above.
- (d) In the case of headlamp with a passing beam, one or more driving beams and a front fog lamp:
 - (i) the headlamp shall be subjected to the following cycle until the time specified is reached:
15 minutes, **principal** passing-beam filament **or principal passing beam LED module(s)** lit;
5 minutes, all filaments **and/or all LED modules** lit.
 - (ii) if the applicant declares that the headlamp is to be used with only the passing beam lit or only the driving beam(s) ^{3/} lit at a time, the test shall be carried out in accordance with this condition, activating ^{2/} successively the passing beam half of the time and the driving beam(s) for half the time specified in paragraph 1.1. above, while the front fog lamp is subjected to a cycle of 15 minutes off and 5 minutes lit for half of the time and during the operation of the driving beam;
 - (iii) if the applicant declares that the headlamp is to be used with only the passing beam lit or only the front fog lamp ^{3/} lit at a time, the test shall be carried out in accordance with this condition, activating ^{2/} successively the passing beam half of the time and the front fog lamp for half of the time specified in paragraph 1.1. above, while the driving beam(s) is(are) subjected to a cycle of 15 minutes off and 5 minutes lit for half of the time and during the operation of the passing beam;
 - (iv) if the applicant declares that the headlamp is to be used with only the passing beam lit or only the driving beam(s) ^{3/} lit or only the front fog lamp ^{3/} lit at a time, the test shall be carried out in accordance with this condition, activating ^{2/} successively the passing beam one third of the time, the driving beam(s) one third of the time and the front fog lamp for one third of the time specified in paragraph 1.1. above.
- (e) In the case of a passing beam designed to provide bend lighting with the addition of a **filament** light source **and/or one or more LED module(s)**, this light source **and/or LED module(s)** shall be switched on for one minute, and switched off for nine minutes during the activation of the passing beam only (see Annex 4 – Appendix 1)."

Paragraph 1.1.1.1., footnote 3/, amend to read:

"^{3/} Should two or more lamp filaments **and/or LED module(s)** be simultaneously lit when headlamp flashing is used, this shall not be considered as being normal use of the filaments **and/or LED module(s)**."

Paragraph 1.1.1.2., amend to read:

"1.1.1.2. Test voltage

For LED module(s) the test conditions set out in paragraph 6.1.4. of this Regulation shall apply.

For filament lamps according to Regulation No. 37 the voltage shall be adjusted so as to supply 90 per cent of the maximum wattage specified in Regulation No. 37 for the filament lamp(s) used.

The applied wattage shall in all cases comply with the corresponding value of a filament lamp of 12 V rated voltage, except if the applicant for approval specifies that the headlamp may be used at a different voltage. In the latter case the test shall be carried out with the filament lamp whose wattage is the highest that can be used."

Paragraph 1.2.1.3., amend to read:

"1.2.1.3. Measuring equipment

The measuring equipment shall be equivalent to that used during headlamp approval tests. A standard (étalon) filament lamp **and/or the LED module(s) as submitted with the headlamp** shall be used for the photometric verification."

Paragraph 2.1., amend to read:

"2.1. Test

The test shall be carried out in a dry and still atmosphere at an ambient temperature of $23\text{ °C} \pm 5\text{ °C}$.

Using a mass production filament lamp **or the LED module(s) as submitted with the headlamp**, which has (have) been aged for at least one hour, the headlamp shall be operated on **the principal** passing beam "

Annex 4 - Appendix 1, amend to read:

"Annex 4 - Appendix 1

OVERVIEW OF OPERATIONAL PERIODS CONCERNING TEST FOR STABILITY OF
 PHOTOMETRIC PERFORMANCE

Abbreviations:	P:	passing beam lamp
	D:	driving beam lamp (D ₁ + D ₂ means two driving beams)
	F:	front fog lamp
	— — — —	means a cycle of 15 minutes off and 5 minutes lit
	means a cycle of 9 minutes off and 1 minute lit

All following grouped headlamps and front fog lamps together with the added marking symbols are given as examples and are not exhaustive.

1. P or D or F (HC or HR or B)

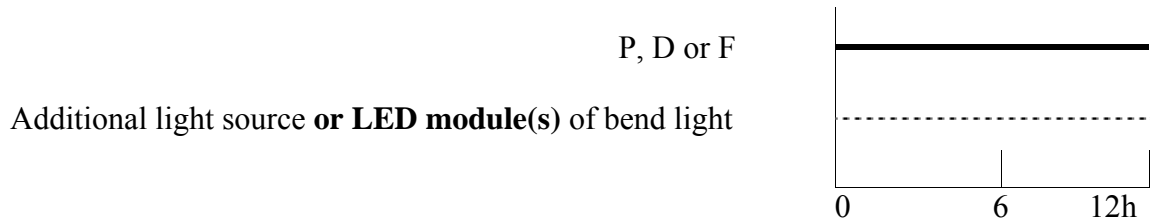

2. P+F (HC B) or P+D (HCR)

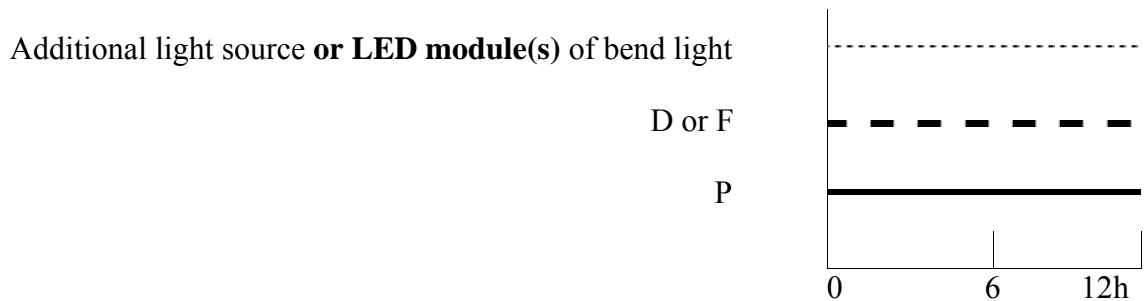

3. P+F (HC B/) or HC/B or P+D (HC/R)

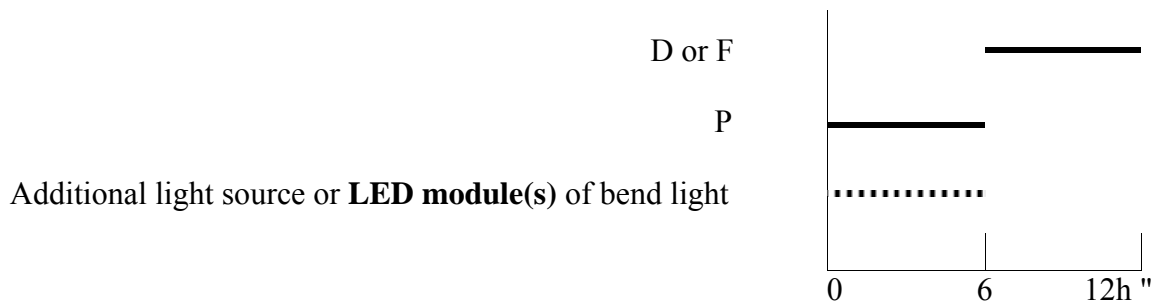

Annex 5,

Paragraph 1.2., amend to read:

"1.2. With respect to photometric performances, the conformity of mass-produced headlamps shall not be contested if, when testing photometric performances of any headlamp chosen at random and equipped with a standard (étalon) filament lamp **and/or LED module(s), as present in the lamp:**"

Paragraph 1.2.4., amend to read:

"1.2.4. **If in the case of a lamp equipped with a replaceable filament light source** the results of the tests described above do not meet the requirements, tests shall be repeated using another standard (étalon) filament lamp."

Annex 6,

Paragraph 2.1.2.1., amend to read:

"2.1.2.1. Method

Photometric measurements shall be carried out on the samples before and after the test.

These measurements shall be made using a standard (étalon) lamp **and/or LED module(s), as present in the headlamp,** at the following points:

B 50 L and 50 R for "

Insert a new paragraph 2.2.4., to read:

"**2.2.4. Resistance to light source radiations**

The following test shall be done:

Flat samples of each light transmitting plastic component of the headlamp are exposed to the light of the LED module(s). The parameters such as angles and distances of these samples shall be the same as in the headlamp. These samples shall have the same colour and surface treatment, if any, as the parts of the headlamp.

After 1,500 hours of continuous operation, the colorimetric specifications of the transmitted light must be met, and the surfaces of the samples shall be free of cracks, scratches, scalings or deformation."

Annex 6 - Appendix 1, Part A, amend to read:

"Annex 6 - Appendix 1

CHRONOLOGICAL ORDER OF APPROVAL TESTS

A. Tests on plastic materials (lenses or samples of material supplied pursuant to paragraph 2.2.4. of this Regulation).

Samples	Lenses or samples of material										Lenses			
	1	2	3	4	5	6	7	8	9	10	11	12	13	14
1.1. Limited photometry (A.6, para. 2.1.2.)											X	X	X	
1.1.1. Temperature change (A.6, para. 2.1.1.)											X	X	X	
1.2. Limited photometry (A.6, para. 2.1.2.)											X	X	X	
1.2.1. Transmission measurement	X	X	X	X	X	X	X	X	X					
1.2.2. Diffusion measurement	X	X	X				X	X	X					
1.3. Atmospheric agents (A.6, para. 2.2.1.)	X	X	X											
1.3.1. Transmission measurement	X	X	X											
1.4. Chemical agents (A.6, para.2.2.2.)	X	X	X											
1.4.1. Diffusion measurements	X	X	X											
1.5. Detergents (A.6, para. 2.3.1.)				X	X	X								
1.6. Hydrocarbons (A.6, para. 2.3.2.)				X	X	X								
1.6.1. Transmission measurement				X	X	X								
1.7. Deterioration (A.6, para. 2.4.1.)							X	X	X					
1.7.1. Transmission measurement							X	X	X					
1.7.2. Diffusion measurement							X	X	X					
1.8. Adherence (A.6, para. 2.5.)														X
1.9. Resistance to light source radiations (A.6, para. 2.2.4.)										X				

Annex 7,

Paragraph 1.2., amend to read:

"1.2. With respect to photometric performances, the conformity of mass-produced headlamps shall not be contested if, when testing photometric performances of any headlamp chosen at random and equipped with a standard filament lamp **and/or LED module(s) present in the headlamp:**"

Paragraph 1.2.4., amend to read:

"1.2.4. If the results of the tests described above do not meet the requirements, tests shall be repeated using another standard filament lamp **and/or LED module(s) present in the headlamp.**"

Insert new Annexes 9 and 10, to read:

Annex 9

REQUIREMENTS FOR LED MODULES AND HEADLAMPS INCLUDING LED MODULES

1. GENERAL SPECIFICATIONS

1.1. Each LED module sample submitted shall conform to the relevant specifications of this Regulation when tested with the supplied electronic light source control-gear(s), if any.

1.2. LED module(s) shall be so designed as to be and to remain in good working order when in normal use. They shall moreover exhibit no fault in design or manufacture. A LED module shall be considered to have failed if any one of its LEDs has failed.

1.3. LED module(s) shall be tamperproof.

1.4. The design of removable LED module(s) shall be such that:

1.4.1. when the LED module is removed and replaced by another module provided by the applicant and bearing the same light source module identification code, the photometric specifications of the headlamp shall be met;

1.4.2. LED modules with different light source module identification codes within the same lamp housing, shall not be interchangeable.

2. MANUFACTURE

2.1. The LED(s) on the LED module shall be equipped with suitable fixation elements.

2.2. The fixation elements shall be strong and firmly secured to the LED(s) and the LED module.

3. TEST CONDITIONS

3.1. Application

3.1.1. All samples shall be tested as specified in paragraph 4. below.

3.1.2. The kind of light sources on a LED MODULE shall be light-emitting diodes (LED) as defined in Regulation No. 48 paragraph 2.7.1. in particular with regard to the element of visible radiation. Other kinds of light sources are not permitted.

3.2. Operating conditions

3.2.1. LED module operating conditions

All samples shall be tested under the conditions as specified in paragraphs 6.1.4. and 6.1.5. of this Regulation. If not specified differently in this annex LED modules shall be tested inside the headlamp as submitted by the manufacturer.

3.2.2. Ambient temperature

For the measurement of electrical and photometric characteristics, the headlamp shall be operated in dry and still atmosphere at an ambient temperature of $23\text{ }^{\circ}\text{C} \pm 5\text{ }^{\circ}\text{C}$.

3.3. Ageing

Upon the request of the applicant the LED module shall be operated for 15 h and cooled down to ambient temperature before starting the tests as specified in this Regulation.

4. SPECIFIC SPECIFICATIONS AND TESTS

4.1. Colour rendering

4.1.1. Red content

In addition to measurements as described in paragraph 7. of this Regulation:

The minimum red content of the light of a LED module or headlamp incorporating LED module(s) tested at 50 V shall be such that:

$$k_{\text{red}} = \frac{\int_{\lambda=610 \text{ nm}}^{780 \text{ nm}} E_e(\lambda) V(\lambda) d\lambda}{\int_{\lambda=380 \text{ nm}}^{780 \text{ nm}} E_e(\lambda) V(\lambda) d\lambda} \geq 0.05$$

where:

$E_e(\lambda)$ (unit: W) is the spectral distribution of the irradiance;
 $V(\lambda)$ (unit: 1) is the spectral luminous efficiency;
 (λ) (unit: nm) is the wavelength.

This value shall be calculated using intervals of one nanometre.

4.2. UV-radiation

The UV-radiation of a low-UV-type LED module shall be such that:

$$k_{\text{UV}} = \frac{\int_{\lambda=250 \text{ nm}}^{400 \text{ nm}} E_e(\lambda) S(\lambda) d\lambda}{k_m \int_{\lambda=380 \text{ nm}}^{780 \text{ nm}} E_e(\lambda) V(\lambda) d\lambda} \leq 10^{-5} \text{ W / lm}$$

where:

$S(\lambda)$ (unit: 1) is the spectral weighting function;
 $k_m = 683 \text{ lm/W}$ is the maximum value of the luminous efficacy of radiation.

(For definitions of the other symbols see paragraph 4.1.1. above).

This value shall be calculated using intervals of one nanometer. The UV-radiation shall be weighted according to the values as indicated in the Table UV below:

λ	$S(\lambda)$	λ	$S(\lambda)$	λ	$S(\lambda)$
250	0.430	305	0.060	355	0.000 16
255	0.520	310	0.015	360	0.000 13
260	0.650	315	0.003	365	0.000 11
265	0.810	320	0.001	370	0.000 09
270	1.000	325	0.000 50	375	0.000 077
275	0.960	330	0.000 41	380	0.000 064
280	0.880	335	0.000 34	385	0.000 530
285	0.770	340	0.000 28	390	0.000 044
290	0.640	345	0.000 24	395	0.000 036
295	0.540	350	0.000 20	400	0.000 030
300	0.300				

Table UV: Values according to "IRPA/INIRC Guidelines on limits of exposure to ultraviolet radiation". Wavelengths (in nanometres) chosen are representative; other values should be interpolated.

4.3. Temperature stability

4.3.1. Illuminance

4.3.1.1. A photometric measurement of the headlamp shall be made after 1 minute of operation for the specific function at the test point specified below. For these measurements, the aim can be approximate but must be maintained for before and after ratio measurements.

Test points to be measured:

Passing beam 50 V

Driving beam H – V

4.3.1.2. The lamp shall continue operation until photometric stability has occurred. The moment at which the photometry is stable is defined as the point in time at which the variation of the photometric value is less than 3 per cent within any 15 minute period. After stability has occurred, aim for complete photometry shall be performed in accordance with requirements of specific device. Photometer the lamp at all test points required for the specific device.

4.3.1.3. Calculate the ratio between the photometric test point value determined in paragraph 4.3.1.1. and the point value determined in paragraph 4.3.1.2.

4.3.1.4. Once stability of photometry has been achieved, apply the ratio calculated above to each of the remainder of the test points to create a new photometric

table that describes the complete photometry based on one minute of operation.

- 4.3.1.5. The illuminance values, measured after one minute and after photometric stability has occurred, shall comply with the minimum and maximum requirements.**

4.3.2. Colour

The colour of the light emitted measured after one minute and measured after photometric stability has been obtained, as described in paragraph 4.3.1.2. of this annex, shall both be within the required colour boundaries.

- 5. The measurement of the objective luminous flux of LED module(s) producing the principal passing beam shall be carried out as follows:**

- 5.1. The LED module(s) shall be in the configuration as described in the technical specification as defined in paragraph 2.2.2. of this Regulation. Optical elements (secondary optics) shall be removed by the Technical Service at the request of the applicant by the use of tools. This procedure and the conditions during the measurements as described below shall be described in the test report.**

- 5.2. Three LED modules of each type shall be submitted by the applicant with the light source control gear, if applicable, and sufficient instructions.**

Suitable thermal management (e.g. heat sink) may be provided, to simulate similar thermal conditions as in the corresponding headlamp application.

Before the test each LED module shall be aged at least for seventy-two hours under the same conditions as in the corresponding headlamp application.

In the case of use of an integrating sphere, the sphere shall have a minimum diameter of one meter, and at least ten times the maximum dimension of the LED module, whichever is the largest. The flux measurements can also be performed by integration using a goniophotometer. The prescriptions in the CIE – Publication 84 – 1989, regarding the room temperature, positioning, etc., shall be taken into consideration.

The LED module shall be burned in for approximately one hour in the closed sphere or goniophotometer.

The flux shall be measured after stability has occurred, as explained in paragraph 4.3.1.2. of Annex 9 of this Regulation.

The average of the measurements of the three samples of each type of LED module shall be deemed to be its objective luminous flux.

Annex 10

**A GENERAL ILLUSTRATION FOR PRINCIPAL PASSING BEAM AND BEAM
CONTRIBUTORS AND CORRELATED LIGHT SOURCE OPTIONS**

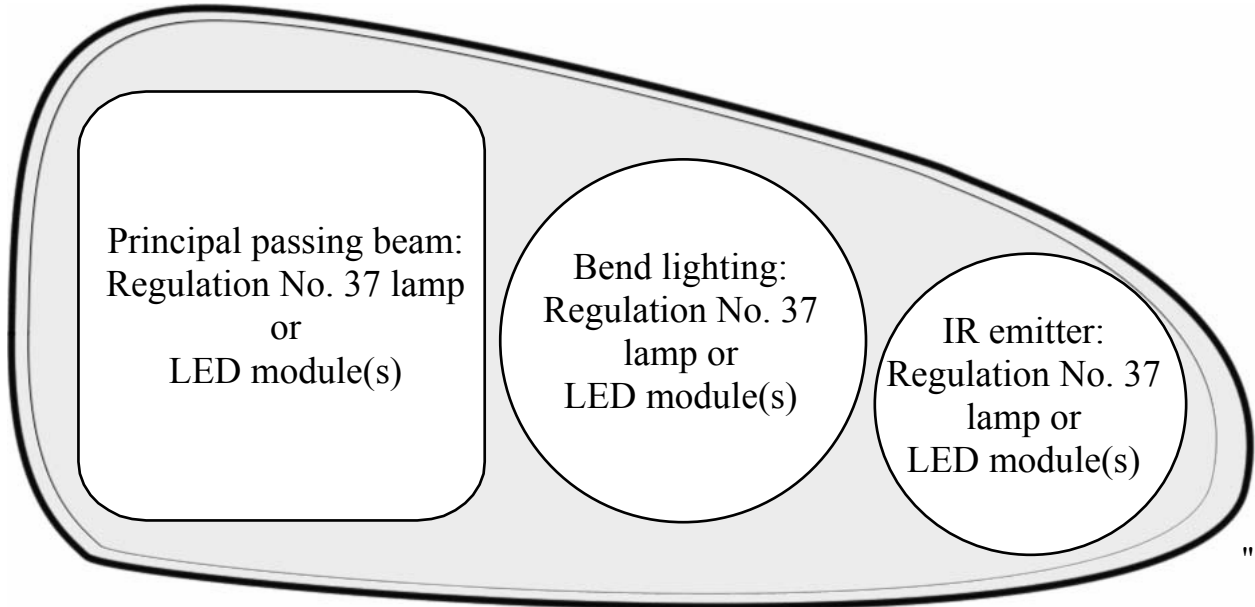

COMPILATION NOTES

This compilation of Vehicle Standard (Australian Design Rule 46/00 – Headlamps) 2006 includes all the instruments set out in the Table of Instruments. The Table of Amendments provides a history of clauses that have been amended, inserted or deleted.

Table of Instruments

Name of Instrument	Registration Date	Commencement Date
Vehicle Standard (Australian Design Rules 46/00 – Headlamps) 2006	21/07/2006	22/07/2006
Vehicle Standard (Australian Design Rules 46/00 – Headlamps) 2006 Amendment 1	23/07/2007	24/07/2007
Vehicle Standard (Australian Design Rules 46/00 – Headlamps) 2006 Amendment 2	23/07/2007	24/07/2007

Table of Amendments

Clause affected	How affected	Amending instrument
3.1	am	Vehicle Standard (Australian Design Rules 46/00 – Headlamps) 2006 Amendment 1
4.1	am	Vehicle Standard (Australian Design Rules 46/00 – Headlamps) 2006 Amendment 1
4.2	ad	Vehicle Standard (Australian Design Rules 46/00 – Headlamps) 2006 Amendment 2
5.1	am	Vehicle Standard (Australian Design Rules 46/00 – Headlamps) 2006 Amendment 1
5.6	ad	Vehicle Standard (Australian Design Rules 46/00 – Headlamps) 2006 Amendment 1
5.7	ad	Vehicle Standard (Australian Design Rules 46/00 – Headlamps) 2006 Amendment 1
Appendix F	ad	Vehicle Standard (Australian Design Rules 46/00 – Headlamps) 2006 Amendment 1
Appendix G	ad	Vehicle Standard (Australian Design Rules 46/00 – Headlamps) 2006 Amendment 1
Appendix H	ad	Vehicle Standard (Australian Design Rules 46/00 – Headlamps) 2006 Amendment 2

ad = added or inserted

am = amended

del = deleted or removed

rr = removed and replaced

→ = clause renumbered. This takes the format of old no. → new no.